

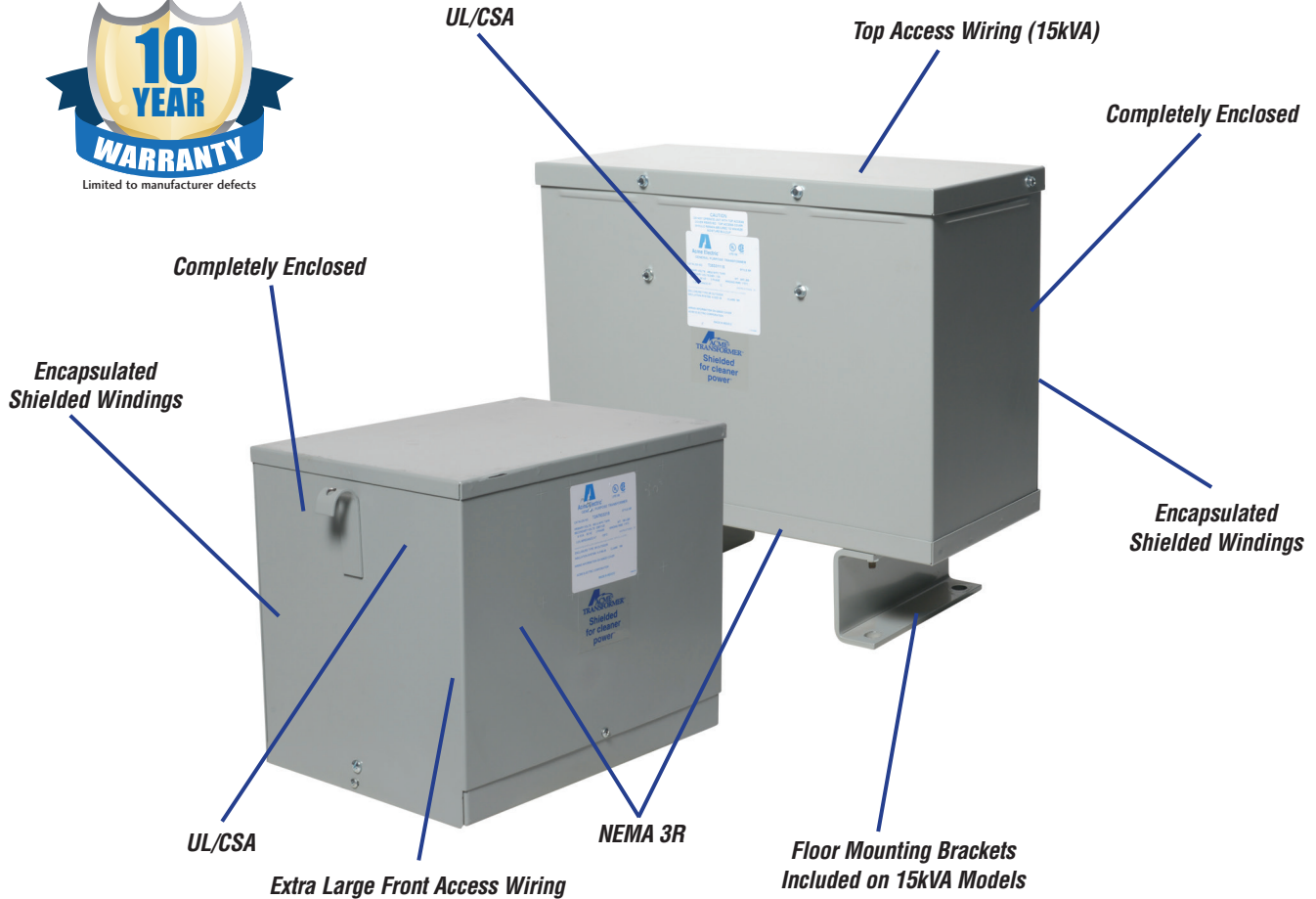

Dry-type Encapsulated 3-Phase Distribution Transformers



Applications

- Excellent for dust or lint laden atmosphere
- Suitable for indoor/outdoor Service

Agency Approvals

- UL Listed File E79947 (Style SR)
- CSA File No. LR7357 (Type SR)
- RoHS

Features

- UL listed, CSA certified and UL type 3R enclosure meets or exceeds all listing criteria including NEMA, ANSI and OSHA standards.
- UL Class 180°C insulation system. 115°C rise.
- Extra large front access wiring compartment through 9kVA; top access for easier installation and cooler case temperatures for 15kVA models.
- Completely enclosed — suitable for indoor/outdoor service. Consult selection charts for details. Excellent for dust or lint laden atmosphere.
- Encapsulated — electrical grade silica and resin compound completely encloses the core and coil. Encapsulation seals out all moisture and air, eliminating corrosion and insulation deterioration.
- High efficiency and excellent regulation.
- Sound levels below NEMA standards.

- Keyhole mounting slots permit installation of mounting bolts prior to hanging transformer and are accessible from the front. Lifting ears for easy installation (up to 9kVA).
- Wiring connections can be made outside of wiring compartment due to the use of flexible leads.
- 3-9 kVA provided with dual size knockouts in sides and bottom of wiring compartment.
- Termination — copper lead wire.
- Electrostatic shielding provided on all 60Hz isolation transformers.



Acme Transformer Selection

Three Phase Loads

1. Determine electrical load

- A. Voltage required by load.
- B. Amperes or kVA required by load.
- C. Frequency in Hz (cycles per second).
- D. Verify load is designed to operate on 3-phase.

All the above information is standard data normally obtained from equipment nameplates or instruction manuals.

2. Determine supply voltage

- A. Voltage of supply (source).
- B. Frequency in Hz (cycles per second).

The frequency of the line supply and electrical load must be the same. A 3-phase transformer is selected which is designed to operate at this frequency having a primary (input) equal to the supply voltage and a secondary (output) equal to the voltage required by the load.

3. If the load nameplate expresses a rating in kVA, a transformer can be directly selected from the charts. Choose from the group of transformers with primary and secondary voltages matching that which you have just determined.

- A. Select a transformer with a standard kVA capacity equal to or greater than that needed to operate the load.
- B. Primary taps are available on most models to compensate for line voltage variations.
- C. When load ratings are given only in amperes, tables 1, 2 and 3 or the following formulas may be used to determine proper kVA size for the required transformer.

(1) To determine **3-phase** kVA when volts and amperes are known:

$$\text{3-Phase kVA} = \frac{\text{Volts} \times \text{Amps} \times 1.73}{1000}$$

(2) To determine **Amperes** when kVA and volts are known:

$$\text{Amps} = \frac{\text{3-Phase kVA} \times 1000}{\text{Volts} \times 1.73}$$

Three Phase Example

Question: Select a transformer to fulfill the following conditions. Load is a 3-phase induction motor, 25hp @ 240V, 60Hz and a heater load of 4kW @ 240V single phase. The supply voltage is 480Y/277, 3-phase, 4 wire.

Answer: Compute the kVA required. Motor—From table 2 the current is 68A.

$$\frac{240\text{V} \times 68\text{A} \times 1.73}{1000} = 28.2 \text{ kVA}$$

(The kVA can also be obtained from Table 3)

Heater — 4kVA

A 3-phase transformer must be selected so that any one phase is not overloaded. Each phase should have the additional 4kVA rating required by the heater even though the heater will operate on one phase only. So, the transformer should have a minimum kVA rating of 28.2 + 4 + 4 + 4 or 40.2 kVA. Refer to the appropriate selection chart. A 480 delta primary — 240 delta secondary transformer may be used on a 4 wire, 480Y/277 volt supply. The fourth wire (neutral) is not connected to the transformer. To not overload the transformer, a 45kVA transformer should be selected.

Note: Any two wires of the 240V, 3-phase developed by the secondary of the transformer may be used to supply the heater.

Any 2 wires of a 3-phase system is single phase.

Acme Transformer Selection

Table 1 - Full Load Current (A) Three-phase Circuits						
kVA	208V	240V	380V	440V	480V	600V
3	8.3	7.2	4.6	3.9	3.6	2.9
4.5	12.5	10.8	6.8	5.9	5.4	4.3
6	16.6	14.4	9.1	7.8	7.2	5.8
9	25	21.6	13.7	11.8	10.8	8.6
15	41	36	22.8	19.6	18.0	14.4

Table 2 - Full Load Current (A) Single-phase Circuits		
kVA	120V	277V
3	25	10.8
6	50	21.6
9	75	32.5
15	125	54

Table 3 - Full Load Current (A) 3-Phase AC Motors ¹					
hp	208V	230V	460V	575V	Minimum Transformer kVA
1/2	2.2	2.0	1.0	0.8	0.9
3/4	3.1	2.8	1.4	1.1	1.2
1	4.0	3.6	1.8	1.4	1.5
2	7.5	6.8	3.4	2.7	2.7
3	10.7	9.6	4.8	3.9	3.8
5	16.7	15.2	7.6	6.1	6.3
10	31	28	14	11	11.2
15	46	42	21	17	16.6
20	59	54	27	22	21.6
25	75	68	34	27	26.6
30	88	80	40	32	32.4
40	114	104	52	41	43.2
50	143	130	65	52	52
60	170	154	77	62	64
75	213	192	96	77	80
100	273	248	124	99	103
125	342	312	156	125	130
150	396	360	180	144	150
200	528	480	240	192	200

¹When motor service factor is greater than 1, increase full load amps proportionally.

Example: If service factor is 1.15, increase above amp values by 15%.

$$\text{3-Phase kVA} = \frac{\text{Volts} \times \text{Amps} \times 1.73}{1000}$$

Note: If motors are started more than once per hour, increase minimum transformer kVA by 20%.

Acme Encapsulated 3-Phase Transformers



Features

- Fully encapsulated core and coil
- UL Type 3R epoxy encapsulated
- Grounding studs for use with non-metallic conduit
- Copper lead wire terminations
- Electrostatic shield standard

General Specifications

- Temperature range: -20°C [-4°F] to average ambient temperature 30°C [86°F], not to exceed 40°C [104°F] without derating the transformer.
- Maximum temperature rise: 115°C [239°F]
- BNFC (below normal full capacity) taps: 2
- Taps 5% per step
- Frequency: 60Hz
- For proper overcurrent protection, refer to NEC 450.3, 2014

Approvals

- UL 506
- UL File E79947 (Style SR)
- CSA Standard C22.2 No. 47
- CSA file LR7357-32 (Type SR)



To obtain the most current agency approval information, see the Agency Approval Checklist section on the specific part number's web page.

Acme Encapsulated 3-Phase Transformers*										
Part Number	Price	kVa Rating	Primary Volts	Secondary Volts	Impedance %Z (Ω)	Total Heat Dissipation (W)	Mounting Type	Weight lb [kg]	Wiring Diagram	Drawing #
T2A533081S ¹		3.0	480 Delta	208Y/120	3.7	143.7	Wall Mount	75 [34.0]	A	1
T2A533091S ¹		6.0			2.42	257.76	Wall Mount	140 [63.5]		1
T2A533101S ¹		9.0			2.57	325.02	Wall Mount	180 [81.6]		1
T3533111S ¹	1.00	15.0			2.91	296.19	Floor Mount ³	250 [113.0]		2
T2A533281S ¹		3.0	480 Delta	240 Delta/120Tap ²	3.68	143.59	Wall Mount	75 [34.0]	B	1
T2A533291S ¹		6.0			2.64	245.77	Wall Mount	140 [63.5]		1
T2A533401S ¹		9.0			2.96	329.04	Wall Mount	180 [81.6]		1
T3533411S ¹	1.00	15.0			3.02	297.49	Floor Mount ³	250 [113.0]		2
T2A793301S		3.0	600 Delta	208Y/120	3.73	145.8	Wall Mount	75 [34.0]	C	1
T2A793311S		6.0			2.55	245.27	Wall Mount	140 [63.5]		1
T2A793321S	3.00	9.0			1.86	323.4	Wall Mount	180 [81.6]		1
T3793331S	2.00	15.0			2.5	296.63	Floor Mount ³	250 [113.0]		2
T2A795161S		3.0	600 Delta	480Y/277	3.91	146.29	Wall Mount	75 [34.0]	D	1
T2A795171S		6.0			2.65	244.14	Wall Mount	140 [63.5]		1
T2A795181S	3.00	9.0			2.69	166.74	Wall Mount	180 [81.6]		1
T3795191S	2.00	15.0			3.17	213	Floor Mount ³	250 [113.0]		2

* DOE 2016 exempt encapsulated unit.

¹ May be used on a 4-wire 480Y/277V supply.

² Provided with 120V lighting tap limited to 5% of nameplate kVA rating.

³ Wall mounting brackets are available for these sizes.

Wall Mounting Bracket		
Part Number	Price	Description
PL79911		Transformer wall mounting brackets for use with Acme 15kVA encapsulated 3-phase transformers. Package contains one (1) each left and right bracket. Cold rolled steel. Weight 13lb/5.9 kg.

Hardware not included. Important, check the weight of the unit and confirm that the wall and the fasteners (not supplied with the kit) can support the unit.

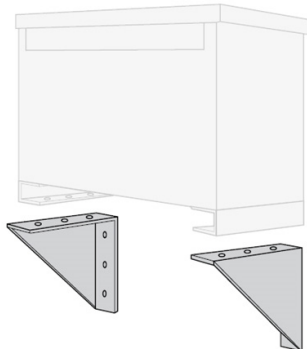

in [mm]

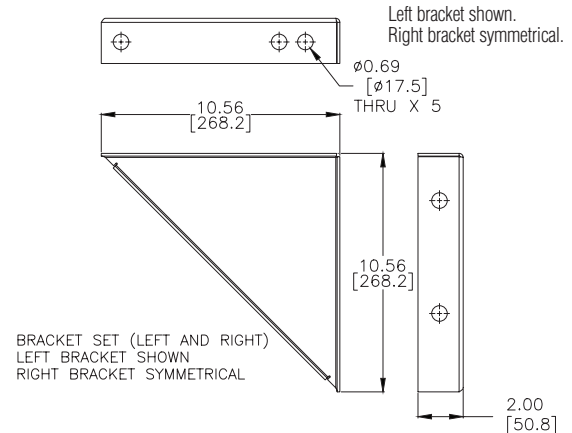

See our website: for complete engineering drawings

Acme Encapsulated 3-Phase Transformers

WIRING DIAGRAM A	Primary Volts	Connect Lines To	Inter-connect
	480	H1, H2, H3	1-H1, 1-H2, 1-H3
	456	H1, H2, H3	2-H1, 2-H2, 2-H3
	432	H1, H2, H3	3-H1, 3-H2, 3-H3
	Secondary Volts	Connect Lines To	Inter-connect
208	X1, X2, X3		
120 (1-phase)	X1, X0 X2, X0 X3, X0		
WIRING DIAGRAM B	Primary Volts	Connect Lines To	Inter-connect
	480	H1, H2, H3	1-H1, 1-H2, 1-H3
	456	H1, H2, H3	2-H1, 2-H2, 2-H3
	432	H1, H2, H3	3-H1, 3-H2, 3-H3
	Secondary Volts	Connect Lines To	Inter-connect
240	X1, X2, X3		
120	X1, X4 or X2, X4		
WIRING DIAGRAM C	Primary Volts	Connect Lines To	Inter-connect
	600	H1, H2, H3	1-H1, 1-H2, 1-H3
	570	H1, H2, H3	2-H1, 2-H2, 2-H3
	540	H1, H2, H3	3-H1, 3-H2, 3-H3
	Secondary Volts	Connect Lines To	Inter-connect
208	X1, X2, X3		
120 (1-phase)	X1, X0 X2, X0 X3, X0		
WIRING DIAGRAM D	Primary Volts	Connect Lines To	Inter-connect
	600	H1, H2, H3	1-H1, 1-H2, 1-H3
	570	H1, H2, H3	2-H1, 2-H2, 2-H3
	540	H1, H2, H3	3-H1, 3-H2, 3-H3
	Secondary Volts	Connect Lines To	Inter-connect
480	X1, X2, X3		
277 (1-phase)	X1, X0 X2, X0 X3, X0		



Termination Wire Size (AWG) – Lead Type Connections		
Part Number	HV	LV
T2A533081S	#14 CLP	#14 CLP
T2A533091S	#14 CLP	#12 CLP
T2A533101S	#14 CLP	#10 CLP
T3533111S	#14 CLP	#8 CLP
T2A533281S	#14 CLP	#14 CLP
T2A533291S	#14 CLP	#14 CLP
T2A533401S	#14 CLP	#14 CLP
T3533411S	#14 CLP	#10 CLP
T2A793301S	#14 CLP	#14 CLP
T2A793311S	#14 CLP	#12 CLP
T2A793321S	#14 CLP	#14 CLP
T3793331S	#14 CLP	#8 CLP
T2A795161S	#14 CLP	#14 CLP
T2A795171S	#14 CLP	#14 CLP
T2A795181S	#14 CLP	#14 CLP
T3795191S	#14 CLP	#14 CLP

CLP = Cross-linked Polyethylene (cable insulation material)

Acme Encapsulated 3-Phase Transformers

Dimensions

in [mm]

Drawing 1

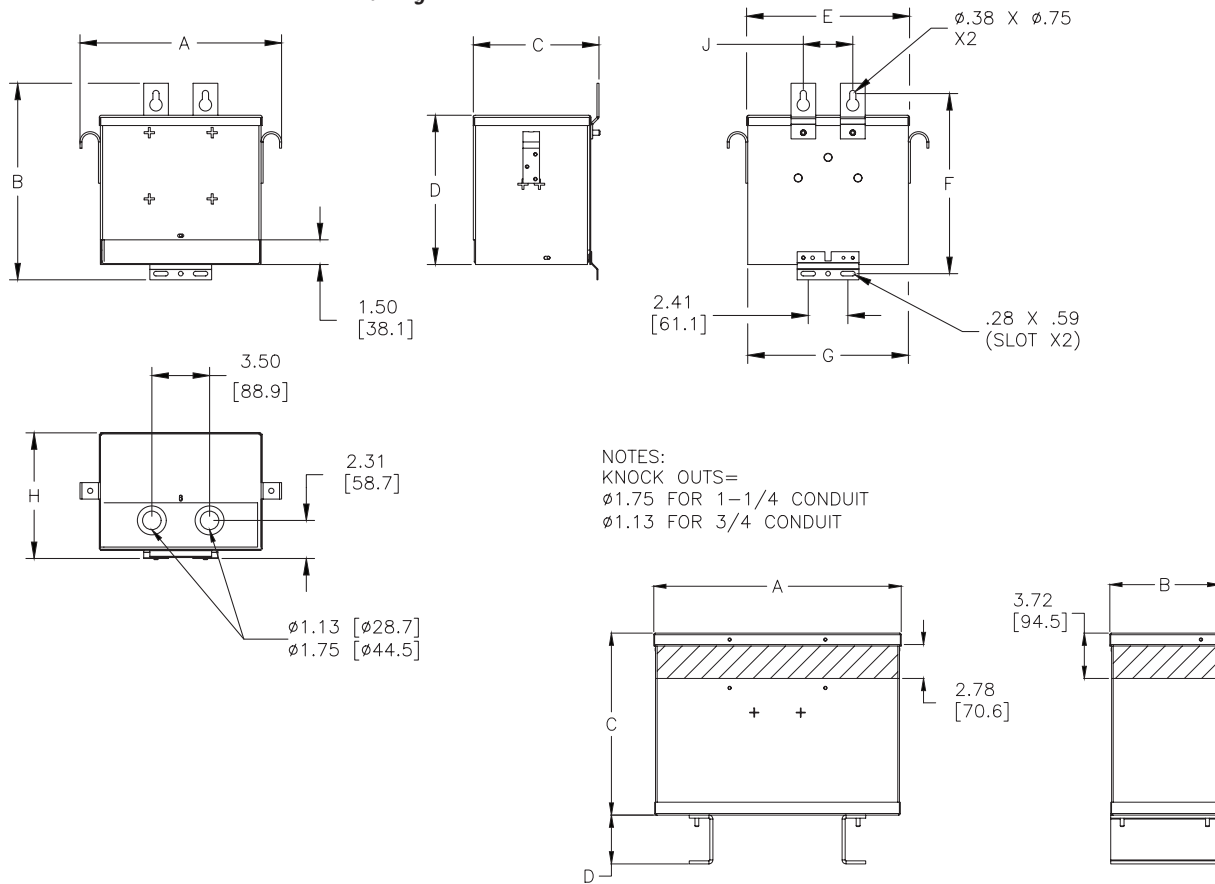

NOTES:
KNOCK OUTS=
Ø1.75 FOR 1-1/4 CONDUIT
Ø1.13 FOR 3/4 CONDUIT

Drawing 2

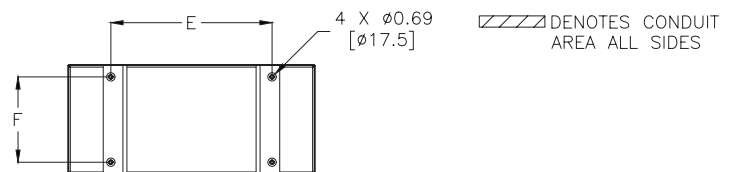

See our website: for complete engineering drawings

Acme Encapsulated Transformer Dimensions – in [mm]										
Part Number	Dwg	A	B	C	D	E	F	G	H	J
T2A533081S	1									
T2A533281S	1	12.23	11.93	7.13	9.06	9.88	10.93	9.75	7.63	3.63
T2A793301S	1	[310.6]	[303.0]	[181.1]	[230.1]	[251.0]	[277.6]	[247.7]	[193.8]	[92.2]
T2A795161S	1									
T2A533091S	1									
T2A533291S	1	14.03	12.84	8.48	9.97	11.68	11.84	11.55	8.98	3.63
T2A793311S	1	[356.4]	[326.1]	[215.4]	[253.2]	[296.7]	[300.7]	[293.4]	[228.1]	[92.2]
T2A795171S	1									
T2A533101S	1									
T2A533401S	1	17.63	15.57	11.18	12.70	15.28	14.57	15.15	11.63	3.63
T2A793321S	1	[447.8]	[395.5]	[284.0]	[322.6]	[388.1]	[370.1]	[384.8]	[295.4]	[92.2]
T2A795181S	1									
T3533111S	2									
T3533411S	2	20.29	9.02	14.93	4.00	13.22	7.00	-	-	-
T3795191S	2	[515.4]	[229.1]	[379.2]	[101.6]	[335.8]	[177.8]			
T3793331S	2									

Acme Transformers

Frequently Asked Questions

1. Can transformers be used in parallel?

Single phase transformers can be used in parallel only when their impedances and voltages are equal. If unequal voltages are used, a circulating current exists in the closed network between the two transformers, which will cause excess heating and result in a shorter life of the transformer. In addition, impedance values of each transformer must be within 7.5% of each other. For example: Transformer A has an impedance of 4%, transformer B, which is to be parallel to A, must have an impedance between the limits of 3.7% and 4.3%. When paralleling 3-phase transformers, the same precautions must be observed as listed above, plus the angular displacement and phasing between the two transformers must be identical.

2. Can Acme Transformers be reverse connected?

ACME dry-type distribution transformers can be reverse connected without a loss of kVA rating, but there are certain limitations. Transformers rated 3kVA and larger can be reverse connected without any adverse effects or loss in kVA capacity. The reason for this limitation in kVA size is, the turns ratio is the same as the voltage ratio. Example: A transformer with a 480V input, 240V output can have the output connected to a 240V source and thereby become the primary or input to the transformer, then the original 480V primary winding will become the output or 480V secondary. The transformer will not be damaged if used in a reverse connection; however, the output voltage will be lower than is indicated by the nameplate.

3. What is meant by regulation in a transformer?

Voltage regulation in transformers is the difference between the no load voltage and the full load voltage. This is usually expressed in terms of percentage. For example: A transformer delivers 100V at no load and the voltage drops to 95V at full load, the regulation would be 5%. ACME dry-type distribution transformers generally have regulation from 2% to 4%, depending on the size and the application for which they are used.

4. Why is impedance important?

It is used for determining the interrupting capacity of a circuit breaker or fuse employed to protect the primary of a transformer. Example: Determine a minimum circuit breaker trip rating and interrupting capacity for a 10kVA single phase transformer with 4% impedance, to be operated from a 480V 60Hz source.

Calculate as follows:

$$\text{Normal Full Load Current} = \frac{\text{Nameplate Volt Amps}}{\text{Line Volts}} = \frac{10,000\text{VA}}{480\text{V}} = 20.8 \text{ A}$$

$$\text{Maximum Short Circuit Amps} = \frac{\text{Full Load Amps}}{4\%} = \frac{20.8 \text{ A}}{4\%} = 520\text{A}$$

The breaker or fuse would have a minimum interrupting rating of 520A at 480V.

Example: Determine the interrupting capacity, in amperes, of a circuit breaker or fuse required for a 75kVA, 3-phase transformer, with a primary of 480V delta and secondary of 208Y/120 V. The transformer impedance (Z) = 5%. If the secondary is short circuited (faulted), the following capacities are required:

$$\text{Normal Full Load Current} = \frac{\text{Volt Amps}}{\sqrt{3} \times \text{Line Volts}} = \frac{75,000\text{VA}}{\sqrt{3} \times 480\text{V}} = 90\text{A}$$

$$\text{Maximum Short Circuit Amps} = \frac{\text{Full Load Amps}}{5\%} = \frac{90\text{A}}{5\%} = 1,800\text{A}$$

The breaker or fuse would have a minimum interrupting rating of 1,800 amps at 480 volts.

Note: The secondary voltage is not used in the calculation. The reason is the primary circuit of the transformer is the only winding being interrupted.

Acme Transformers

Frequently Asked Questions

5. Can 60Hz transformers be used at higher frequencies?

ACME transformers can be used at frequencies above 60Hz up to 400Hz with no limitations provided nameplate voltages are not exceeded. However, 60Hz transformers will have less voltage regulation at 400Hz than at 60Hz.

6. What color are ACME Dry-Type Transformers?

ASA 61 (NEMA) light gray is used on all enclosed transformers from 0.050 to 1000kVA.

7. How do you select a transformer to operate in an ambient higher than 40°C?

When the ambient exceeds 40°C use the following chart for de-rating standard transformers.

<i>Maximum Ambient Temperature</i>	<i>Maximum Percentage of Loading</i>
40°C (104°F)	100%
50°C (122°F)	92%
60°C (140°F)	84%

Instead of ordering custom built transformers to operate in ambients higher than 40°C, it is more economical to use a standard transformer of a larger kVA rating.