

3ACT/3ACTR Series 3-Phase AC Current Transducers



The 3ACT/3ACTR Series AC 3-Phase Current Transducers are designed for monitoring three-phase loads, motors, machines or buildings. The large triple-aperture fixed core design allows for a quick and easy installation. The transducer outputs are powered from an excitation voltage of 24 VAC or DC, isolated from the monitored circuit. Average responding and True RMS models are available with three outputs that are proportional to the AC current in each phase and a fourth output represents the average of the three. The transducer can be mounted on a back panel or a DIN rail using the integral mounting clips and is designed to accommodate wire sizes for loads up to 200 amps.

Applications

Monitor Large Machines

- Detect over or undercurrent conditions before they cause break downs or interlock one process with another.

Water Delivery and Treatment

- Detect open discharge lines.
- Sense clogged filters or blocked intake to pumps.
- Measure increased current to show failing bearings or pump impeller cavitation.

Generators

- Shed noncritical loads when demand reaches a set level.

Load Imbalance

- Monitor motor current draw which should be nearly equal in all three phases.

Features

- Average responding and True RMS models with analog 4-20mA output signals proportional to AC current
- Compatible with most automation and control systems.
- Three separate outputs represent the current in each phase. A fourth output produces a signal proportional to the average of the current in all three phases.
- Fixed core Case
- Current sensing ranges up to 200A
- Sensing windows provide ample space for single or multiple conductors per phase.
- Snap onto DIN rail using integral mounting clips or attach with screws to a panel for secure mounting.
- Five-year warranty



3ACT/3ACTR Series 3-Phase AC Current Transducers				
Part Number	Description	Pcs/Pkg	Wt (lb)	Price
3ACT030-42-24-F	AcuAMP AC 3-phase current transducer, fixed core, 0-10, 0-15, or 0-30A selectable sensing range, 4-20mA output.	1	1.0	
3ACT100-42-24-F	AcuAMP AC 3-phase current transducer, fixed core, 0-30, 0-50, or 0-100A selectable sensing range, 4-20mA output.	1	1.0	
3ACT200-42-24-F	AcuAMP AC 3-phase current transducer, fixed core, 0-100, 0-150, or 0-200A selectable sensing range, 4-20mA output.	1	1.0	
3ACTR030-42-24-F	AcuAMP AC 3-phase current transducer, fixed core, 0-10, 0-15, or 0-30A selectable sensing range, True RMS, 4-20mA output.	1	1.0	
3ACTR100-42-24-F	AcuAMP AC 3-phase current transducer, fixed core, 0-30, 0-50, or 0-100A selectable sensing range, True RMS, 4-20mA output.	1	1.0	
3ACTR200-42-24-F	AcuAMP AC 3-phase current transducer, fixed core, 0-100, 0-150, or 0-200A selectable sensing range, True RMS, 4-20mA output.	1	1.0	

Specifications	
Power Supply	24 VAC/DC (+/- 10%), Intended for use with a Class 2 source with the secondary fused to limit power to a maximum of 100 VA Note: Power Supply and output signal ARE NOT isolated. Do not connect the negative terminals to a common point.
Power Consumption	< 6.0 VA
Output Signals	4-20mA Four outputs, three proportional to the current in that phase, one an average of all three.
Output Limit	20.8 mA
Output Impedance	500Ω maximum
Accuracy	1.0% FS
Response Time	220ms (90% step change)
Frequency Range	3ACT: 50/60Hz, Average Responding 3ACTR: 30-100Hz, True RMS
Sensed Current Limit	1.1x range continuous 3x range for 6 seconds 6x range for 1 second
Isolation Voltage	UL tested to 1240VAC
Sensing Apertures	0.86 in (21.8 mm) dia.
Case	UL 94V-0 Flammability rated thermoplastic
Environmental	-Temp -4 to 122°F (-20 to 50°C) -Humidity 0-95% RH, Non-condensing -Pollution degree 2 -Altitude 2000 meters
Certifications	cULus listed E197592 CE

ACUAMP® 3ACT Series AC Current Transducers

Wiring

3ACT/3ACTR Series

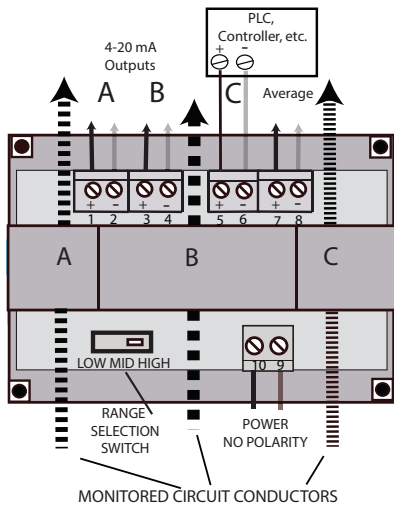

Note: Power supply and output signal ARE NOT isolated. Do not connect the negative terminals to a common point.

Top View

Dimensions

Inches [mm]

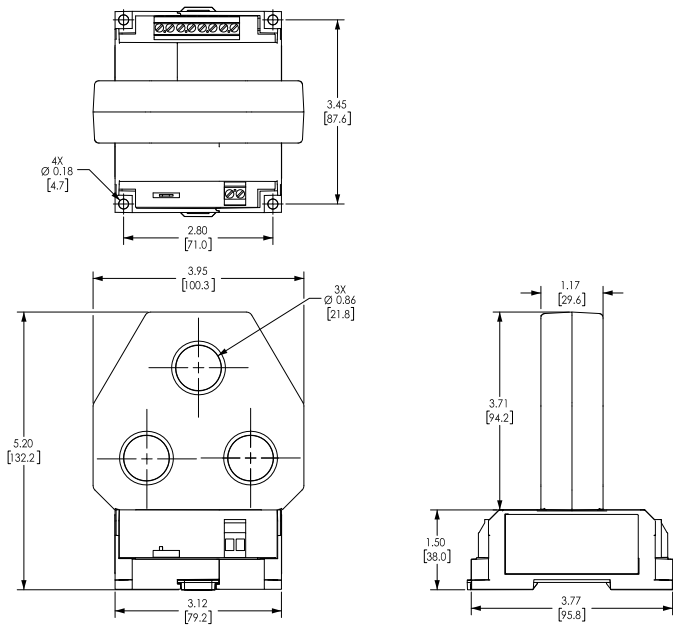

Submersible Pump Application

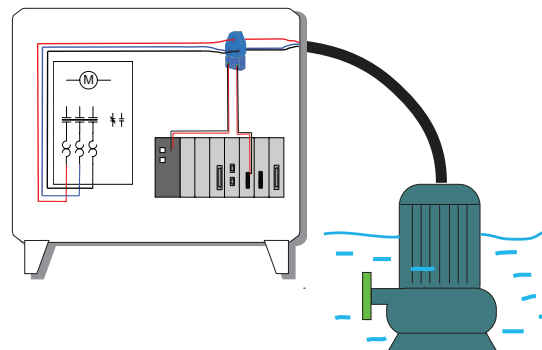

AC Current Switches, Transducers and Indicators

Overview

The AcuAMP series of AC current sensors is a family of high-performance current sensors offering outstanding features, flexibility, and durability at an incredible Price. Choose from a wide selection of current transducers, switches and indicators, all designed in a rugged industry-standard feed-through package, including both fixed core and split core models.

AcuAMP current sensors are available with

a broad selection of input sensing ranges for maximum flexibility across many current ratings. The current transducer output choices include 4-20 mA, 24VDC loop-powered, and 0 to 10 volt self-powered analog outputs. The Current Switch outputs include isolated solid state switches available in Normally Open and Normally Closed configurations or SPDT relays.

Models with output time delay are also offered in the Current Switch series. The

ACL1 Current Indicator senses AC current ranging from 0.5 to 100A and requires no power for the indicating LED.

These current sensors can be mounted in a panel or attached to the monitored conductor with a wire tie. Use the Selection Guide below to find the best sensor for your requirements.



AcuAMP AC Current Transducer Selection Guide

Specifications	Single-Phase Transducer	Single-Phase Transducer (True RMS)	3-Phase Transducer	3-Phase Transducer (True RMS)
Series	ACT	ACTR	3ACT	3ACTR
Sensing Range	Selectable: ACT005: 0 to 2A 0 to 5A ACT050: 0 to 10A 0 to 20A 0 to 50A ACT200: 0 to 100A 0 to 150A 0 to 200A ACT750: 0 to 375A 0 to 500A 0 to 750A ACT2000: 0 to 1000A 0 to 1333A 0 to 2000A Fixed range: ACT400 0 to 400A ACT600 0 to 600A ACT800 0 to 800A ACT1200 0 to 1200A	Selectable: ACTR005: 0 to 2A 0 to 5A ACTR050: 0 to 10A 0 to 20A 0 to 50A ACTR200: 0 to 100A 0 to 150A 0 to 200A ACTR750: 0 to 375A 0 to 500A 0 to 750A ACTR2000: 0 to 1000A 0 to 1333A 0 to 2000A Fixed range: ACTR400: 0 to 400A ACTR500: 0 to 500A ACTR600: 0 to 600A ACTR800: 0 to 800A ACTR1000: 0 to 1000A ACTR1200: 0 to 1200A ACTR2000: 0 to 2000A	Selectable: 3ACT030: 0 to 10A 0 to 15A 0 to 30A 3ACT100: 0 to 30A 0 to 50A 0 to 100A 3ACT200: 0 to 100A 0 to 150A 0 to 200A	Selectable: 3ACTR030: 0 to 10A 0 to 15A 0 to 30A 3ACTR100: 0 to 30A 0 to 50A 0 to 100A 3ACTR200: 0 to 100A 0 to 150A 0 to 200A
Output	-10 models: 0–10 VDC, self-powered -42L models: 4–20 mA, loop-powered	4–20 mA, loop-powered True RMS	4 -20 mA, loop-powered	4–20 mA, loop-powered True RMS
Frequency Range	-10 models: 50 to 60 Hz -42L models up to 200A: 20 to 100 Hz -42L models 400, 600, 800, 1200A: 50 to 60 Hz sinusoidal waveforms only	20 to 400 Hz; (40 to 400 Hz flexible split core models) sinusoidal and non-sinusoidal waveforms	50 to 60 Hz sinusoidal waveforms only	30 to 100 Hz sinusoidal and non-sinusoidal waveforms
Sensing Aperture	ACT005, ACT050, ACT200: Fixed core: 0.75 in [19mm] dia. Split core: 0.85 in [21.6 mm] sq. ACT750, ACT2000: Fixed core: 3.0 in [76.2 mm] dia. ACT400, ACT600, ACT800: Split core: 2.22 X 1.19 in [56.3 X 30.2 mm] ACT1200 Split core: 3.44 X 2.31 in [87.3 X 58.8 mm]	ACTR005, ACTR050, ACTR200: Fixed core: 0.75 in [19mm] dia. Split core: 0.85 in [21.6 mm] sq. ACTR750, ACTR2000: Fixed core: 3.0 in [76.2 mm] dia. ACTR500, ACTR1000, ACTR2000: Flexible split core: 4.5 in [114.3 mm] dia. ACTR400, ACTR600, ACTR800: Split core: 2.22 X 1.19 in [56.3 X 30.2 mm] ACTR1200 Split core: 3.44 X 2.31 in [87.3 X 58.8 mm]	3x - Fixed core: 0.86 in [21.8 mm] dia.	3x - Fixed core: 0.86 in [21.8 mm] dia.



AC Current Switches, Transducers and Indicators

AcuAMP AC Current Switch Selection Guide								
Specifications	AC Current Switches							
Series	ACSN100	ACSN250	ACS150	ACSL	ACS200	ACS050/ACS200	ACS035/ACS400	ACSX
Sensing Range	0 to 100A	0 to 250A	Fixed core: 1 to 150A Split core: 1.75 to 150A	0 to 50A	Jumper Selectable: Fixed core: 1 to 6A 6 to 40A 40 to 175A Split core: 1.75 to 6A 6 to 40A 40 to 200A	1 to 200A	2 to 400A	Jumper Selectable: Fixed core: 1.5 to 12A 12 to 55A 55 to 175A Split core: 2 to 12A 12 to 55A 55 to 200A
Setpoint (Trip Point)	Non-adjustable: 0.5 A	Non-adjustable: Fixed core: 0.75A Split core: 1.25A	Adjustable: Fixed core: 1-150 A (15-turn potentiometer) Split core: 1.75-150 A (4-turn potentiometer) Monitored load current required to adjust setpoint	Adjustable (3/4-turn potentiometer): ACSL010: 1-10A ACSL020: 2-20A ACSL050: 10-50A Monitored load current not required to adjust setpoint	Adjustable: (4-turn or 15-turn potentiometer) Fixed core: 1-175A Split core: 1.75-200A Monitored load current required to adjust setpoint	Adjustable: (Single turn potentiometer): ACS050: 1-50A ACS200: 4-200A	Adjustable: (3/4-turn potentiometer): ACS035: 2-35A ACS400: 25-400A	Adjustable: Fixed core: 1.5-175A (15-turn potentiometer) Split core: 2-200A (4-turn potentiometer) Monitored load current required to adjust setpoint
Output	Isolated solid state: Normally Open 0.15 A @ 120VAC or VDC	Isolated solid state: Normally Open 0.15 A @ 240VAC or VDC	Isolated solid state: Normally Open 0.15 A @ 240VAC or VDC Normally Closed 0.2 A @ 135VAC or VDC	Isolated solid state: Normally Open AC: 0.15 A @ 240VAC	Isolated solid state: Normally Open or Normally Closed AC model: 1A @ 240VAC Normally Open AC model: 3A @ 120VAC Normally Open or Normally Closed DC model: 0.15 A @ 30VDC	Isolated solid state: Normally Open 1A @ 240VAC	Two Independent Single Pole, Double Throw electro-mechanical relays AC: 1A @ 120VAC DC: 2A @ 30VDC	Isolated solid state: Normally Open or Normally Closed AC model: 1A @ 240VAC Normally Open AC/DC model: 0.15 A @ 240 VAC/ VDC Normally Closed AC/DC model: 0.2 A @ 135 VAC/ VDC
Frequency Range	50 to 400 Hz	6 to 100 Hz	6 to 100 Hz	10 to 100 Hz	6 to 100 Hz	40 to 100 Hz	40 to 65 Hz	50 to 100 Hz
Response Time	N/A	120ms	120ms	100ms & 2s inrush delay	40 to 250 ms	0.50 sec. 5% over set point 0.20 sec. 50% over set point 0.15 sec. 100% over set point	40 - 120ms	Field adjustable time delay: 0.12 to 15 seconds
Sensing Aperture	0.30 in [8.13 mm] dia.	Fixed core: 0.75 in [19mm] dia. Split core: 0.85 in [21.7 mm] sq.	Fixed core: 0.75 in [19mm] dia. Split core: 0.85 in [21.7 mm] sq.	Fixed core: 0.55 in [13.97 mm] dia. Split core: 0.85 in [21.7 mm] sq.	Fixed core: 0.55 in [13.97 mm] dia. Split core: 0.85 in [21.7 mm] sq.	0.75 in [19mm] dia.	1.31 in [33.3 mm] dia.	Fixed core: 0.75 in [19mm] dia. Split core: 0.85 in [21.7 mm] sq.

AC Current Switches, Transducers and Indicators

AcuAMP AC Current Transducer/Switch and Indicator Selection Guide			
Specifications	AC Current Transducer	AC Current Transducer/Switch	Indicator
Series	ACTH	ACTS	ACL1
Sensing Range	0 to 50A	1 to 200A	0 to 100A
Setpoint (Trip Point)	Not Applicable	Adjustable: (Single turn potentiometer): ACTS050: 1-50A ACTS200: 4-200A	Non-adjustable: 0.5 A
Output	4 -20 mA, loop-powered adaptive True RMS	4-20mA analog output and isolated solid state: Normally Open 1A @ 240VAC	LED Only (flashing, red)
Frequency Range	40 to 400 Hz	40 to 400 Hz	50 to 400 Hz
Response Time	400ms at 100% duty cycle, or duty cycle period plus 40ms	Switch: 0.50 sec. 5% over set point 0.20 sec. 50% over set point 0.15 sec. 100% over set point Analog: < 0.30 sec. 90% step change < 0.40 sec. 100% step change	N/A
Sensing Aperture	0.86 in [21.9 mm] sq.	0.75 in [19mm] dia.	0.30 in [7.6 mm] dia.



Click on the thumbnail or go to <https://VID-CT-0001> for a short introductory video on the AcuAmp Current Switches, Transducers and Indicators

AC Current Sensors, Switches and Transducers Application Guide

Application Guide

ACUAMP current sensors are a great fit for many applications including material handling, fan and pump applications, and heating systems. With current transducers, current switches and current indicators, this sensor family gives you

valuable data for processes ranging from monitoring loads to preventive maintenance. Models with the ability to read True RMS non-sinusoidal waveforms make it easy to monitor applications using variable frequency drives.

Use the application examples to help choose the best sensor model for your application.

Pump Jam & Suction Loss Protection

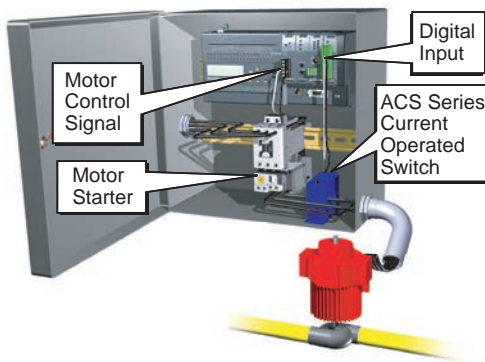

Heater Life Prediction

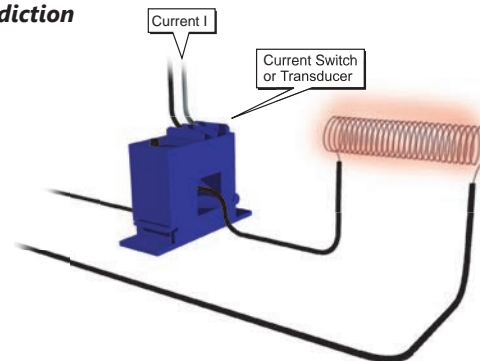

Crusher/Grinder/Shredder Motor Interlocks

The performance of size reduction equipment like crushers or grinders can be optimized by controlling the in-feed in order to:

- Help prevent jamming
- Improve the uniformity of the resultant product
- Enhance overall production efficiency

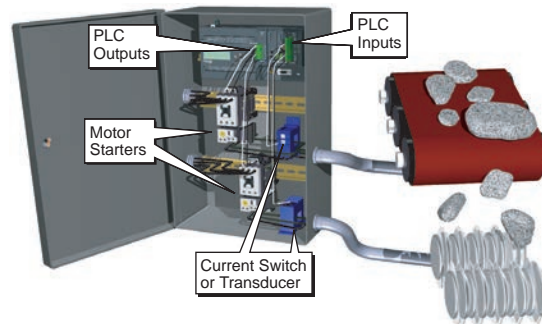

Pump Load Monitoring

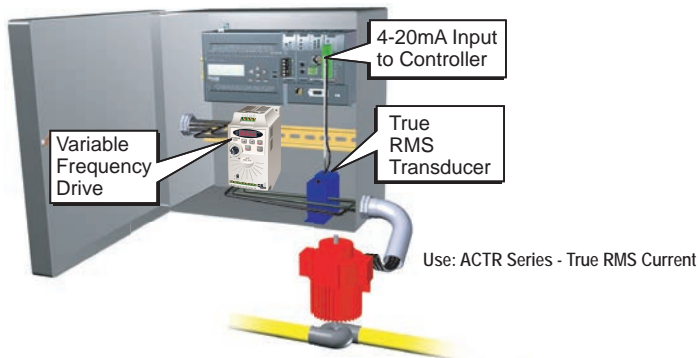

Lamp Failure Detection

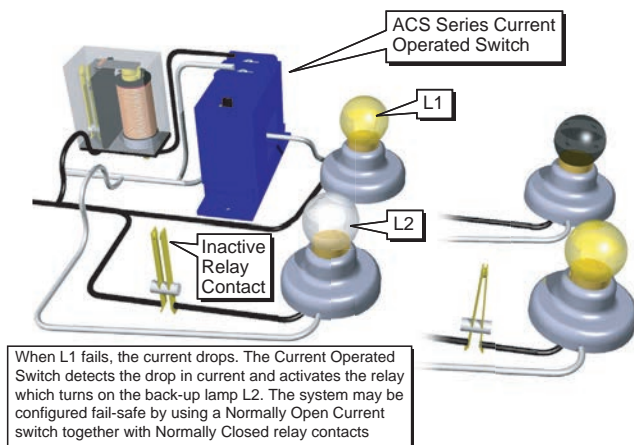

Electric Motor Load Status

