

# ACUAMP<sup>®</sup> ACTH Series AC Current Transducers



## Applications

### Electrical Heaters

- Zero-crossing burst fired SCR controllers
- Faster response than temperature sensors.
- Simplest method to monitor pulsed waveforms.

Monitoring the current controlled by silicon-controlled rectifiers (SCRs) can be a challenge, especially the current used by heaters. Zero-crossing burst fired controls allow current to flow to the circuit for as short of a time period as one cycle, and off for several cycles. Most current sensors will not work well when there is no current present.

When used to monitor zero-crossing burst fired SCRs, the ACTH series uses an innovative time integration adaptive True RMS measurement method that will provide an output signal directly proportional to the RMS amperage even when the SCR controller is providing power in one cycle increments.

## Features

- 4–20 mA output
- Compatible with most automation systems.
- Split core models powered with 24 VAC or DC
- Factory Calibrated, no need for zero and span adjustment potentiometers.
- RMS Output accurate measurement of sinusoidal or pulsed current wave shapes.
- Built-in mounting feet with optional DRA-2B 35mm DIN rail adapter available.
- Five-year warranty



ACTH Series AC Current Transducers				
Part Number	Description	Pcs/Pkg	Wt (lb)	Price
ACTH005-42-24-S	AcuAMP AC current transducer, split core, 0-2, 0-5A selectable, with time integration sensing range, 4-20mA output.	1	0.35	
ACTH050-42-24-S	AcuAMP AC current transducer, split core, 0-10, 0-20, 0-50A selectable, with time integration sensing range, 4-20mA output.	1	0.35	
Accessories				
DRA-2B	35mm DIN rail adapters, 1.70"x0.45"x0.83" [43.7x11.4x21.0 mm]	2	0.40	

Specifications	
<b>Power Supply</b>	24 VAC/DC (+/-10%) <i>Intended for use with a Class 2 source with the secondary fused to limit power to a maximum of 100 VA</i>
<b>Power Consumption</b>	< 2VA
<b>Output Signal</b>	4-20 mA
<b>Output Limit</b>	100% of standard output range maximum value
<b>Frequency Range</b>	40-400 Hz, Adaptive True RMS
<b>Response Time</b>	400ms at 100% duty cycle, or duty cycle period plus 40ms
<b>Accuracy</b>	1.0% Full Scale
<b>Output Impedance</b>	500Ω maximum
<b>Isolation Voltage</b>	UL tested to 1240VAC
<b>Case</b>	UL 94V-0 Flammability rated thermoplastic
<b>Environmental</b>	-Temp -4 to 122°F (-20 to 50°C) -Humidity 0-95% RH, Non-condensing -Pollution degree 2 -Altitude 2000 meters
<b>Certifications</b>	cULus listed E197592 CE

Sensed Current Limit			
Model	Range	Max. 6 Seconds	Max. 1 Second
ACTH005	0 - 2A	125	250
	0 - 5A	125	250
ACTH050	0 - 10A	125	250
	0 - 20A	150	300
	0 - 50A	215	400

# ACUAMP® ACTH Series AC Current Transducers

## Wiring

### ACTH Series

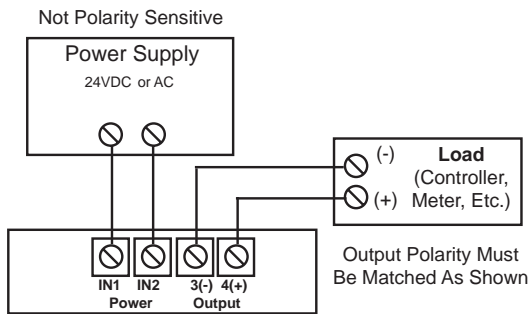

## Dimensions

Inches [mm]

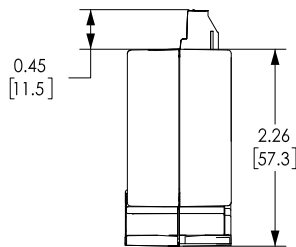
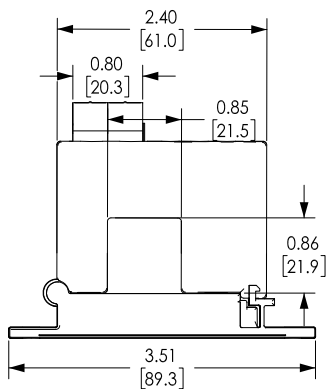
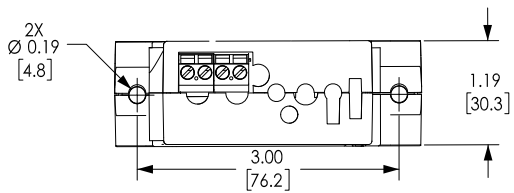

See our website [www.acuamp.com](#) for complete Engineering drawings.

## Application Example

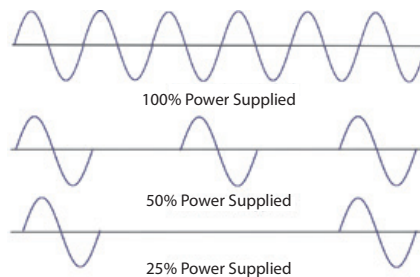
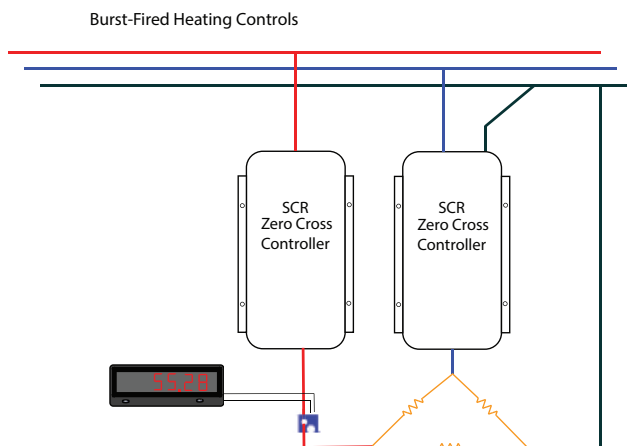

ACTH Series AC current transducers will produce a signal proportional to the current used even when the controller is supplying power in one cycle increments.



# AC Current Switches, Transducers and Indicators

## Overview

The AcuAMP series of AC current sensors is a family of high-performance current sensors offering outstanding features, flexibility, and durability at an incredible Price. Choose from a wide selection of current transducers, switches and indicators, all designed in a rugged industry-standard feed-through package, including both fixed core and split core models.

AcuAMP current sensors are available with

a broad selection of input sensing ranges for maximum flexibility across many current ratings. The current transducer output choices include 4-20 mA, 24VDC loop-powered, and 0 to 10 volt self-powered analog outputs. The Current Switch outputs include isolated solid state switches available in Normally Open and Normally Closed configurations or SPDT relays.

Models with output time delay are also offered in the Current Switch series. The

ACL1 Current Indicator senses AC current ranging from 0.5 to 100A and requires no power for the indicating LED.

These current sensors can be mounted in a panel or attached to the monitored conductor with a wire tie. Use the Selection Guide below to find the best sensor for your requirements.



**AcuAMP AC Current Transducer Selection Guide**

Specifications	Single-Phase Transducer	Single-Phase Transducer (True RMS)	3-Phase Transducer	3-Phase Transducer (True RMS)
Series	ACT	ACTR	3ACT	3ACTR
<b>Sensing Range</b>	Selectable: ACT005: 0 to 2A 0 to 5A ACT050: 0 to 10A 0 to 20A 0 to 50A ACT200: 0 to 100A 0 to 150A 0 to 200A ACT750: 0 to 375A 0 to 500A 0 to 750A ACT2000: 0 to 1000A 0 to 1333A 0 to 2000A Fixed range: ACT400 0 to 400A ACT600 0 to 600A ACT800 0 to 800A ACT1200 0 to 1200A	Selectable: ACTR005: 0 to 2A 0 to 5A ACTR050: 0 to 10A 0 to 20A 0 to 50A ACTR200: 0 to 100A 0 to 150A 0 to 200A ACTR750: 0 to 375A 0 to 500A 0 to 750A ACTR2000: 0 to 1000A 0 to 1333A 0 to 2000A Fixed range: ACTR400: 0 to 400A ACTR500: 0 to 500A ACTR600: 0 to 600A ACTR800: 0 to 800A ACTR1000: 0 to 1000A ACTR1200: 0 to 1200A ACTR2000: 0 to 2000A	Selectable: 3ACT030: 0 to 10A 0 to 15A 0 to 30A 3ACT100: 0 to 30A 0 to 50A 0 to 100A 3ACT200: 0 to 100A 0 to 150A 0 to 200A	Selectable: 3ACTR030: 0 to 10A 0 to 15A 0 to 30A 3ACTR100: 0 to 30A 0 to 50A 0 to 100A 3ACTR200: 0 to 100A 0 to 150A 0 to 200A
<b>Output</b>	-10 models: 0-10 VDC, self-powered -42L models: 4-20 mA, loop-powered	4-20 mA, loop-powered True RMS	4 -20 mA, loop-powered	4-20 mA, loop-powered True RMS
<b>Frequency Range</b>	-10 models: 50 to 60 Hz -42L models up to 200A: 20 to 100 Hz -42L models 400, 600, 800, 1200A: 50 to 60 Hz sinusoidal waveforms only	20 to 400 Hz; (40 to 400 Hz flexible split core models) sinusoidal and non-sinusoidal waveforms	50 to 60 Hz sinusoidal waveforms only	30 to 100 Hz sinusoidal and non-sinusoidal waveforms
<b>Sensing Aperture</b>	ACT005, ACT050, ACT200: Fixed core: 0.75 in [19mm] dia. Split core: 0.85 in [21.6 mm] sq. ACT750, ACT2000: Fixed core: 3.0 in [76.2 mm] dia. ACT400, ACT600, ACT800: Split core: 2.22 X 1.19 in [56.3 X 30.2 mm] ACT1200 Split core: 3.44 X 2.31 in [87.3 X 58.8 mm]	ACTR005, ACTR050, ACTR200: Fixed core: 0.75 in [19mm] dia. Split core: 0.85 in [21.6 mm] sq. ACTR750, ACTR2000: Fixed core: 3.0 in [76.2 mm] dia. ACTR500, ACTR1000, ACTR2000: Flexible split core: 4.5 in [114.3 mm] dia. ACTR400, ACTR600, ACTR800: Split core: 2.22 X 1.19 in [56.3 X 30.2 mm] ACTR1200 Split core: 3.44 X 2.31 in [87.3 X 58.8 mm]	3x - Fixed core: 0.86 in [21.8 mm] dia.	3x - Fixed core: 0.86 in [21.8 mm] dia.



# AC Current Switches, Transducers and Indicators

AcuAMP AC Current Switch Selection Guide								
Specifications	AC Current Switches							
Series	ACSN100	ACSN250	ACS150	ACSL	ACS200	ACS050/ACS200	ACS035/ACS400	ACSX
<b>Sensing Range</b>	0 to 100A	0 to 250A	Fixed core: 1 to 150A Split core: 1.75 to 150A	0 to 50A	Jumper Selectable:  Fixed core: 1 to 6A 6 to 40A 40 to 175A Split core: 1.75 to 6A 6 to 40A 40 to 200A	1 to 200A	2 to 400A	Jumper Selectable:  Fixed core: 1.5 to 12A 12 to 55A 55 to 175A Split core: 2 to 12A 12 to 55A 55 to 200A
<b>Setpoint (Trip Point)</b>	Non-adjustable: 0.5 A	Non-adjustable: Fixed core: 0.75A Split core: 1.25A	Adjustable: Fixed core: 1-150 A (15-turn potentiometer) Split core: 1.75-150 A (4-turn potentiometer) Monitored load current required to adjust setpoint	Adjustable (3/4-turn potentiometer): ACSL010: 1-10A ACSL020: 2-20A ACSL050: 10-50A Monitored load current not required to adjust setpoint	Adjustable: (4-turn or 15-turn potentiometer) Fixed core: 1-175A Split core: 1.75-200A Monitored load current required to adjust setpoint	Adjustable: (Single turn potentiometer): ACS050: 1-50A ACS200: 4-200A	Adjustable: (3/4-turn potentiometer): ACS035: 2-35A ACS400: 25-400A	Adjustable: Fixed core: 1.5-175A (15-turn potentiometer) Split core: 2-200A (4-turn potentiometer) Monitored load current required to adjust setpoint
<b>Output</b>	Isolated solid state:  Normally Open 0.15 A @ 120VAC or VDC	Isolated solid state:  Normally Open 0.15 A @ 240VAC or VDC	Isolated solid state:  Normally Open 0.15 A @ 240VAC or VDC  Normally Closed 0.2 A @ 135VAC or VDC	Isolated solid state:  Normally Open AC: 0.15 A @ 240VAC	Isolated solid state:  Normally Open AC model: 1A @ 240VAC  Normally Open AC model: 3A @ 120VAC  Normally Open or Normally Closed DC model: 0.15 A @ 30VDC	Isolated solid state: Normally Open 1A @ 240VAC	Two Independent Single Pole, Double Throw electro-mechanical relays AC: 1A @ 120VAC DC: 2A @ 30VDC	Isolated solid state:  Normally Open or Normally Closed AC model: 1A @ 240VAC  Normally Open AC/DC model: 0.15 A @ 240 VAC/ VDC Normally Closed AC/DC model: 0.2 A @ 135 VAC/ VDC
<b>Frequency Range</b>	50 to 400 Hz	6 to 100 Hz	6 to 100 Hz	10 to 100 Hz	6 to 100 Hz	40 to 100 Hz	40 to 65 Hz	50 to 100 Hz
<b>Response Time</b>	N/A	120ms	120ms	100ms & 2s inrush delay	40 to 250 ms	0.50 sec. 5% over set point 0.20 sec. 50% over set point 0.15 sec. 100% over set point	40 - 120ms	Field adjustable time delay: 0.12 to 15 seconds
<b>Sensing Aperture</b>	0.30 in [8.13 mm] dia.	Fixed core: 0.75 in [19mm] dia. Split core: 0.85 in [21.7 mm] sq.	Fixed core: 0.75 in [19mm] dia. Split core: 0.85 in [21.7 mm] sq.	Fixed core: 0.55 in [13.97 mm] dia. Split core: 0.85 in [21.7 mm] sq.	Fixed core: 0.55 in [13.97 mm] dia. Split core: 0.85 in [21.7 mm] sq.	0.75 in [19mm] dia.	1.31 in [33.3 mm] dia.	Fixed core: 0.75 in [19mm] dia. Split core: 0.85 in [21.7 mm] sq.

# AC Current Switches, Transducers and Indicators

AcuAMP AC Current Transducer/Switch and Indicator Selection Guide			
Specifications	AC Current Transducer	AC Current Transducer/Switch	Indicator
Series	ACTH	ACTS	ACL1
<b>Sensing Range</b>	0 to 50A	1 to 200A	0 to 100A
<b>Setpoint (Trip Point)</b>	Not Applicable	Adjustable: (Single turn potentiometer): ACTS050: 1-50A ACTS200: 4-200A	Non-adjustable: 0.5 A
<b>Output</b>	4 -20 mA, loop-powered adaptive True RMS	4-20mA analog output and isolated solid state: Normally Open 1A @ 240VAC	LED Only (flashing, red)
<b>Frequency Range</b>	40 to 400 Hz	40 to 400 Hz	50 to 400 Hz
<b>Response Time</b>	400ms at 100% duty cycle, or duty cycle period plus 40ms	Switch: 0.50 sec. 5% over set point 0.20 sec. 50% over set point 0.15 sec. 100% over set point  Analog: < 0.30 sec. 90% step change < 0.40 sec. 100% step change	N/A
<b>Sensing Aperture</b>	0.86 in [21.9 mm] sq.	0.75 in [19mm] dia.	0.30 in [7.6 mm] dia.



Click on the thumbnail or go to <https://VID-CT-0001> for a short introductory video on the AcuAmp Current Switches, Transducers and Indicators

# AC Current Sensors, Switches and Transducers Application Guide

## Application Guide

ACUAMP current sensors are a great fit for many applications including material handling, fan and pump applications, and heating systems. With current transducers, current switches and current indicators, this sensor family gives you

valuable data for processes ranging from monitoring loads to preventive maintenance. Models with the ability to read True RMS non-sinusoidal waveforms make it easy to monitor applications using variable frequency drives.

Use the application examples to help choose the best sensor model for your application.

### Pump Jam & Suction Loss Protection

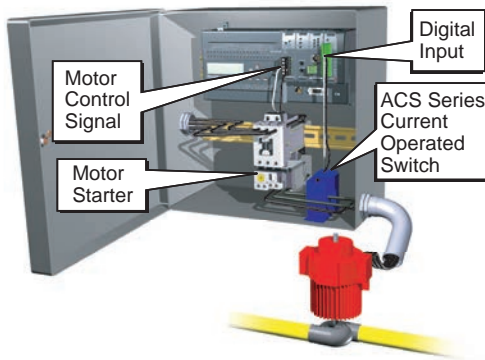

### Heater Life Prediction

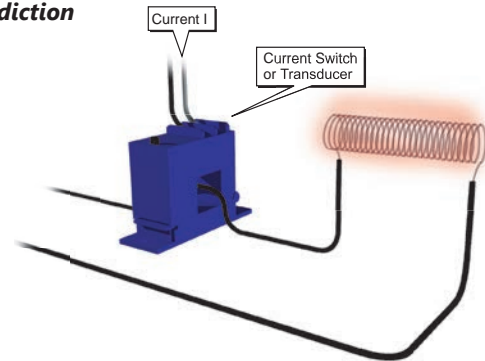

### Crusher/Grinder/Shredder Motor Interlocks

The performance of size reduction equipment like crushers or grinders can be optimized by controlling the in-feed in order to:

- Help prevent jamming
- Improve the uniformity of the resultant product
- Enhance overall production efficiency

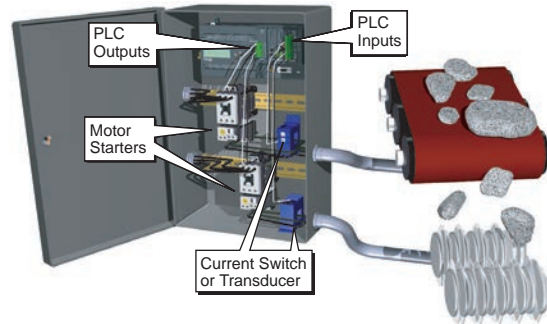

### Pump Load Monitoring

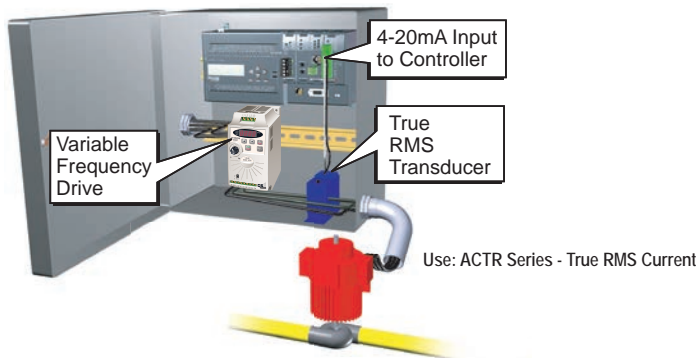

### Lamp Failure Detection

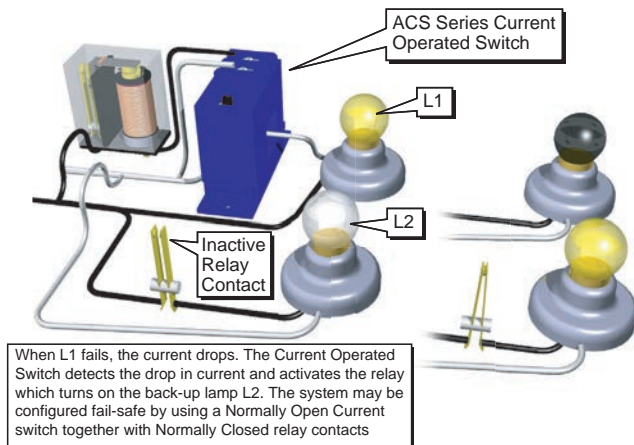

### Electric Motor Load Status

