

proense® Alternating Relays



AR-TL



ARX-TL

Overview

AR-TL Series

Alternating relays are used in special applications where the optimization of load usage is required by equalizing the run time of two loads. The alternating action is initiated by a control switch, such as a float switch, manual switch, timing delay, pressure switch, or other isolated contact. Each time the initiating switch is opened, the output relay contacts will change state, thus alternating the two loads. Two LED indicators show which load to energize next.

The alternating relay can be used with one or two control switches and is available in a SPDT output configuration.

The AR-TL Series Relays have a three-position selector switch. This allows the unit to alternate the two loads as normal, or lock the relay to one load or the other. By locking the alternating relay to one load, the other load can be removed for service without rewiring the first load for continuous operation. The selector switch has a low profile to prevent any accidental changes in status.

ARX-TL Series

Alternating relays with DPDT cross-wired outputs are used in applications requiring both (a) the optimization of load usage by equalizing the run time of two loads and (b) additional capacity in case of excess load requirements. The alternating action is initiated by a control switch, such as a float switch, manual switch, timing relay, pressure switch, or other isolated contact. Each time the initiating switch is opened, the output relay contacts will change state, thus alternating the two loads. Two LED indicators show the load to energize next.

Alternating relays with DPDT cross-wired output configurations can be used with two or three control switches.

The ARX-TL series relays have a three-position selector switch. This allows a DPDT cross-wired unit to alternate the two loads as normal, or lock the relay to always operate the same load first each time. In this manner, a load that has fewer hours of operation than the other load could be used more often in an effort to eventually balance the run time of both loads.

Features

AR-TL

- For duplex loads
- 10A SPDT output configuration
- Can be used with one or two control switches
- 120VAC Control voltage
- Compact plug-in design utilizing industry-standard 8-pin octal socket
- Low profile selector switch to lock in load
- 2 LEDs indicate load to energize next

ARX-TL

- For duplex loads
- 10A DPDT cross-wired output configuration
- Can be used with two or three control switches
- 120VAC control voltage
- Compact plug-in design utilizing industry-standard 8-pin octal socket
- Low profile selector switch to lock either load ON first
- 2 LEDs indicate load to energize first

Agency Approvals

- cURus, File number E191059
- UL Listed, File number E191059
- CE

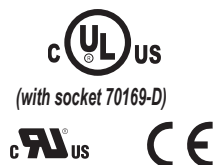

pro^{sense} Alternating Relays

Alternating Relays				
Part Number	Price	Description	Use With	Drawing Links
AR-1C-120A-TL		ProSense alternating relay, socket mount, finger-safe, 120 VAC coil voltage, SPDT, 10A contact rating, 8-pin, LED indicator(s). Relay becomes UL listed when used with 70169-D relay socket.	70169-D or 750-2C-SKT	PDF
ARX-2C-120A-TL		ProSense alternating relay, socket mount, finger-safe, 120 VAC coil voltage, DPDT, 10A contact rating, 8-pin, LED indicator(s). Relay becomes UL listed when used with 70169-D relay socket.		PDF
70169-D		Relay socket, 8-pin, 35mm DIN rail or panel mount. For use with ProSense octal relays.	-----	PDF
750-2C-SKT		AutomationDirect relay socket, 8-pin, 35mm DIN rail or panel mount. For use with 750-2C and H750-2C series octal relays.	-----	PDF

Technical Specifications		
Part Number	AR-1C-120A-TL	ARX-2C-120A-TL
Voltage Tolerance	120VAC 50/60Hz (+10% / -15%)	
Output Contacts	SPDT: 10A @ 240V AC/24V DC 1/2HP @ 120/240V AC (N.O.) 1/3HP @ 120/240VAC (N.C.) B300, R300 (N.O.) Pilot Duty	DPDT: 10A @ 240V AC/24V DC 1/2HP @ 120/240V AC (N.O.) 1/3HP @ 120/240VAC (N.C.) B300, R300 (N.O.) Pilot Duty
Life (Resistive Load)	Mechanical: 10,000,000 operations; Electrical - Resistive: 100,000 operations	
Power Consumption	Less than 3VA	
Temperature	Operating: -28 to 65°C (-18 to 149°F) Storage: -40 to 85°C (-40 to 185°F)	
Mounting	8-pin octal socket	
Indicator LED	2 LEDs marked LOAD 1 and LOAD 2	
Selector Switch Settings	LOAD 1 ALTERNATE LOAD 2	LOAD 1 (Always energizes first) ALTERNATE LOAD 2 (Always energizes first)
Weight (lb)	0.3	
Approvals	cURus, (E191059), CE, (cULus when used with socket 70169-D)	

Wiring Diagrams

AR-1C-120A-TL

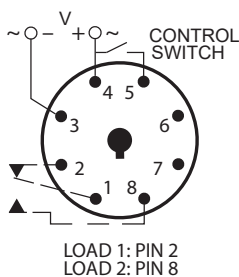

ARX-2C-120A-TL

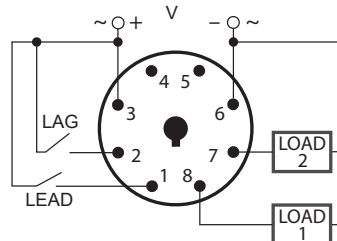

proense® Alternating Relays

Typical Installations

When using the AR series relay with the selector switch in the "Alternate" position in the initial off state (Figure A), the Control Switch is open, the Alternating Relay is in the "LOAD 1" position, and both loads (M1 and M2) are off. The red LED marked "LOAD 1" is ON. When the Control Switch closes, it energizes Load M1. As long as the Control Switch remains closed, Load M1 remains energized. When the Control Switch opens, Load M1 is turned off and the Alternating Relay toggles to the "LOAD 2" position. The red LED marked "LOAD 2" glows. When the Control Switch closes

again, it energizes Load M2. When the Control Switch opens, Load M2 is turned off, the Alternating Relay toggles back to the "LOAD 1" position, and the process can be repeated again. On relays with DPDT contacts, two pilot lights can be used for remote indication of "LOAD 1" or "LOAD 2" status.

To eliminate any bounce condition of the Control Switch, the addition of a second switch (OFF) along with two auxiliary contacts is recommended as shown (Figure B).

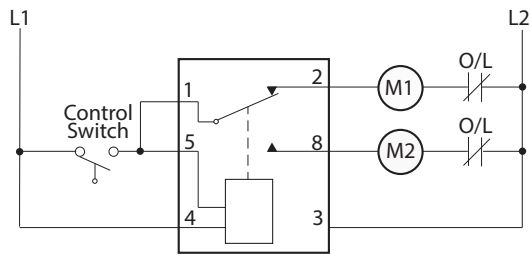

Figure A

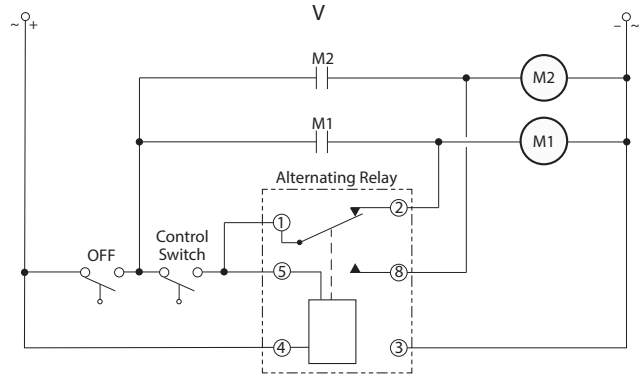

Figure B

When using the ARX series relay with the selector switch in the "Alternate" position in the initial off state (Figure C), both the LEAD Control Switch and the LAG Control Switch are open, the Alternating Relay is in the "LOAD 1" position, and both loads are off. The red LED marked "LOAD 1" is ON. When the LEAD Control Switch closes, it energizes Load M1. As long as the LEAD Control Switch remains closed, Load M1 remains energized. If the LAG Control Switch closes, it energizes Load M2. When the LAG Control Switch opens, Load M2 is turned off. When the LEAD Control Switch opens, Load M1 is turned off and the Alternating Relay toggles to the "LOAD 2" position. The red LED marked "LOAD 2" is ON. When the LEAD Control Switch closes, it turns on Load M2. If the LAG Control Switch closes, it will energize Load M1. When the LAG Control Switch opens, Load M1 is turned off. When the LEAD Control Switch opens, Load M2 is turned off, the Alternating Relay toggles back to the "LOAD 1" position, and the process can be repeated again.

A type of operation known as "Sequence On - Simultaneously Off (S.O.S.O.)" where the two loads are energized sequentially, but remain on together until the OFF switch is opened (Figure D). In the initial OFF state, all three switches are open, the Alternating Relay is in the "LOAD 1" position, and both loads are off. No action happens with the Alternating Relay or either load when the OFF Switch closes. When the LEAD Switch closes, Load M1 turns on. When the LAG Switch closes, Load M2 turns on. Both loads remain on as long as all three switches are closed. When the LAG Switch opens, Load M2 remains on because the OFF Switch is still closed. When the LEAD Switch opens, Load M1 remains on because the STOP Switch is still closed. When the OFF Switch opens, both Load M1 and Load M2 are turned off simultaneously. The Alternating Relay toggles to the "LOAD 2" position. The entire cycle is then repeated, but with Load M2 energized first followed by Load M1.

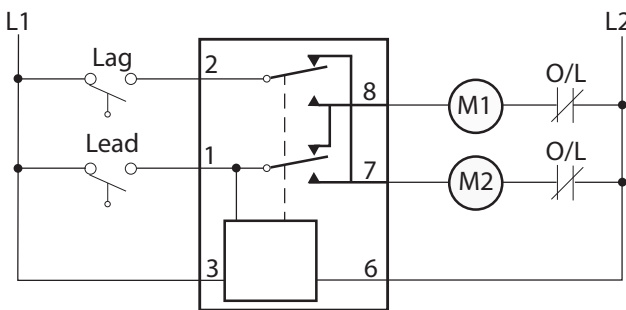

Figure C

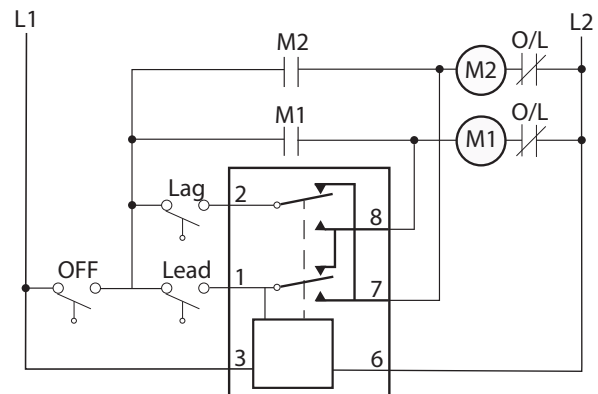

Figure D

Note: M1 and M2 reference in Figures A,B,C and D are coils.

proSense® Octal Sockets

Features

- Mounts on 35mm DIN rail
- Screw clamp wire termination



70169-D



70170-D



750-2C-SKT

Octal Sockets for Relays

Part Number	Price	Description	Qty	Wt (lb)	Drawing Links
<u>70169-D</u>		Relay socket, 8-pin, 35mm DIN rail or panel mount. For use with ProSense octal relays.	1	0.1	<u>PDF</u>
<u>70170-D</u>		Relay socket, 11-pin, 35mm DIN rail or panel mount. For use with ProSense octal relays.	1	0.1	<u>PDF</u>
<u>750-2C-SKT</u>		AutomationDirect relay socket, 8-pin, 35mm DIN rail or panel mount. For use with 750-2C and H750-2C series octal relays.	1	0.1	<u>PDF</u>

Octal Sockets Specifications

Part Number	Number of Pins	Voltage	Current	Screw Size	Wire Size (capacity)	Screw Torque	Screw Chassis Mounting Torque	Agency Approval
<u>70169-D</u>	8	600V	10A	6-32	1 or 2, 12-20 AWG	12 in-lb	7 in-lb	UL Recognized E169693, CSA, CE
<u>70170-D</u>	11	300V	10A	6-32	1 or 2, 12-20 AWG	12 in-lb	12 in-lb	
<u>750-2C-SKT</u>	8	600V	5A	M3.5	1-12 AWG / 1-14 AWG	9 in-lb	7 in-lb	UL Recognized E225080, CSA, CE

Socket Pinouts

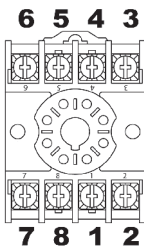

70169-D

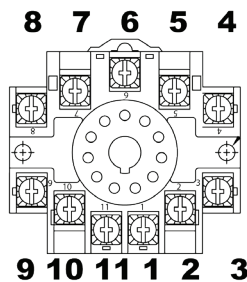

70170-D

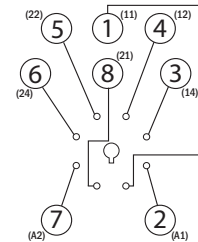

750-2C-SKT