

ASO Safety Solutions

60mm x 100mm SENTIR Bumpers



1701-3690

Adaptable, extremely versatile and totally reliable – these qualities are the hallmarks of our SENTIR safety bumpers. These safety bumpers are highly valued in a wide range of applications from those involving transport vehicles and industrial trucks to high-shelf warehouses, production lines, or mobile systems – in fact, anywhere that a flexible safety bumper solution is required.

Features

- Mounting rail included
- Insensitive to vibration
- Reliable switching operation in rugged applications
- Can wire in 2-wire or 4-wire circuits

ASO Safety Solutions SENTIR Bumpers - 60mm x 100mm						
Part Number	Price	Profile	Length	Aluminum Mounting Rail	Cable Length	Connection Cables
1701-3690		60 x 100mm (2.36 x 3.94 ft)	1ft (0.30 m)	Included	Two cables, each 4.7 in (120mm) in length	One cable has a 3-pin male M8 connector. The other cable has a 3-pin female M8 connector.
1701-3700			1.5 ft (0.46 m)			
1701-3710			2ft (0.61 m)			
1701-3720			2.5 ft (0.76 m)			
1701-3730			3ft (0.91 m)			

M8 Connector

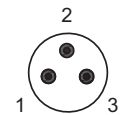

Use pins 1 and 3 for continuity. (See safety relay for wiring)



1810-0190

ASO Safety Solutions Terminating Resistors				
Part Number	Price	Description	Use With	Contents
1810-0190		Terminating resistor, 8.2 k ohm, 3-pin male M8 connector	Safety contact mats and bumpers	1 resistor

ASO Safety Solutions

60mm x 100mm SENTIR Bumpers

ASO Safety Solutions SENTIR Bumpers - 60mm x 100mm	
	General Specifications
Material	Artificial leather
Material Hardness	N/A
Weight (per meter)	440g (5.5 oz) per meter
Protection Class (Enclosure)	IP54
Switching Cycles	>10,000 (UL 325)
Switching Angle	±45°
Actuation Resistance	≤ 500 Ohms
Actuation Force	Test piece Ø 80mm (3.15 in) = approximately 150N
Mechanical Life	10,000 cycles
Electrical Capacity	24VDC, 10mA
Max. Temperature Range	-25° to +75°C (-13° to +167°F)
Operating Temperature	-10° to +50°C (+14° to +122°F)
Max. Series Connection	5 contact edges or 100m [328.08 ft] based on the ASO safety relay 1114-0210
Inactive End Region with Higher Forces	30mm (1.18 in)
Cable Material	Polyurethane matte black
Agency Approvals	UL Recognized file E341185, CE

Dimensions

mm [in]

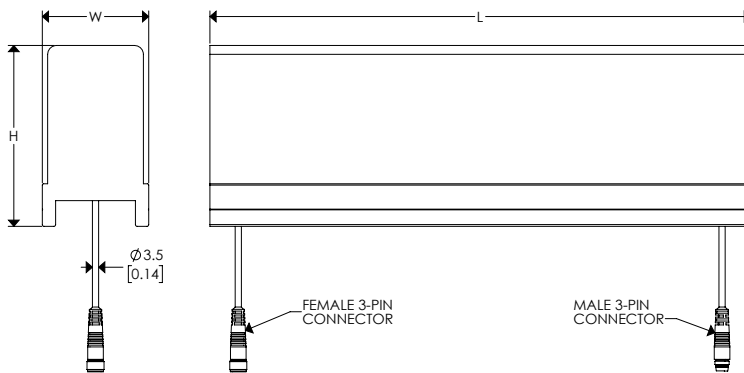

Part Information – 60mm x 100mm ASO SENTIR Bumpers			
Part number	W	H	L
1701-3690	60mm (2.36 in)	100mm (3.94 in)	1ft (0.30 m)
1701-3700			1.5 ft (0.46 m)
1701-3710			2ft (0.61 m)
1701-3720			2.5 ft (0.76 m)
1701-3730			3 ft (0.91 m)

Safety Products



Warning: Safety products sold by AutomationDirect are Safety components only. The purchaser/installer is solely responsible for the application of these components and ensuring all necessary steps have been taken to assure each application and use meets all performance and applicable safety requirements and/or local, national and/or international safety codes as required by the application. AutomationDirect cannot certify that our products, used solely or in conjunction with other AutomationDirect or other vendors' products, will assure safety for any application. Any person using or applying any products sold by AutomationDirect is responsible for learning the safety requirements for their individual application and applying them, and therefore assumes all risks, and accepts full and complete responsibility, for the selection and suitability of the product for their respective application.

AutomationDirect does not provide design or consulting services, and cannot advise whether any specific application or use of our products would ensure compliance with the safety requirements for any application.