

C-more Micro 3-inch EA1 STN Touch Panel

Model [EA1-S3ML](#) **C-more** 3-inch Micro touch panel has a 3.1-inch STN LCD monochrome display and five selectable LED-driven backlight colors: Green, Red, Amber, Yellow and Lime. It features a 128 x 64 pixel display, and five user-defined function keys each with a user-defined red LED indicator. The panel can display up to 10 lines by 32 characters of static text and up to 10 lines by 21 characters of dynamic text with embedded variables and phrases mixed with graphics. It is rated UL for use on a flat surface of Type 1, 4X enclosure (for indoor use only). This Micro panel can receive power from the serial communications port of most AutomationDirect PLCs.

Part No. [EA1-S3ML](#)

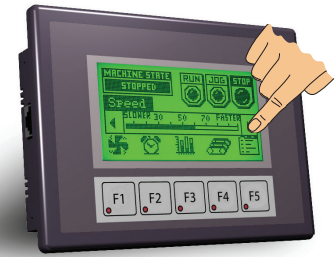

Features

- Touch screen display
- Free downloadable programming software
- 128 x 64 pixel display with up to 10 lines by 32 characters of text and graphics
- Up to 10 lines by 21 characters of dynamic text with embedded variables and phrases mixed with graphics
- 5 programmable function keys can change with every screen. Can increment / decrement values, trigger recipes, view index of screens.
- 5-Color LED backlight for longer lifetime; Green, Red, Amber, Yellow and Lime
- 2 optional snap-on keypad bezels
- 768 KB memory
- Panel is powered from PLC comm port when using select AutomationDirect PLCs. Use optional DC power adapter and serial port modules if needed for other controllers (RS-232/422/485)
- Built in Alarm Control setup that activates beep, backlight flash, customized alarm banner, and LED blinking
- 0 to 50 °C (32 to 122 °F) operating temperature range (IEC 60068-2-14)
- NEMA 4/4X, IP65 compliant when mounted correctly, indoor use only
- UL, cUL & CE agency approvals
- 2-year warranty from date of purchase



NOTE: Don't forget the optional keypad bezels, DC power adapter and serial port with DC power adapter shown in the Accessories.

Function	Available
Ethernet	No
USB Programming Port	No
Serial RJ12 Port	Yes

Dimensions

Units: inches [mm]

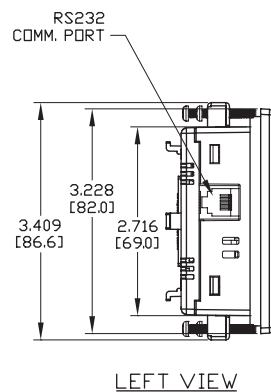
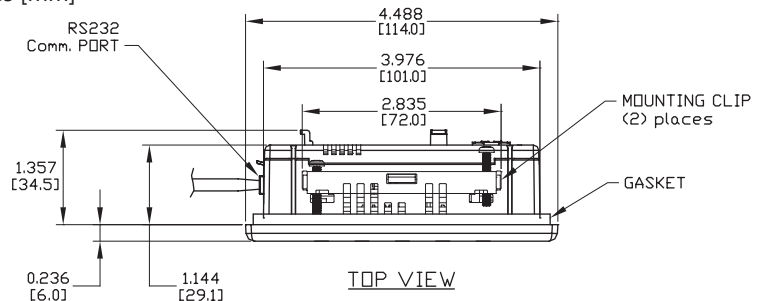

C-more Micro-Graphic Panel

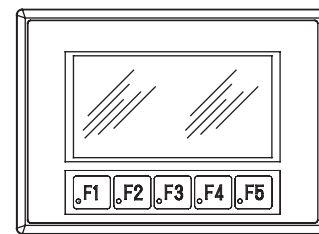

FRONT VIEW

Panel Cutout

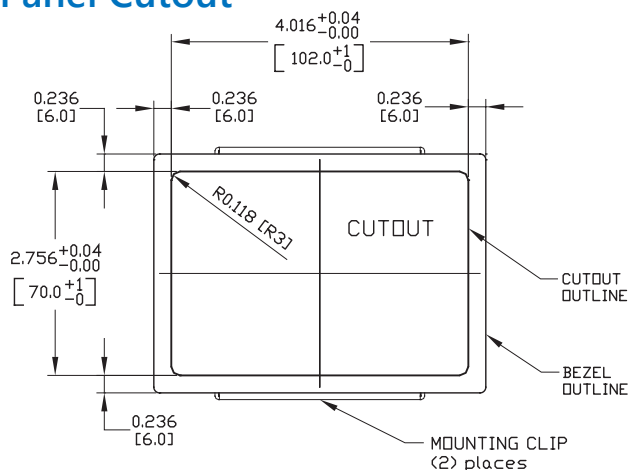

Panel Thickness

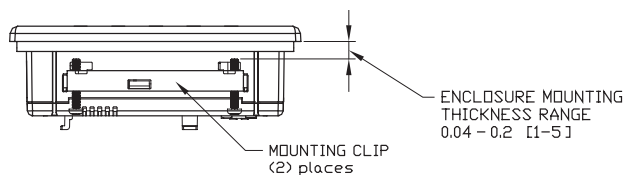

NOTE: The **C-more** 3-inch Micro cutout dimensions are not equivalent to previous AutomationDirect text panels. The **C-more** Micro panels will not fit in cutouts for DV-1000, EZText or Optimate panels.

C-more Micro 3-inch EA1 STN Touch Panel

Model [EA1-S3MLW](#) **C-more** 3-inch Micro touch panel has a 3.1-inch STN LCD monochrome display and five selectable LED-driven backlight colors: White, Pink1, Pink2, Pink3 and Red. It features a 128 x 64 pixel display, and five user-defined function keys each with a user-defined red LED indicator. The panel can display up to 10 lines by 32 characters of static text and up to 10 lines by 21 characters of dynamic text with embedded variables and phrases mixed with graphics. It is rated UL for use on a flat surface of Type 1, 4X enclosure (for indoor use only). This Micro panel can receive power from the serial communications port of most AutomationDirect PLCs.

Part No. [EA1-S3MLW](#)



Features

- Touch screen display
- Free downloadable programming software
- 128 x 64 pixel display with up to 10 lines by 32 characters of text and graphics
- Up to 10 lines by 21 characters of dynamic text with embedded variables and phrases mixed with graphics
- 5 programmable function keys can change with every screen. Can increment / decrement values, trigger recipes, view index of screens.
- 5-Color LED backlight for longer lifetime; White, Pink1, Pink2, Pink3 and Red
- 2 optional snap-on keypad bezels
- 768 KB memory
- Panel is powered from PLC comm port when using select AutomationDirect PLCs. Use optional DC power adapter and serial port modules if needed for other controllers (RS-232/422/485)
- Built-in Alarm Control setup that activates beep, backlight flash, customized alarm banner, and LED blinking
- 0 to 50 °C (32 to 122 °F) operating temperature range (IEC 60068-2-14)
- NEMA 4/4X, IP65 compliant when mounted correctly, indoor use only
- UL, cUL & CE agency approvals
- 2-year warranty from date of purchase

Function	Available
Ethernet	No
USB Programming Port	No
Serial RJ12 Port	Yes

Dimensions

Units: inches [mm]

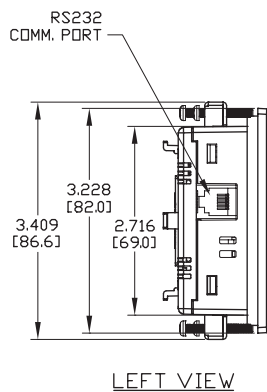
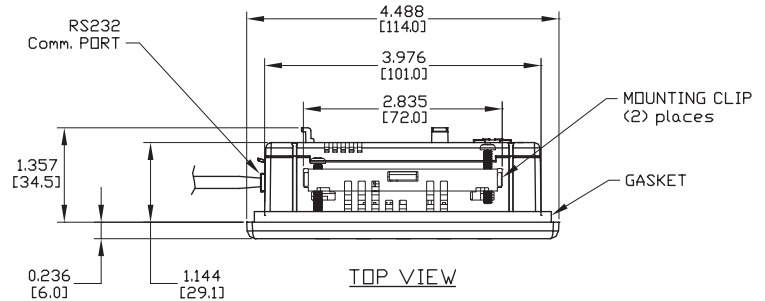

C-more Micro-Graphic Panel

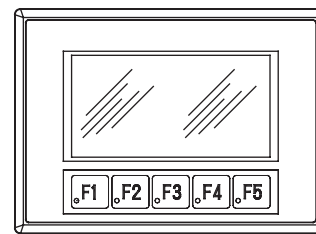

FRONT VIEW

NOTE: Don't forget the optional keypad bezels, DC power adapter and serial port with DC power adapter shown in the Accessories.

Panel Cutout

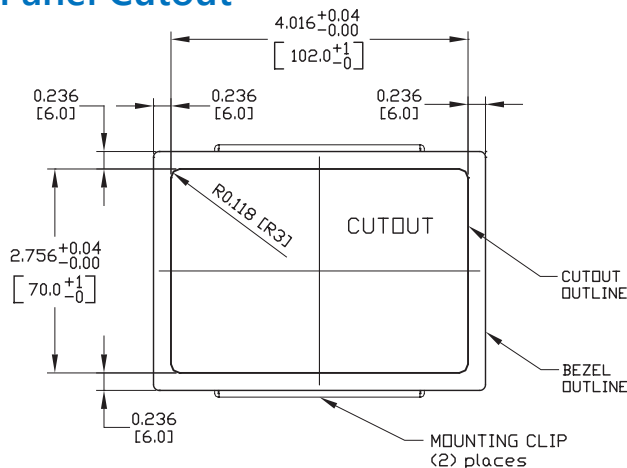

Panel Thickness

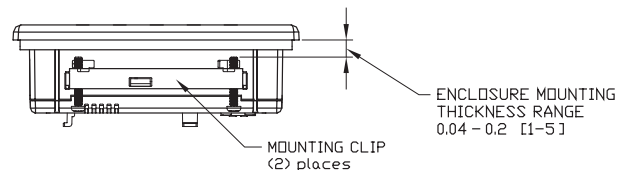

NOTE: The **C-more** 3-inch Micro cutout dimensions are not equivalent to previous AutomationDirect text panels. The **C-more** Micro panels will not fit in cutouts for DV-1000, EZText or Optimate panels.

C-more Micro 3-inch EA1 Specifications

Specification	Model	3-inch STN Micro Panel Touch Screen	3-inch STN Micro Panel Non-Touch Screen
Part Number		<u>EA1-S3ML, EA1-S3MLW</u>	<u>EA1-S3ML-N, EA1-S3MLW-N</u>
Description		128 x 64 pixel LCD display, five user defined keypad function buttons, and five user defined LED's	
Display			
• Type		3.1-inch STN monochrome LCD, graphical characters	
• Resolution		128 (W) x 64 (H) pixel	
• Color		2 colors (normal / inverse)	
• Viewing Area Size		2.789" (W) x 1.385" (H) [70.8 mm x 35.2 mm]	
• Active Area Size		2.670" (W) x 1.259" (H) [67.8 mm x 32.0 mm]	
• Contrast		Adjusted from the panel's built-in configuration setup menu	
• Viewing Angle		3, 9 o'clock axis → 45 degrees 6 o'clock axis → 45 degrees 12 o'clock axis → 30 degrees	
Backlight			
• Type		LED	
• Color		5 user defined colors: EA1-S3ML, EA1-S3ML-N - Red, Green, Amber, Lime, and Yellow EA1-S3MLW, EA1-S3MLW-N - White, Pink1, Pink2, Pink3 and Red	
• User Replaceable		No	
Touch Screen			
• Type		Analog touch panel, single touch*	N/A
• Operation		51 gram force [0.5 N] maximum	N/A
• Life		Minimum of 1,000,000 cycles	N/A
Features			
• User Memory		768 KB	
• Number of Screens		Up to 999 – limited by project memory usage	
• Beep (Internal)		Yes	
• Keypad Function Buttons		Five user defined function key buttons with the ability to customize the label. Minimum of 500,000 cycles	
• Keypad Function Button LEDs		Each function key button includes a red LED that can be user programmed.	
• Serial Communications		Built-in RJ12 serial communications port (RS-232). Optional serial communications port (RS-232, RS-485/422) when using the optional EA-MG-SP1 Serial Port with DC Power Adapter.	
• Expansion Connection		Yes – used with optional EA-MG-P1 DC Power Adapter (discontinued), and EA-MG-SP1 Serial Port with DC Power Adapter (discontinued).	
Screen Objects			
• Functional Devices		Pushbutton, Switch, Indicator Button, Indicator Light, Graphic Indicator Light, Numeric Display, Numeric Entry, Inc/Dec Value, Bar Graph, Bitmap Button, Static Bitmap, Dynamic Bitmap, Recipe Button, Static Text, Lookup Text, Dynamic Text, Scroll Text, Screen Change Pushbutton, Screen Selector, Adjust Contrast, Function, Key Configuration Object, Realtime Graph, Line Graph, Analog Meter	
• Static Shapes		Lines, Rectangles, Circles and Frames	
• Displayable Fonts		Fixed fonts: 4x6, 6x6, 6x6B, 6x8, 8x16, 8x32, 8x64, 16x16, 16x32, 16x64, 32x16, 32x32, 32x64, and Windows fonts	
*Note: The Touchscreen is designed to respond to a single touch. If it is touched at multiple points at the same time, an unexpected object may be activated.			
C-more 3-inch Micro panel specifications continued on next page.			

C-more Micro 3-inch EA1 Specifications

Specification	Model	3-inch STN Micro Panel Touch Screen	3-inch STN Micro Panel Non-Touch Screen
Part Number		EA1-S3ML, EA1-S3MLW	EA1-S3ML-N, EA1-S3MLW-N
Electrical			
• Input Voltage Range		5.0 VDC (4.75 – 5.25 VDC)	
• Input Power		Supplied through the panel's RJ12 serial communications port connection when used with any AutomationDirect PLC having an RJ12 communication port.	
• Power Consumption		1.05W (220mA @ 4.75 VDC)	
• Recommended Fuse		Type AGC fast acting glass fuse, 250 mA, 250 VAC, ADC p/n AGC-25 No fuse required when directly connected to a PLC or PC with recommended cable.	
• Maximum Inrush Current		1 A for 500 µs	
• Acceptable External Power Drop Duration		Maximum 1ms	
Environmental*			
• Operating Temperature		0 to 50 °C (32 to 122 °F) Maximum surrounding air temperature rating: 50 °C	
• Storage Temperature		-20 to +60 °C (-4 to +140 °F)	
• Humidity		5–95% RH (non-condensing)	
• Environmental Air		For use in Pollution Degree 2 Environment	
• Vibration		IEC60068-2-6 (Test Fc), 5-9 Hz: 3.5 mm amplitude, 9-150 Hz: 1.0G, sweeping, at a rate of 1 octave/min. (±10%), 10 sweep cycles per axis on each of 3 mutually perpendicular axes	
• Shock		IEC60068-2-27 (Test Ea), 15 G peak, 11ms duration, three shocks in each direction per axis, on 3 mutually perpendicular axes (total of 18 shocks)	
• Noise Immunity		NEMA ICS3-304 (EN61131-2) RFI, (145MHz, 440Mhz 10W @ 10cm) Impulse 1000V @ 1µS pulse EN61000-4-2 (ESD), EN61000-4-3 (RFI), EN61000-4-4 (FTB), EN61000-4-5 (Surge) N61000-4-6 (Conducted), EN61000-4-8 (Power frequency magnetic field immunity)	
• Enclosure		For use on a flat surface of Type 1, 4X enclosure (Indoor use only)	
• Agency Approvals		CE (EN61131-2), UL508, CUL Canadian C22.2 No. 142-M95, UL File E157382, CSA File 234884	
Physical			
• Dimensions		4.488" (W) x 3.228" (H) x 1.593" (D) [114.0 mm x 82.0 mm x 40.5 mm]	
• Enclosure Mounting Thickness Range		0.04" – 0.2" [1 – 5 mm]	
• Mounting Clip Screw Torque Range		21 – 28 oz-in [0.15 – 0.2 N·m]	
• Depth from bezel rear with options Module		2.295" [58.3 mm]	
• Weight		5.82 oz. (165 g)	



NOTE: The environmental specifications for the panels shown above are also applicable for the **C-more** 3" Micro accessories shown later in this section of the catalog.

Supported Protocols / Drivers
Serial - Panel port1
AutomationDirect Productivity Series
AutomationDirect CLICK
AutomationDirect Do-more / BRX*
AutomationDirect K-sequence
AutomationDirect DirectNET
AutomationDirect Modbus
Modicon Modbus RTU
Entivity Modbus RTU
Note: * BX-P-SER2-RJ12 is required



For a list of supported protocols and cabling options refer to the 3-inch **C-more** Micro Protocols and cabling chart starting on pagepage tCMM-12

C-more Micro 3-inch EA1 Series Programming Connections

C-more STN Micro Programming Connection

Using the **C-more** Micro Programming Software for project development, STN **C-more** Micro panels can be connected to a PC (personal computer) by using EA-MG-PGM-CBL, the USB-to-RS-232 cable assembly.

- Connect the USB programming cable (included) from a USB port type A on the PC to the USB type B port on the converter (included). Next connect the serial programming cable from the converter's RJ12 port to the panel's RJ12 serial port. The panel receives power from the USB port of the PC that it is connected to through the USB to RS-232 converter assembly.

USB to RS-232 Programming Cable Assembly



Part No. [EA-MG-PGM-CBL](#)

USB Connectivity

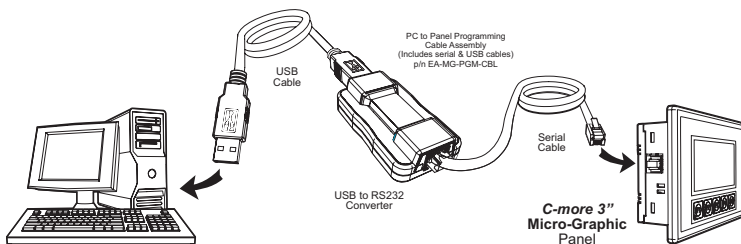

NOTE: EA1-T4CL does NOT use the EA-MG-PGM-CBL assembly. EA1-T4CL panel uses a standard USB A-to-B type cable such as USB-CBL-AB6.

USB to RS-232 Converter Specifications

Part Number	EA-MG-PGM-CBL
Hardware	
USB Interface	USB Specification Rev. 1.1 Connector: USB Type B jack to accept USB Type B cable plug
Serial Interface	RS-232 (EIA-232-E) Connector: RJ12 phone jack 6p to accept RJ12 cable plug
Baud Rate	115.2 kbps Maximum
Input Voltage	5 VDC (Supplied thru serial interface cable.)
Power Consumption	50 mA (Does not include power to panel and/or bezel.)
Accessory Cables (included)	
USB Cable	USB Type A plug to PC on one end, USB Type B plug to converter on other end, 0.30 m [1 foot] length (* Note)
Serial Cable	RJ12 phone plug connectors on both ends, 2.0 m [6.56 feet] length (* Note)
Physical	
Dimensions	2.559" (W) x 1.417" (H) x 0.886" (D) [65.0 mm x 36.0 mm x 22.5 mm]
Weight	1.06 oz. [30 g]
Environmental	See Micro panel specifications at the beginning of this catalog section.
* Note: Maximum cable length for either the USB or serial cable should not exceed 2.0 m [6.56 feet] in length.	

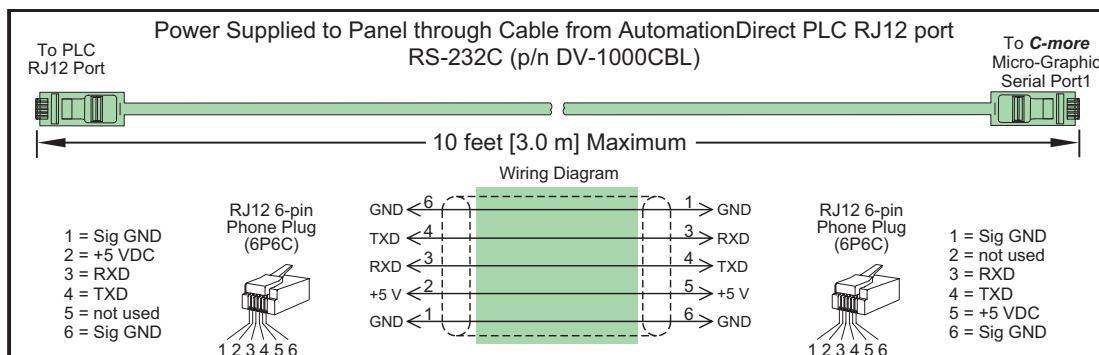

C-more Micro 3-inch EA1 Power Connection Wiring

Providing power to the touch panel

- The **C-more** 3-inch Micro panel is powered during programming from the PC through the USB to RS-232 Programming Cable Assembly, EA-MG-PGM-CBL.
- During operation, the **C-more** Micro panel can be powered from most AutomationDirect PLC's RJ12 serial communications port by using the [DV-1000CBL](#) communications cable.

3-inch Panel powered from AutomationDirect PLC via communications cable

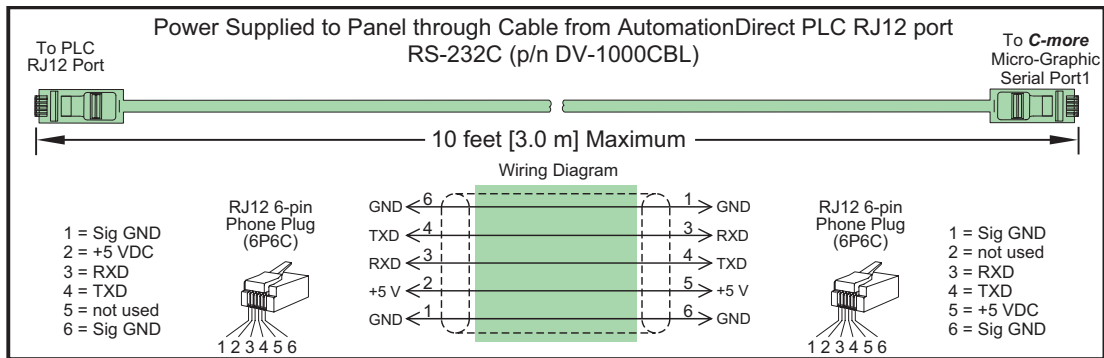

C-more Micro 3-inch EA1 PLC Connections

Cabling requirements

The following cables can be used when connecting the **C-more** 3-inch Micro panel's built-in RJ12 serial port (Port1) with the Productivity Series, Do-more/BRX*, CLICK, DL05, DL06, DL105, DL205, D3-350 and DL405 CPUs.

- **DV-1000CBL** — connects to Productivity Series, Do-more/BRX* CLICK, DL05, DL06, DL105, DL205, D3-350 and D4-450 phone jack.
- **D4-1000CBL** — connects to all DL405 CPU 15-pin ports.

A maximum cable length of 10 feet between the **C-more** Micro panel and the PLC is recommended when powering the panel from the PLC.

See the Communication Protocols & Cabling Charts in this catalog section for details on the selection of various controllers, protocols, and connectivity.

C-more 3-inch Micro Port 1 to CLICK PLC Port 2

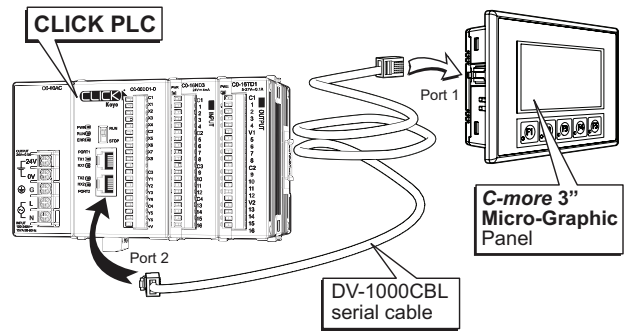

Drivers for your Controller

- AutomationDirect Productivity Series
- AutomationDirect Do-more/BRX*
- AutomationDirect CLICK (Modbus)
- **DirectLOGIC** K-sequence, **DirectLOGIC DirectNET**, **DirectLOGIC** Modbus (Koyo Addressing)
- Modbus RTU
- Allen Bradley DF1 Full Duplex, Allen Bradley DF1 Half Duplex, Allen Bradley PLC5 DF1, AB DH485
- Omron Host Link (C200 Adapter, C500) Omron FINS serial (CJ1, CS1)
- GE SNPX (90/30, 90/70, Micro 90, VersaMax Micro)
- Mitsubishi Melsec FX
- Siemens PPI
- Entivity Modbus RTU
- AutomationDirect GS Drives
- AutomationDirect SOLO Temperature Controllers
- Mitsubishi Q/QnA

* [BX-P-SER2-RJ12](#) is required

C-more 3-inch Micro Port 1 to DL06 PLC Port 1

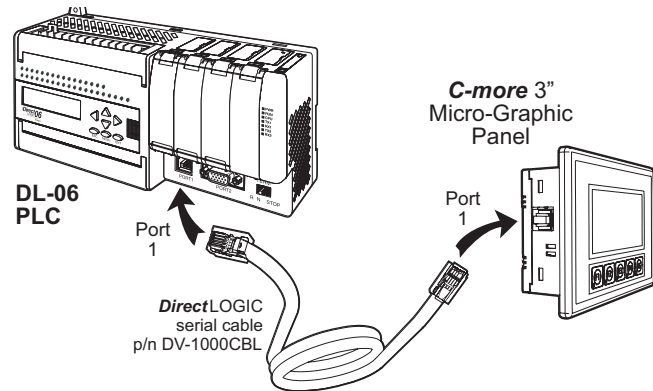

C-more 3-inch Micro Port 1 to DL205 PLC Port 1

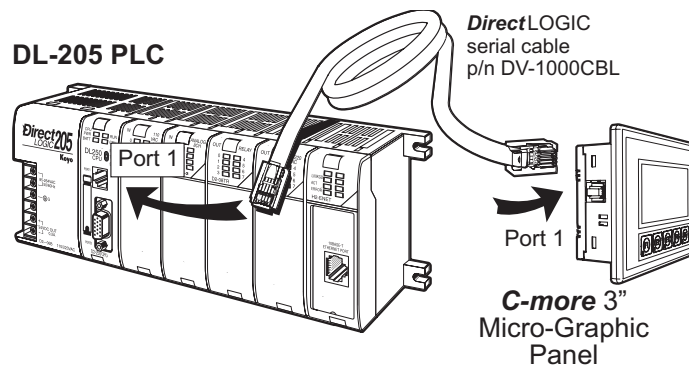

C-more Micro 3-inch EA1 Communication Protocols & Cabling Chart

Controller Compatibility & Connection Chart				
PLC			C-more 3-inch Micro Panel.	
Family	CPU	Port & Type	Panel to PLC Cabling Components Required for Specific Port and Protocol being used.	
			PLC Port Powered Powered with 5 VDC from the connected PLC's comm. port.	
			Using panel's RJ12 port 1	
			Protocol(s) Supported	Components & Network Type
CLICK	all versions	Port 1 RJ12 - 6 pin	AutomationDirect Modbus (CLICK)	DV-1000CBL RS-232
		Port 2 RJ12 - 6 pin		
	Analog CPU's	Port 3 Terminal block - 3-pin		N/A
Productivity Series	all versions	RS-232 RJ12 - 6 pin	AutomationDirect Productivity Serial	DV-1000CBL RS-232
		RS-485 Port Term block 3-pin		N/A
Do-more	all versions	Port 2 RJ12 - 6 pin	AutomationDirect Do-more Serial	DV-1000CBL RS-232
BRX	all versions	RS-232 POM module BX-P-SER2-RJ12	AutomationDirect Do-more Serial	DV-1000CBL RS-232
		RS-485 Port Term block 3-pin		N/A
DirectLOGIC DL05 (see D0-DCM under DL06)	all versions	Port 1 RJ12 - 6 pin	K-sequence, DirectNET , Modbus RTU	DV-1000CBL RS-232
		Port 2 RJ12 - 6 pin		
DirectLOGIC DL06	all versions	Port 1 RJ12 - 6 pin	K-sequence, DirectNET , Modbus RTU	DV-1000CBL RS-232
		Port 2 DB15HD (female)		DV-1000CBL + FA-15HD RS-232
	D0-DCM	Port 1 RJ12 - 6 pin	K-sequence, DirectNET , Modbus RTU	DV-1000CBL RS-232
		Port 2 DB15HD (female)		DV-1000CBL + FA-15HD RS-232
DirectLOGIC DL105	all versions	Port 1 RJ12 - 6 pin	K-sequence	DV-1000CBL RS-232

Note: See the C-more Micro Hardware User Manual, Chapter 6: PLC Communications, for wiring diagrams that the user can use to construct their own cables. Available for download at . PLC Compatibility & Connection Chart continued on next page.

C-more Micro 3-inch EA1 Communication Protocols & Cabling Chart (cont'd)

Controller Compatibility & Connection Chart				
PLC			C-more 3-inch Micro Panel.	
Family	CPU	Port & Type	Panel to PLC Cabling Components Required for Specific Port and Protocol being used.	
			PLC Port Powered Powered with 5 VDC from the connected PLC's comm. port.	
			Using panel's RJ12 port 1	
			Protocol(s) Supported	Components & Network Type
DirectLOGIC DL205	D2-230	Port 1 RJ12 - 6 pin	K-sequence	DV-1000CBL RS-232
	D2-240	Port 1 RJ12 - 6 pin	K-sequence	DV-1000CBL RS-232
		Port 2 RJ12 - 6 pin	K-sequence, DirectNET	
	D2-250-1	Port 1 RJ12 - 6 pin	K-sequence, DirectNET , Modbus RTU	DV-1000CBL RS-232
		Port 2 DB15HD (female)		DV-1000CBL + FA-15HD RS-232
	D2-260	Port 1 RJ12 - 6 pin	K-sequence, DirectNET , Modbus RTU	DV-1000CBL RS-232
		Port 2 DB15HD (female)		DV-1000CBL + FA-15HD RS-232
D2-DCM	Port 1 DB 25 pin (female)	K-sequence, DirectNET , Modbus RTU	See Note RS-232	
WINPLC	Port 1 RJ12 - 6 pin	Modbus RTU	DV-1000CBL RS-232	
DirectLOGIC DL305	D3-330 or D3-340	D3-232-DCU DB 25 pin (female)	N/A	
		D3-422-DCU DB 25 pin (female)	N/A	
	D3-340	Port 1 RJ11 - 4 pin	N/A	
		Port 2 RJ11 - 4 pin	N/A	
	D3-350	Port 1 RJ12 - 6 pin	K-sequence, DirectNET	DV-1000CBL RS-232
		Port 2 DB 25 pin (female)	N/A	
	D3-DCM D3-350 only	Port 1 DB 25 pin (female)	K-sequence, DirectNET , Modbus RTU	See Note RS-232

Note: See the C-more Micro Hardware User Manual, Chapter 6: PLC Communications, for wiring diagrams that the user can use to construct their own cables. Available for download at . PLC Compatibility & Connection Chart continued on next page.

C-more Micro 3-inch EA1 Communication Protocols & Cabling Chart (cont'd)

Controller Compatibility & Connection Chart				
PLC			C-more 3-inch Micro Panel.	
Family	CPU	Port & Type	Panel to PLC Cabling Components Required for Specific Port and Protocol being used.	
			PLC Port Powered Powered with 5 VDC from the connected PLC's comm. port. Using panel's RJ12 port 1	
			Protocol(s) Supported	Components & Network Type
DirectLOGIC DL405	D4-430	Port 0 DB 15 pin (female)	K-sequence	D4-1000CBL or DV-1000CBL & FA-CABKIT RS-232
		Port 1 DB 25 pin (female)	N/A	
	D4-440	Port 0 DB 15 pin (female)	K-sequence	D4-1000CBL or DV-1000CBL & FA-CABKIT RS-232
		Port 1 DB 25 pin (female)	N/A	
	D4-450 / D4-454	Port 0 DB 15 pin (female)	K-sequence	D4-1000CBL or DV-1000CBL & FA-CABKIT RS-232
		Port 1 DB 25 pin (female)	N/A	
		Port 2 RJ12 - 6 pin	K-sequence, DirectNET	DV-1000CBL RS-232
		Port 3 DB 25 pin (female)	N/A	
	D4-DCM	Port 1 DB 25 pin (female)	K-sequence, DirectNET , Modbus RTU	See Note RS-232
	SOLO	N/A	Data +/- terminals	N/A
GS Drives	N/A	RS-485 Interface	N/A	

Note: See the C-more Micro Hardware User Manual, Chapter 6: PLC Communications, for wiring diagrams that the user can use to construct their own cables. Available for download at . PLC Compatibility & Connection Chart continued on next page.

C-more Micro 3-inch EA1 Communication Protocols & Cabling Chart (cont'd)

Controller Compatibility & Connection Chart			
PLC			C-more 3-inch Micro Panel.
Family	CPU	Port & Type	Panel to PLC Cabling Components Required for Specific Port and Protocol being used.
			PLC Port Powered Powered with 5 VDC from the connected PLC's comm. port.
			Using panel's RJ12 port 1
			Protocol(s) Supported
Allen-Bradley MicroLogix	1000, 1100, 1200, 1400, 1500	8-pin mini-din port	N/A
		RJ45 8-pin phone plug	
Allen-Bradley SLC500	5/03, 5/04, 5/05	9-pin D-sub port	
	5/01, 5/02, 5/03	RJ45 8-pin phone plug	
Allen-Bradley ControlLogix	all	9-pin D-sub port	
Allen-Bradley CompactLogix	all	9-pin D-sub port	
Allen-Bradley FlexLogix	all	9-pin D-sub port	
Allen-Bradley PLC5	all	25-pin D-sub port	
		RJ45 8-pin phone plug	
GE	90/30	15-pin D-sub port	
	Micro 90, VersaMax Micro	RJ45 Port 1	
		15-pin D-sub port Port 2	
Mitsubishi	Melsec FX Series	25-pin D-sub port	
		8-pin mini-din port	
	Q / QnA	9-pin D-sub port	
		6-pin mini-din port	
Omron	C200 (Adapter), C500	25-pin D-sub port	
	CJ1, CS1, CQM1, CPM1, CPM2, C200	9-pin D-sub port	
Modicon	984 CPU, Quantum 113 CPU, AEG Modicon Micro Series 110 CPU	varies	
Siemens	S7-200 CPU	9-pin D-sub port 0 or 1	

Note: See the C-more Micro Hardware User Manual, Chapter 6: PLC Communications, for wiring diagrams that the user can use to construct their own cables. Available for download at . Available cables with descriptions shown on the next page.

C-more Micro 3-inch EA1 Communication Cables and Cable Kits

Cable Description	Cable Part Number	Price
Cables for direct connect to panel's serial Port1 (Panel powered from PLC's serial port.)		
Communication cable, 6-pin RJ12 to 6-pin RJ12, 2m/6.6ft cable length. For use with DV-1000 or C-more Micro panels and AutomationDirect PLCs with an RJ12 port.	<u>DV-1000CBL</u>	
Communication cable, 6-pin RJ12 to 15-pin male D-sub, shielded, 2m/6.6ft cable length. For use with DV-1000 or C-more Micro panels and any DL405 CPU.	<u>D4-1000CBL</u>	
Direct LOGIC DL06 connector, 15-pin D-sub HD15 male to RJ12 female. For use with DL06 CPUs and DL205 D2-250, D2-250-1, D2-260 and D2-262 CPUs.	<u>FA-15HD</u>	
Direct LOGIC universal cable kit, for use with all DirectLOGIC PLCs with RS-232 ports.	<u>FA-CABKIT</u>	
Communication cable, 6-pin RJ12 to 6-pin RJ11, 2m/6.6ft cable length. For use with any OP400 series OptiMate unit and a D3-340 CPU.	<u>OP-3CBL-1</u>	



[DV-1000CBL](#)



[D4-1000CBL](#)



[OP-3CBL-1](#)



[FA-15HD](#)



[FA-CABKIT](#)

C-more Micro 3-inch EA1 Panel Accessories

Clear Screen Overlay

Optional clear screen overlay used to protect **C-more** 3-inch Micro displays from minor scratches and wear. Package contains 5 clear screen overlays.

Part No. EA-MG-COV-CL

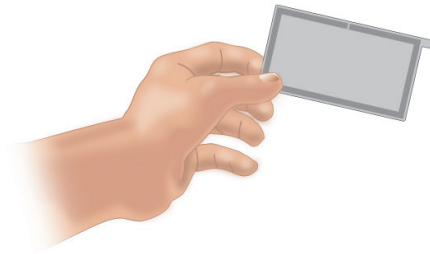

Dimensions

Units: inches [mm]

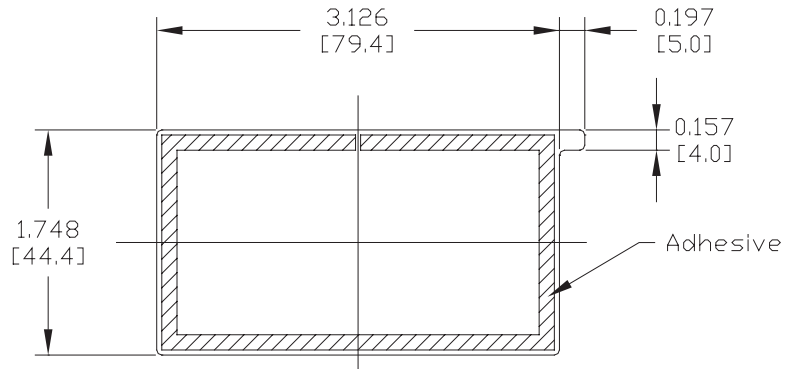

C-more Micro 3-inch EA1 Replacement Parts

The optional replacement parts can be used to replace damaged, worn or lost **C-more** 3-inch Micro panel components.

Replacement parts at a glance:

Part Number	Description	Price
<u>EA-MG-S3ML-BRK</u>	Panel mounting brackets, replacement. Package of 2. For use with C-more Micro 3in and EA3-T4CL HMIs.	
<u>EA-MG-BZ1-BRK</u>	Panel mounting brackets, replacement. Package of 2. For use with C-more Micro bezel EA-MG-BZ1.	
<u>EA-MG-BZ2-BRK</u>	Panel mounting brackets, replacement. Package of 8. For use with C-more Micro 4in and 6in panels, all 6in bezels, and 3in bezel EA-MG-BZ2.	
<u>EA-MG-DC-CON</u>	DC 3-terminal power connector, replacement. Package of 5. For use with all C-more Micro 4in, 6in, 8in and 10in panels, and power adapters EA-MG-P1 and EA-MG-SP1.	
<u>EA-MG-S3ML-GSK</u>	Panel mounting gasket, replacement. For use with C-more Micro EA1 series 3in HMIs.	
<u>EA-MG-BZ1-GSK</u>	Panel mounting gasket, replacement. For use with C-more Micro 3in bezel EA-MG-BZ1.	
<u>EA-MG-BZ2-GSK</u>	Panel mounting gasket, replacement. For use with C-more Micro 3in bezel EA-MG-BZ2.	
<u>EA-MG-S3ML-FKL</u>	Function key label insert, replacement. Package of 10. For use with C-more Micro 3in panels. (5) blank labels (5) landscape F1-F5 label included.	

Panel Mounting Clips
Part No. [EA-MG-S3ML-BRK](#)

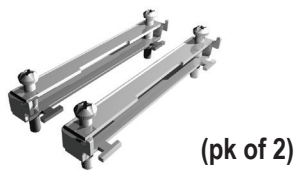

Keypad Bezel 1 Mounting Clips
Part No. [EA-MG-BZ1-BRK](#)

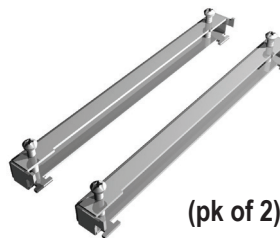

Keypad Bezel 2 Mounting Clips
Part No. [EA-MG-BZ2-BRK](#)

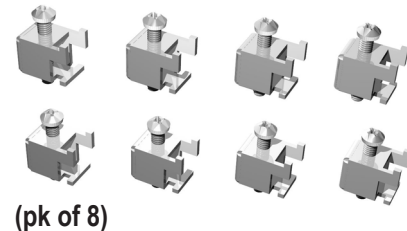

DC Power Connector
Part No. [EA-MG-DC-CON](#)

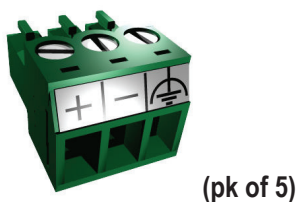

3-inch Panel Gasket
Part No. [EA-MG-S3ML-GSK](#)



3-inch Keypad Bezel 1 Gasket
Part No. [EA-MG-BZ1-GSK](#)



3-inch Keypad Bezel 2 Gasket
Part No. [EA-MG-BZ2-GSK](#)



3-inch Panel Function Keys Label Inserts
Part No. [EA-MG-S3ML-FKL](#)

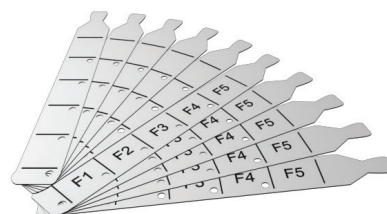

C-more Micro Programming Software

FREE software!

C-more Micro Programming Software can be downloaded at no charge or a CD version may be purchased by ordering **EA-MG-PGMSW**. The software requires a USB port or Ethernet connection* on your PC to connect to the **C-more** Micro panel. Software Help Files are included in the download. This software programs all the **C-more** Micro panels (does not program the **C-more** 6-inch through 15-inch touch panels).



Note: This software is used to program **C-more** Micro panels only.



Note: The Ethernet port is built in to **EA3-S3ML** and **EA3-T4CL**. **EA3-T6CL**, **EA3-T8CL** and **EA3-T10CL** require the optional **EA-ECOM** module for Ethernet.

Part Number	Panel Software / Firmware Version Required
EA3-S3ML-RN	4.30 or later
EA3-S3ML-R	
EA3-S3ML	4.20 or later
EA3-T4CL	
EA3-T6CL	3.6 or later
EA3-T8CL	3.5 or later
EA3-T10CL	

C-more Micro Programming Software is a spin-off of its powerful sibling **C-more**

Touch Panel. It offers very high end features designed to reduce your configuration time. Simply drag and drop the objects from the object list (right side of screen) onto the screen construction area. Then configure your PLC tags and click on the objects you wish to use. Use the built-in simulator to review your work on your PC before ever downloading your project! The time saving benefits of the **C-more** Micro configuration software could easily pay for the panel. Check out www.CmoreMicro.com to download a free version.

Thumbnail project preview pane

Helps keep track of multi-screen projects.

Built-in project simulator

- Runs your project on your PC
- Test all of your screens before downloading
- Time savings pays for the panel
- Simulate function keys and keypad bezel

Built-in user object/ screen libraries

Save time by re-using your custom objects and screens.

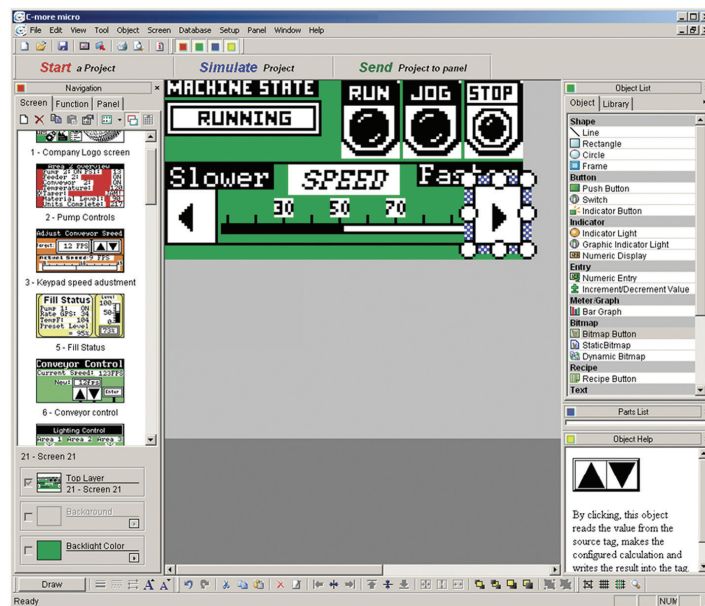

Scrolling object selection window

Lets you find the object you want fast. Just drag and drop it on the screen.

PC requirements

Following are the minimum system requirements for running **C-more** Micro Programming Software, **EA-MG-PGMSW**, on a PC:

- Windows® Operating System (See automationdirect.com for specific operating system requirements.)
- 150 MB free hard-disk space
- CD-ROM or DVD drive for installing software from the CD, or internet access to download free programming software
- USB port to use with the correct Programming Cable Assembly for project transfer from the programming software to the panel

Scrolling help window

Gives you helpful information on each object