



CWC Series Miniature Contactors

Features

- Rated up to 15hp @ 460V
- Direct mounting to the WEG RW17D overload relay
- Frame size is identical for AC and DC coil contactors up to 16A (CWC07-16).
- CWC025 frame available with AC coil only
- Heavy-duty operation
- Tool-free DIN-rail mounting
- WEG 18-month warranty
- Snap-on accessories
- DC coil low consumption: 1.7–2.7 W
- DC coil standard consumption: 2.6–3.7 W

The CWC series mini contactors are a complete solution for switching and controlling motors. The CWC's compact dimensions for its IEC current rating, up to 22A, AC-3 utilization category, allows it to take up less space inside electrical enclosures while still maintaining a powerful 15hp @ 460V. Dimensions of the 7A to 16A contactors are the same for both AC or DC coil voltages, making the panel design and assembly easier. DC models feature low consumption coils allowing the CWC to be operated directly from a PLC without interface relays.

More Horsepower in a Smaller Frame



Agency Approvals/Certifications

- cULus listed (File No. E202315/E189202)
- CE marked low voltage directive 2006/95/EC

Standards

- IEC/EN 60947-1
- UL 508
- CSA-C22.2 No. 14





CWC Series Miniature Contactors

Overview

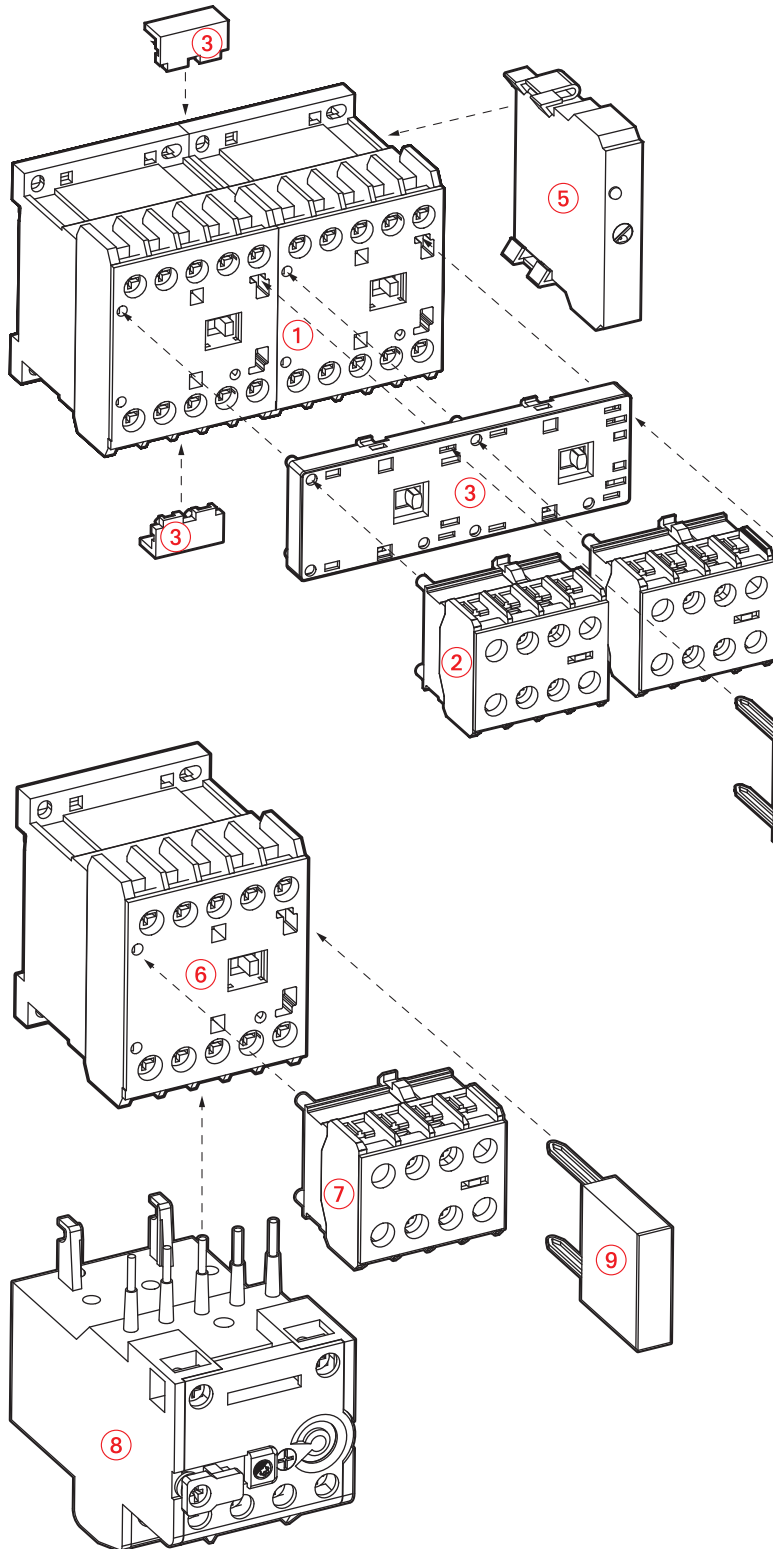

- ① **Mini contactors**
– CWC07...16
- ② **Auxiliary frontal contact block**
– BFC0, BFC4
- ③ **Mechanical interlock block or latch block with connecting clips included**
– BIC0 (for use with CWC07...16)
– RMC0 (for use with CWC07...16)
- ④ **Surge suppressor blocks**
– RCC0, VRC0, DIC0
- ⑤ **Electronic Timers**
– TETC0 (for use with CWC07...25)

- ⑥ **Mini contactor**
– CWC025
- ⑦ **Auxiliary frontal contact block**
– BFC025
- ⑧ **Overload relay**
– RW17-2D (for use with CWC025)
– RW17-1D (for use with CWC07...16)
- ⑨ **Surge suppressor blocks**
– RCC0, VRC0



CWC Series Miniature Contactors Configuration

Three-Pole Contactors

Three-Pole Mini Contactors with AC Coil (IEC/EN – 60947-1)													
Part Number	Price	Current Rating		Maximum Rated Operational Power kW [hp]						Number of Contacts			Coil Voltage and Frequency
		AC-3 (A)	AC-1 (A)	220V 230V	380V	400V 415V	440V	500V	660V 690V	Main	Built-in Aux Contacts		
											N.O.	N.C.	
CWC07-10-30V04		7	18	1.5 [2]	3 [4]	3 [4]	3.7 [5]	3.7 [5]	3 [4]	3	1	–	24VAC 60Hz
CWC07-10-30V18										3	1	–	120VAC 60Hz/110VAC 50Hz
CWC07-10-30V24										3	1	–	208-240 VAC 60Hz
CWC07-10-30V47										3	1	–	480VAC 60Hz/400-415 VAC 50Hz
CWC07-01-30V04										3	–	1	24VAC 60Hz
CWC07-01-30V18										3	–	1	120VAC 60Hz/110VAC 50Hz
CWC07-01-30V24										3	–	1	208-240 VAC 60Hz
CWC07-01-30V47										3	–	1	480VAC 60Hz/400-415 VAC 50Hz
CWC09-10-30V04		9	20	2.2 [3]	4 [5.4]	4 [5.4]	4.5 [6]	4.5 [6]	4 [5.4]	3	1	–	24VAC 60Hz
CWC09-10-30V18										3	1	–	120VAC 60Hz/110VAC 50Hz
CWC09-10-30V24										3	1	–	208-240 VAC 60Hz
CWC09-10-30V47										3	1	–	480VAC 60Hz/400-415 VAC 50Hz
CWC09-01-30V04										3	–	1	24VAC 60Hz
CWC09-01-30V18										3	–	1	120VAC 60Hz/110VAC 50Hz
CWC09-01-30V24										3	–	1	208-240 VAC 60Hz
CWC09-01-30V47										3	–	1	480VAC 60Hz/400-415 VAC 50Hz
CWC012-10-30V04		12	22	3 [4]	5.5 [7.5]	5.5 [7.5]	5.5 [7.5]	5.5 [7.5]	5.5 [7.5]	3	1	–	24VAC 60Hz
CWC012-10-30V18										3	1	–	120VAC 60Hz/110VAC 50Hz
CWC012-10-30V24										3	1	–	208-240 VAC 60Hz
CWC012-10-30V47										3	1	–	480VAC 60Hz/400-415 VAC 50Hz
CWC012-01-30V04										3	–	1	24VAC 60Hz
CWC012-01-30V18										3	–	1	120VAC 60Hz/110VAC 50Hz
CWC012-01-30V24										3	–	1	208-240 VAC 60Hz
CWC012-01-30V47										3	–	1	480VAC 60Hz/400-415 VAC 50Hz
CWC016-10-30V04		16	22	4 [5.4]	7.5 [10]	7.5 [10]	7.5 [10]	7.5 [10]	7.5 [10]	3	1	–	24VAC 60Hz
CWC016-10-30V18										3	1	–	120VAC 60Hz/110VAC 50Hz
CWC016-10-30V24										3	1	–	208-240 VAC 60Hz
CWC016-10-30V47										3	1	–	480VAC 60Hz/400-415 VAC 50Hz
CWC016-01-30V04										3	–	1	24VAC 60Hz
CWC016-01-30V18										3	–	1	120VAC 60Hz/110VAC 50Hz
CWC016-01-30V24										3	–	1	208-240 VAC 60Hz
CWC016-01-30V47										3	–	1	480VAC 60Hz/400-415 VAC 50Hz
CWC025-00-30V04		22	32	5.5 [7.5]	11 [15]	11 [15]	11 [15]	11 [15]	11 [15]	3	–	–	24VAC 60Hz
CWC025-00-30V18										3	–	–	120VAC 60Hz/110VAC 50Hz
CWC025-00-30V24										3	–	–	208-240 VAC 60Hz
CWC025-00-30V47										3	–	–	480VAC 60Hz/400-415 VAC 50Hz
Three-Pole Mini Contactors with DC Coil (IEC/EN – 60947-1)													
CWC07-10-30L02		7	18	1.5 [2]	3 [4]	3 [4]	3.7 [5]	3.7 [5]	3 [4]	3	1	–	12VDC low consumption
CWC07-10-30L03										3	1	–	24VDC low consumption
CWC07-01-30L02										3	–	1	12VDC low consumption
CWC07-01-30L03										3	–	1	24VDC low consumption
CWC09-10-30L02		9	20	2.2 [3]	4 [5.4]	4 [5.4]	4.5 [6]	4.5 [6]	4 [5.4]	3	1	–	12VDC low consumption
CWC09-10-30L03										3	1	–	24VDC low consumption
CWC09-01-30L02										3	–	1	12VDC low consumption
CWC09-01-30L03										3	–	1	24VDC low consumption
CWC012-10-30L02		12	22	3 [4]	5.5 [7.5]	5.5 [7.5]	5.5 [7.5]	5.5 [7.5]	5.5 [7.5]	3	1	–	12VDC low consumption
CWC012-10-30L03										3	1	–	24VDC low consumption
CWC012-01-30L02										3	–	1	12VDC low consumption
CWC012-01-30L03										3	–	1	24VDC low consumption
CWC016-10-30L02		16	22	4 [5.4]	7.5 [10]	7.5 [10]	7.5 [10]	7.5 [10]	7.5 [10]	3	1	–	12VDC low consumption
CWC016-10-30L03										3	1	–	24VDC low consumption
CWC016-01-30L02										3	–	1	12VDC low consumption
CWC016-01-30L03										3	–	1	24VDC low consumption

Note: Low consumption 12VDC and 24VDC contactors can only use 2-pole auxiliary contact blocks.



CWC Series Miniature Contactors Configuration

Four-Pole Contactors

Four-Pole Mini Contactors with AC Coil (IEC/EN – 60947-1)												
Part Number	Price	Current Rating		Maximum Rated Operational Power KW [hp]						Number of Main Contacts		Coil Voltage and Frequency
		AC-3 (A)	AC-1 (A)	230V 230V	380V	400V 415V	440V	500V	660V 690V	NO	NC	
CWC07-00-40V04		7	18	1.5 [2]	3 [4]	3 [4]	3.7 [5]	3.7 [5]	3 [4]	4	–	24VAC 60Hz
CWC07-00-40V18	4									–	120VAC 60Hz/110VAC 50Hz	
CWC07-00-40V24	4									–	208-240 VAC 60Hz	
CWC07-00-40V47	4									–	480VAC 60Hz/400-415 VAC 50Hz	
CWC07-00-22V04	2									2	24VAC 60Hz	
CWC07-00-22V18	2									2	120VAC 60Hz/110VAC 50Hz	
CWC07-00-22V24	2									2	208-240 VAC 60Hz	
CWC07-00-22V47	2									2	480VAC 60Hz/400-415 VAC 50Hz	
CWC09-00-40V04		9	20	2.2 [3]	4 [5.4]	4 [5.4]	4.5 [6]	4.5 [6]	4 [5.4]	4	–	24VAC 60Hz
CWC09-00-40V18	4									–	120VAC 60Hz/110VAC 50Hz	
CWC09-00-40V24	4									–	208-240 VAC 60Hz	
CWC09-00-40V47	4									–	480VAC 60Hz/400-415 VAC 50Hz	
CWC09-00-22V04	2									2	24VAC 60Hz	
CWC09-00-22V18	2									2	120VAC 60Hz/110VAC 50Hz	
CWC09-00-22V24	2									2	208-240 VAC 60Hz	
CWC09-00-22V47	2									2	480VAC 60Hz/400-415 VAC 50Hz	
CWC016-00-40V04		16	22	4 [5.4]	7.5 [10]	7.5 [10]	7.5 [10]	7.5 [10]	7.5 [10]	4	–	24VAC 60Hz
CWC016-00-40V18	4									–	120VAC 60Hz/110VAC 50Hz	
CWC016-00-40V24	4									–	208-240 VAC 60Hz	
CWC016-00-40V47	4									–	480VAC 60Hz/400-415 VAC 50Hz	
CWC016-00-22V04	2									2	24VAC 60Hz	
CWC016-00-22V18	2									2	120VAC 60Hz/110VAC 50Hz	
CWC016-00-22V24	2									2	208-240 VAC 60Hz	
CWC016-00-22V47	2									2	480VAC 60Hz/400-415 VAC 50Hz	
Four-Pole Mini Contactors with DC Coil (IEC/EN – 60947-1)												
CWC07-00-40L02		7	18	1.5 [2]	3 [4]	3 [4]	3.7 [5]	3.7 [5]	3 [4]	4	–	12VDC Low consumption
CWC07-00-40L03	4									–	24VDC Low consumption	
CWC07-00-22R02	2									2	12VDC Standard consumption	
CWC07-00-22R03	2									2	24VDC Standard consumption	
CWC09-00-40L02		9	20	2.2 [3]	4 [5.4]	4 [5.4]	4.5 [6]	4.5 [6]	4 [5.4]	4	–	12VDC Low consumption
CWC09-00-40L03	4									–	24VDC Low consumption	
CWC09-00-22R02	2									2	12VDC Standard consumption	
CWC09-00-22R03	2									2	24VDC Standard consumption	
CWC016-00-40L02		16	22	4 [5.4]	7.5 [10]	7.5 [10]	7.5 [10]	7.5 [10]	7.5 [10]	4	–	12VDC Low consumption
CWC016-00-40L03	4									–	24VDC Low consumption	
CWC016-00-22R02	2									2	12VDC Standard consumption	
CWC016-00-22R03	2									2	24VDC Standard consumption	

Note: Low consumption 12VDC and 24VDC contactors can only use 2-pole auxiliary contact blocks.

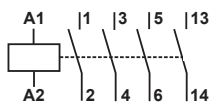

CWC07-10...CWC016-10

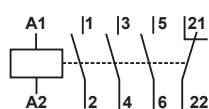

CWC07-01...CWC016-01

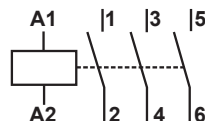

CWC025-00

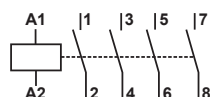

CWC07-00-40...CWC016-00-40

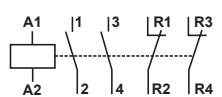

CWC07-00-22...CWC016-00-22



CWC Series Miniature Contactors Configuration

How to Identify Your Part Number

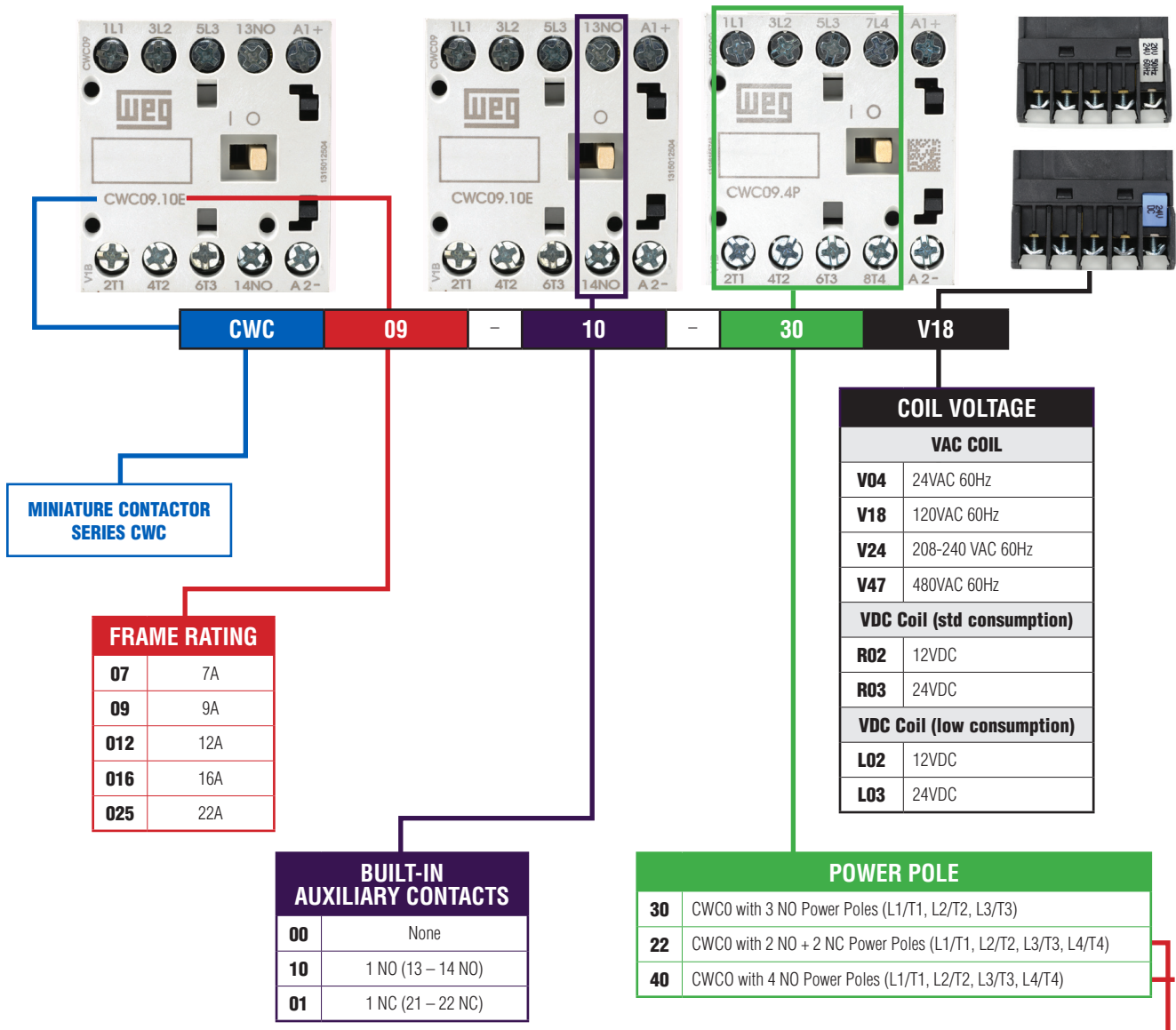

Note: For reference only. Not intended to build a part number.

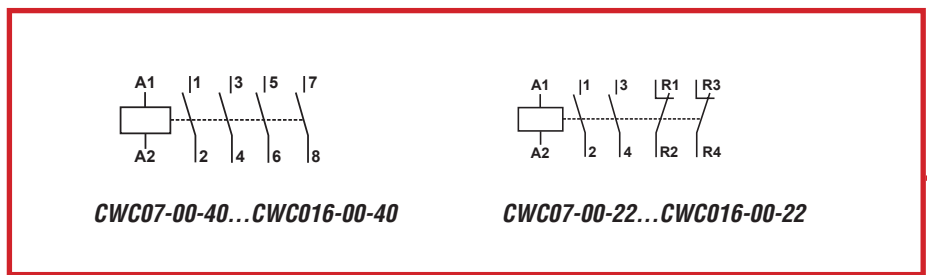



CWC Series Miniature Contactors

Technical Characteristics

CWC Miniature Contactors General Technical Characteristics						
Contactor part numbers		CWC07	CWC09	CWC012	CWC016	CWC025
Standards		IEC/EN 60947-1, IEC/EN 60947-4, DIN VDE 0660(102), UL508				
Rated insulation voltage U_i (pollution degree 3)	IEC/EN 60947-4-1, VDE 0660			690		
	UL, CSA			600		
Rated impulse withstand voltage U_{imp}	(IEC/EN 60947-1)			4		
Rated operational frequency (contact switchable)				25–400		
Mechanical lifespan	AC coil Ops x 10^6				10	3
	DC coil Ops x 10^6				12	–
Electrical lifespan	I_e AC-3 Ops x 10^6	1.4	1.3	1.2	1.1	0.6
Degree of protection (VDE 0160)	Main circuits	IP20				
	Control circuits and auxiliary contacts	IP20				
Mounting		Screw or DIN-rail 35mm (EN 50022)				
Coil terminals		2				
Vibration resistance	Contactor open (g)	2				
	Contactor closed (g)	4				
Mechanical shock resistance ($\frac{1}{2}$ sinusoid = 11ms)	Contactor open (g)	6				
	Contactor closed (g)	10				
Ambient temperature	Operation	-25 to +55°C [-13 to +131°F]				
	Storage	-55 to +80°C [-67 to +176°F]				
Maximum operating altitude (without derating)		up to 3000m [9842.5 ft]				
Altitude derating	0.72 x rated hp	3000 – 4000 m [9842.5 – 13123.4 ft]				
	0.60 x rated hp	4000 – 5000 m [13123.4 – 16404.2 ft]				

UL508 and IEC/EN Specifications						
Contactor part numbers		CWC07	CWC09	CWC012	CWC016	CWC025
Standards		UL508/CSA Ratings				
Rated operating voltage	(V)	600				
UL general purpose rating	(A)	18	20	22	22	30
Switching motor loads full voltage		(Hz) 50/60				
1-phase	115V (A)	7.2	7.2	9.8	16	20
	230V (A)	6.9	8	12	12	17
	115V (hp)	1/3	1/3	1/2	1	1-1/2
	230V (hp)	3/4	1	2	2	3
3-phase	208V (A)	6.9	7.8	11	11	17.5
	230V (A)	6	9.6	9.6	15.2	22
	460V (A)	7.6	7.6	11	14	21
	575V (A)	6.1	9	9	11	17
	208V (hp)	1-1/2	2	3	3	5
	230V (hp)	1-1/2	3	3	5	7-1/2
	460V (hp)	5	5	7-1/2	10	15
	575V (hp)	5	7-1/2	7-1/2	10	15
Short circuit current rating (SCCR)	600V (kA)	5	5	5	5	5
Standards		IEC Ratings (IEC/EN 60947)				
Rated operating voltage	(V)	690				
Rated thermal current I_{th}	AC-1 ($\leq 55^\circ\text{C}$)	18	20	22	22	32
	AC-3 ($U_e \leq 440\text{V}$)	7	9	12	16	22
Switching motor loads		(Hz) 50/60				
3-phase	220-240 V (A)	7	9	12	16	22
	380-400 V (A)	7	9	12	16	22
	415-440 V (A)	7	9	12	16	22
	500V (A)	6.2	7.5	8.8	13	16
	660-690 V (A)	4.5	5.5	6.6	10	13
	220-240 V (kW)	1.5	2.2	3	3.7	5.5
	380-400 V (kW)	3	3.7	5.5	7.5	11
	415-440 V (kW)	3.7	4.5	5.5	7.5	11
	500V (kW)	3.7	4.5	5.5	7.5	11
	660-690 V (kW)	3	3.7	5.5	7.5	11



CWC Series Miniature Contactors

Technical Characteristics

Control Circuit - Alternating Current (AC)							
Contactor part numbers			CWC07	CWC09	CWC012	CWC016	CWC025
Rated insulation voltage U_i <i>(pollution degree 3)</i>	IEC/EN 60947-4-1, VDE 0660	(V)	1000				
	UL, CSA	(V)	600				
Coils rated voltage	50Hz	(V)	10-550				
	60Hz	(V)	12-660				
	50/60 Hz	(V)	12-660				
Coil operating limits							
Coil 60Hz	Pick up percent of voltage	(%)	40-76				
	Drop out percent of voltage	(%)	25-65				
Coil 50/60 Hz	Pick up percent of voltage	(%)	50-80				
	Drop out percent of voltage	(%)	20-60				
Average consumption							
Coil 60Hz	Magnetic circuit closed	(VA)	2.5-3.5			10.8-13.2	
	Power factor	(cos φ)	0.28			0.32	
	Power dissipation per pole	(W)	2.6			-	
	Magnetic circuit closing	(VA)	35			72	
	Power factor	(cos φ)	0.85			0.93	
Coil 50/60 Hz	Magnetic circuit closed	(VA)	2-3			4.56-5.8	
	Magnetic circuit closing	(VA)	30			58	
Average time	Closing NO contacts	(ms)	8-20			13-16	
	Opening NO contacts	(ms)	6-13			13.5-17	

Control Circuit - Direct Current (DC)					
Contactor part numbers			CWC07, CWC09, CWC012, CWC016		
Coil type			Standard	Low consumption	4P (2P/2R)
Rated insulation voltage U_i <i>(pollution degree 3)</i>	IEC/EN 60947-4-1, VDE 0660	(V)	1000		
	UL, CSA	(V)	600		
Standard voltages			(V) 12-440		
Coil operating limits					
Coil operating limits	Pick up percent of voltage	(%)	40-70		
	Drop out percent of voltage	(%)	15-40		
Power consumption					
Power consumption	Magnetic circuit closed	(W)	2.6-3.7	1.7-2.7	2.9-4
	Magnetic circuit closing	(W)	2.6-3.7	1.7-2.7	2.9-4
Operation time	Closing NO contacts	(ms)	35-45		
	Opening NO contacts	(ms)	7-12		



CWC Series Miniature Contactors

Technical Characteristics

CWC Series Miniature Contactors Power Circuit							
Contactor part numbers			CWC07	CWC09	CWC012	CWC016	CWC025
Rated operational current I_e	AC-3 ($U_e \leq 440V$)	(A)	7	9	12	16	22
	AC-4 ($U_e \leq 440V$)	(A)	2.8	3.5	4.5	5	9
	AC-1 ($\theta \leq 55^\circ C, U_e \leq 690V$)	(A)	18	20	22	22	32
Rated operational voltage U_e	IEC/EN 60947-4-1, VDE 0660	(V)	690				
	UL, CSA ¹	(V)	600				
Rated thermal current I_{th} ($\theta \leq 55^\circ C$)		(A)	18	20	22	22	32
Making capacity - IEC/EN 60947		(A)	70	90	120	160	250
Breaking capacity IEC/EN 60947	($U_e \leq 400V$)	(A)	50	72	96	128	200
	($U_e = 500V$)	(A)	50	72	96	128	200
	($U_e = 690V$)	(A)	35	54	72	96	150
Short-time current (no current flowing during recovery time of 10 min and $\theta \leq 40^\circ C$)	1 sec	(A)	250	250	250	250	–
	5 sec	(A)	125	125	125	125	–
	10 sec	(A)	95	95	95	95	–
	30 sec	(A)	70	70	70	70	–
	1 min	(A)	50	50	50	50	–
	3 min	(A)	40	40	40	40	–
Protection against short-circuits with fuses (IEC gL/gG)² or UL Class CC	@ 600V - UL/CSA ¹	(kA)	5				
	Coordination type 1	(A)	35	35	35	35	50
	Coordination type 2	(A)	20	20	25	25	35
Average impedance per pole		(m Ω)	6	6	5	5	6
Average power dissipation per pole	AC-1	(W)	1.9	2.4	2.4	2.4	6.1
	AC-3	(W)	0.3	0.5	0.7	1.3	3.8
Utilization Category AC-3							
Rated operational current I_e ($\theta \leq 55^\circ C$)	($U_e \leq 440V$)	(A)	7	9	12	16	22
	($U_e \leq 500V$)	(A)	6.2	7.5	8.8	13	16
	($U_e \leq 690V$)	(A)	4.5	5.5	6.6	10	13
	($U_e \leq 1000V$)	(A)	Not available				
Rated operational power	220/230 V	(kW)	1.5	2.2	3	3.7	5.5
		(hp)	2	3	4	5	7.5
	380V	(kW)	3	3.7	5.5	7.5	11
		(hp)	4	5	7.5	10	15
	400/415 V	(kW)	3	3.7	5.5	7.5	11
		(hp)	4	5	7.5	10	15
	440V	(kW)	3.7	4.5	5.5	7.5	11
		(hp)	5	6	7.5	10	15
	500V	(kW)	3.7	4.5	5.5	7.5	11
		(hp)	5	6	7.5	10	15
	660/690 V	(kW)	3	3.7	5.5	7.5	11
		(hp)	4	5	7.5	10	15
Maximum electrical operations per hour	600 ops/hr	(%)	100	100	100	100	100
	1200 ops/hr	(%)	75	75	75	75	75
	3000 ops/hr	(%)	50	50	50	50	50
Utilization Category AC-4							
Rated operational current I_e AC-4 ($U_e \leq 440 V$)		(A)	2.8	3.5	4.5	5	9
Rated operational power (200,000 operations)	220/230 V	(kW)	0.55	0.75	0.75	1.1	2.2
		(hp)	0.7	1	1	1.5	2.9
	380/400 V	(kW)	1.1	1.1	1.8	2.2	4
		(hp)	1.5	1.5	2.4	2.9	5.4
	415V	(kW)	1.1	1.5	2.2	2.2	4.5
		(hp)	1.5	2	2.9	2.9	6
	440V	(kW)	1.1	1.5	2.2	2.2	4.5
		(hp)	1.5	2	2.9	2.9	6
	500V	(kW)	1.1	1.5	2.2	2.2	4.5
		(hp)	1.5	2	2.9	2.9	6
	660/690 V	(kW)	1.1	1.5	2.2	2.2	4.5
		(hp)	1.5	2	2.9	2.9	6

¹Note: Specifications only valid for 50/60 Hz three-phase, 4 poles WEG standard motors.

²Note: Not sold by Automation Direct.



CWC Series Miniature Contactors

Technical Characteristics

Built-In Auxiliary Contacts Technical Characteristics			
Standards	IEC 60947-5-1, IEC 60947-4-1		
Rated insulation voltage U_i (pollution degree 3)	IEC, VDE 0660	(V)	690
	UL, CSA	(V)	600
Rated operational voltage U_e	IEC, VDE 0660	(V)	690
	UL, CSA	(V)	600
Rated thermal current I_{th} ($\theta \leq 55^\circ\text{C}$)		(A)	10
Rated operational current I_e			
AC-15 (IEC 60947-5-1)	$U_e \leq 240\text{V}$	(A)	10
	380–400 V	(A)	6
	415–440 V	(A)	6
	500V	(A)	4
	660–690 V	(A)	2
		UL/CSA	
DC-13 (IEC 60947-5-1)	24V	(A)	6
	60V	(A)	2
	110V	(A)	1
	220–240 V	(A)	0.3
	UL/CSA		Q600
Making capacity (rms)	U_e 400 V 50/60 Hz - AC-15	(A)	10 x I_e (AC-15)
Breaking capacity (rms)	U_e 400 V 50/60 Hz - AC-15	(A)	10 x I_e (AC-15)
Maximum IEC fuse class gL/gG without welding (short-circuit protection) gL/gG		(A)	10
Control circuit reliability		(V/mA)	17 / 5
Electrical endurance	(millions operations)		1
Mechanical endurance	(millions operations)		10



CWC Series Miniature Contactors

Electrical Durability

AC-3 ($U_e \leq 440\text{VAC}$)

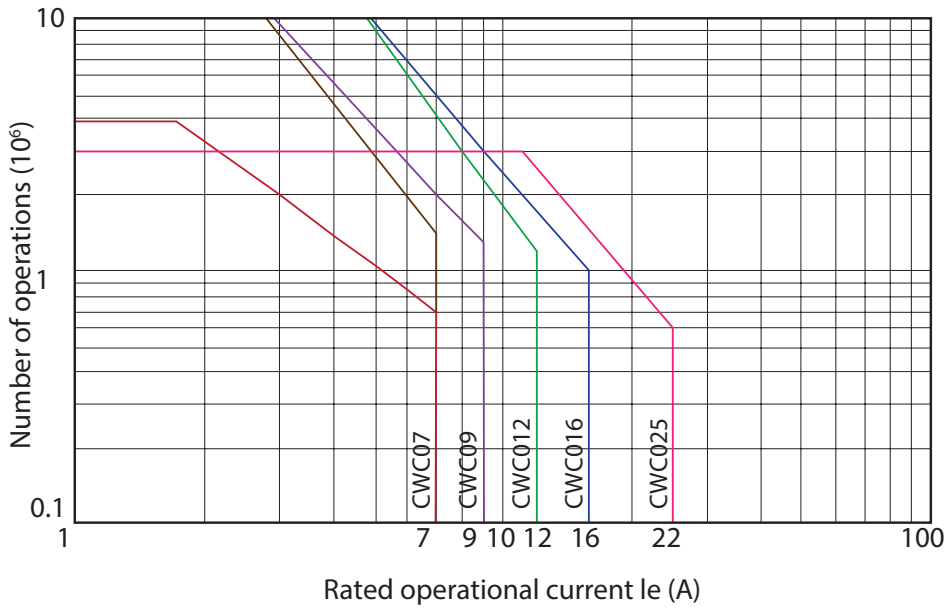

AC-4 ($U_e \leq 440\text{VAC}$)

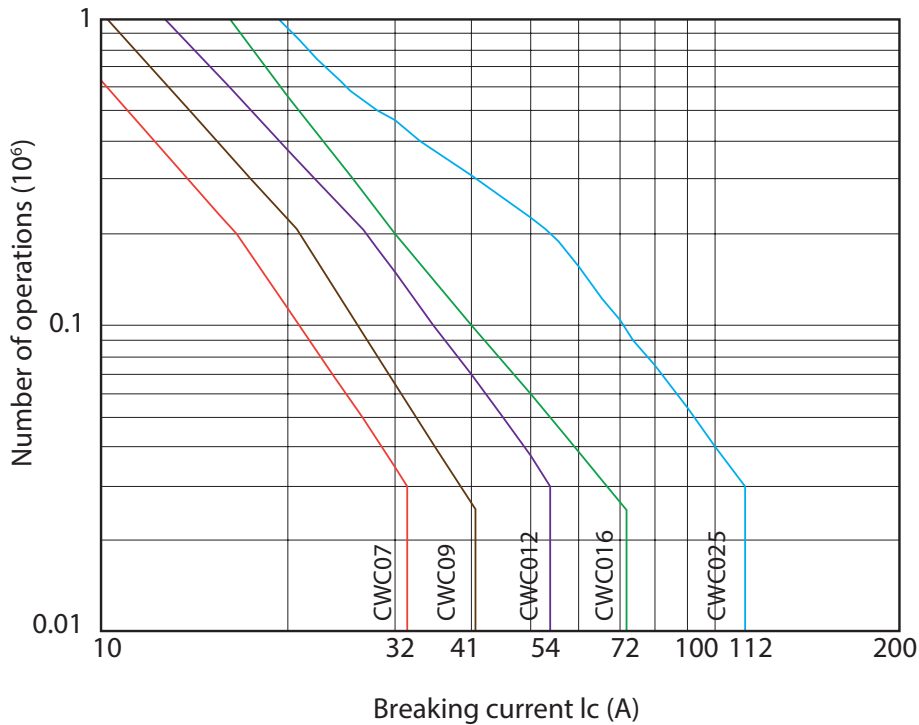



CWC Series Miniature Contactors

Dimensions

Dimensions mm [inches]

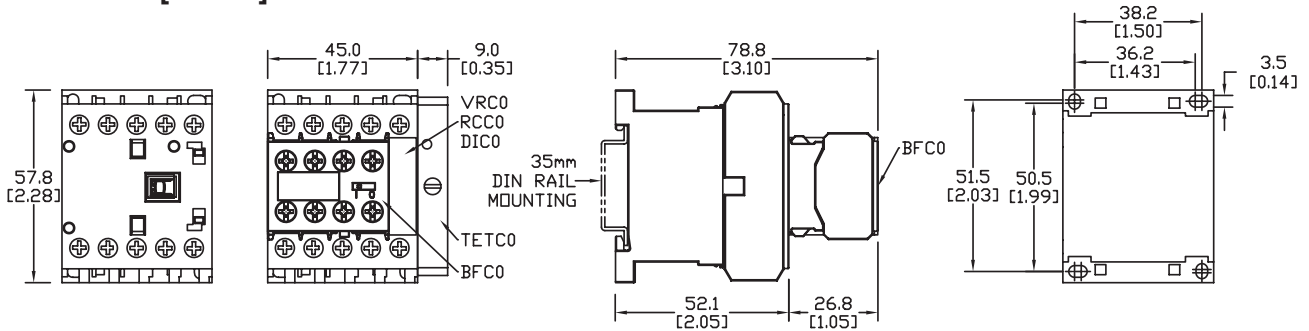

CWC07, CWC09, CWC012, CWC016 + VRCO/RCCO/DICO

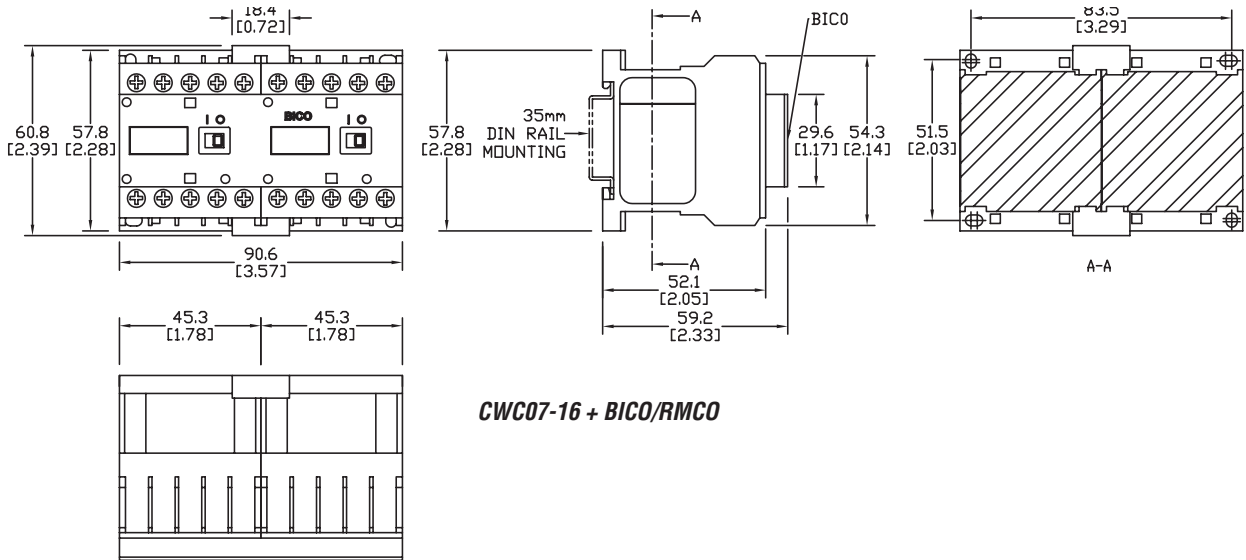

CWC07-16 + BICO/RMCO

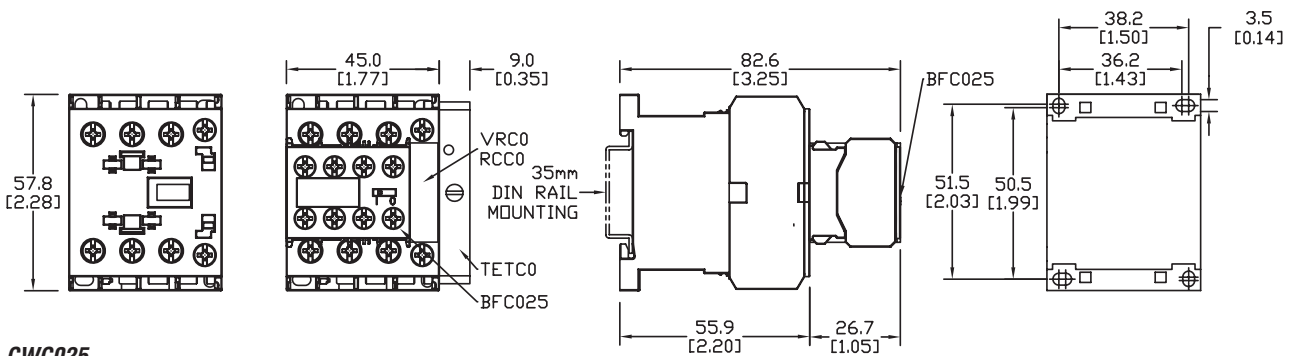

CWC025

Mounting position for CWC miniature contactors

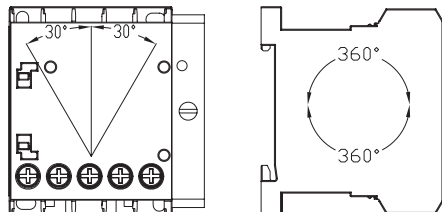



CWC Series Miniature Contactors Accessories

Front Mounting Auxiliary Contact Blocks

Auxiliary Contact Blocks											
Use With	2 Maximum # of Contacts		Terminal Markings	Part Number	Price	Use With	2 Maximum # of Contacts		Terminal Markings	Part Number	Price
	Auxiliary Contacts	N.O.					N.C.	Auxiliary Contacts			
Three-Pole Contactors (CWC07, CWC09, CWC012, CWC016)	2	0		BFC0-20*		Four-Pole Contactors (CWC07, CWC09, CWC016)	2	0		BFC4-20*	
	1	1		BFC0-11*			1	1		BFC4-11*	
	0	2		BFC0-02*			0	2		BFC4-02*	
	4 Maximum # of Contacts						4 Maximum # of Contacts				
	4	0		BFC0-40			4	0		BFC4-40	
	2	2		BFC0-22			2	2		BFC4-22	
	0	4		BFC0-04			0	4		BFC4-04	
	3	1		BFC0-31			3	1		BFC4-31	
	1	3		BFC0-13			1	3		BFC4-13	
	Three-Pole Contactors CWC025	2 Maximum # of Contacts					*Note: Low consumption 12VDC and 24VDC contactors can only use 2-pole auxiliary contact blocks				
2		0		BFC025-20							
1		1		BFC025-11							
0		2		BFC025-02							



BFC0-11



CWC Series Miniature Contactors Accessories

Auxiliary Contact Blocks Technical Specifications

Auxiliary Contacts BFC0/BFC4/BFC025 Technical Specifications			
Standards	IEC 60947-5-1, IEC 60947-4-1		
Rated insulation voltage U_i (pollution degree 3)	IEC, VDE 0660	(V)	1000
	UL, CSA	(V)	600
Rated operational voltage U_e	IEC, VDE 0660	(V)	690
	UL, CSA	(V)	600
Rated thermal current I_{th} ($\theta \leq 55^\circ\text{C}$)		(A)	10
Making capacity (rms)	U_e 400V 50/60 Hz - AC-15	(A)	30
Breaking capacity (rms)	U_e 400V 50/60 Hz - AC-15	(A)	3
Maximum IEC fuse class gL/gG without welding (short-circuit protection)		(A)	10
Minimum switching capacity		(V/mA)	17 / 5
Electrical endurance	(millions operations)		1
Mechanical endurance	(millions operations)		10

AC Auxiliary Contact Block Ratings UL/CSA											
Contact Rating Code Designation	Thermal Continuous Current (A)	Maximum Current (A)								Maximum Apparent Power (VA)	
		120V		240V		480V		600V		Make	Break
		Make	Break	Make	Break	Make	Break	Make	Break		
A600	10	60	6	30	3	15	1.5	12	1.2	7200	720
C600	2.5	15	1.5	7.5	0.75	3.75	0.375	3	0.3	1800	180

DC Auxiliary Contact Block Ratings UL/CSA				
Contact Rating Code Designation	Thermal Continuous Current (A)	Maximum Make or Break Current (A)		Maximum Make or Break Apparent Power (VA)
		125V	250V	
Q600	2.5	0.55	0.27	69
R300	1	0.22	0.11	28

Terminals Capacity and Tightening Torque – Power, Control Circuits, and Auxiliary Contact Blocks

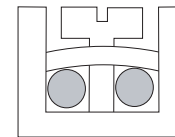

Terminals Capacity and Tightening Torque - Power, Control Circuits and Auxiliary Contact Blocks						
Terminal Type		CWC07...16		CWC025		BFC0/BFC4/BFC025
		Main Contacts	Auxiliary Contacts	Main Contacts	Auxiliary Contacts	Auxiliary Contacts
Solid cable	mm ²	1x 0.5–2.5	2x 0.5–2.5	1x 0.5–2.5	2x 0.5–2.5 1x 4	–
		2x 0.5–2.5		–		
Cable without ferrule	mm ²	1x 0.75–2.5	2x 0.5–2.6	2x 1–2.5	1x 0.75–2.5	1x 0.75–4
		2x 0.75–2.5		2x 2.5–6		2x 0.75–2.5
Cable with ferrule	mm ²	1x 2.5	–	2x 1–2.5	1x 0.5–2.5	1x 0.5–4
		2x 2.5		2x 2.5–6		2x 0.5–2.5
Wire gauge	AWG	1 or 2x 18–12	22–14	1 or 2x 18–10	22–14	22–14
Terminal screws		M3 flat/philips	M3.5 flat/philips	M3 flat/philips	M3.5 flat/philips	M3.5 flat/philips
Tightening torque	N·m [lb·in]	1–1.5 [8.85–13.28]	1–1.7 [8.85–15.05]	1.4–1.7 [12.39–15.05]	1–1.5 [8.85–13.28]	0.8–1.5 [7.08–13.28]



CWC Series Miniature Contactors Accessories

Surge Suppressors

Surge Suppressors						
Part Number	Price	Circuit Diagram	Voltage	Max. Clamping Voltage @ Current (Ip)	For Use With	
RCCO-1D49			12-24 VAC 50/60 Hz	N/A	RC Resistor/ Capacitor AC Loads (The capacitor is used to absorb the voltage spike)	CWC07 CWC09 CWC012 CWC016 CWC025
RCCO-2D53			24-48 VAC 50/60 Hz			
RCCO-3D55			50-127 VAC 50/60 Hz			
RCCO-4D63			130-250 VAC 50/60 Hz			
RCCO-5D84			275-380 VAC 50/60 Hz			
RCCO-6D73			400-510 VAC 50/60 Hz			
VRCO-1E49			12-48 VAC 50/60 Hz / 12-60 VDC	135V @ 10A	MOV Varistor AC or DC Loads The voltage surge is limited to 3 times the voltage rating of the suppressor (300% of the rated coil voltage). Clamps voltage	CWC07 CWC09 CWC012 CWC016 CWC025
VRCO-2E34			50-127 VAC 50/60 Hz / 60-180 VDC	395V @ 10A		
VRCO-3E50			130-250 VAC 50/60 Hz / 180-300 VDC	710V @ 10A		
VRCO-5D73			400-510 VAC 50/60 Hz	775V @ 10A		
DICO-1C33			12-600 VDC (1N4007)	N/A	Diode DC Loads The diode allows the remanent current to flow from a DC coil very smoothly and avoids an increase in voltage through the coil. Flyback suppression	CWC07 CWC09 CWC012 CWC016

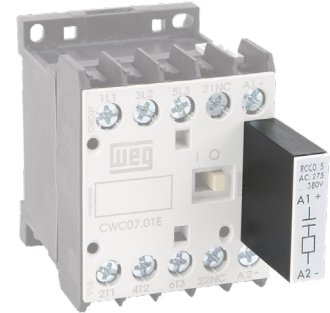

RCCO-5D84

Electronic Timing Relays

(CWC07...CWC025)

Star-Delta (TETCO) with LED Status Indication				
Part Number	Price	Voltage	Timing	Function
TETCO-U030S-D52		24-28 VDC 50/60 Hz	3 to 30 seconds	Star-Delta
TETCO-U030S-D61		110-130 VDC 50/60 Hz		
TETCO-U030S-D66		220-240 VDC 50/60 Hz		

Note: Right side mounting



TETCO-U030S-XXX

Timing Diagram

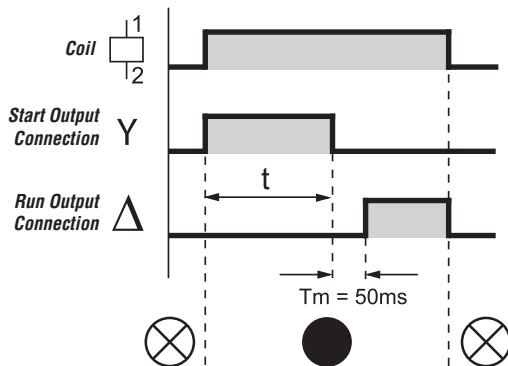

IEC Wiring Diagram

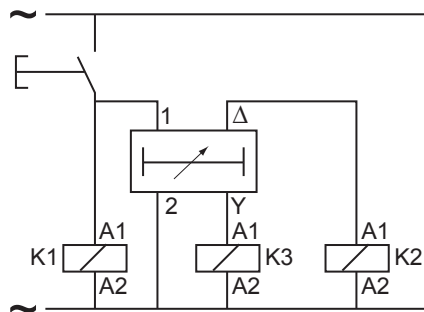

IEC Schematic Symbols

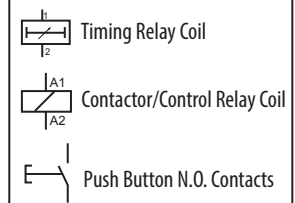

LED Off
 LED On
 Tm = Change over time



CWC Series Miniature Contactors Accessories

Wiring Kits (Jumper Assemblies)

- Quick and easy assembly for wye-delta and reversing starters
- Allows assembly of WEG overload relay RW17D

Reversing Wiring Kit for Mini Contactors CWC07 to CWC016										
Part Number	Price	Max Rated Operational Power of Three-Phase Motors 50/60 Hz kW [hp]					Rated Operational Current I _e AC-3 (U _e ≤ 440V)	Mini Contactors		
		220V 230V	380V	400V 415V	440V	500V		660V 690V	K1 = K2	
ECC0-R		1.5 [2]	3 [4]	3 [4]	3.7 [5]	3.7 [5]	3 [4]	7	CWC07	
		2.2 [3]	4 [5.4]	4 [5.4]	4.5 [6]	4.5 [6]	4 [5.4]	9	CWC09	
		3 [4]	5.5 [7.5]	5.5 [7.5]	5.5 [7.5]	5.5 [7.5]	5.5 [7.5]	12	CWC012	
		4 [5.4]	7.5 [10]	7.5 [10]	7.5 [10]	7.5 [10]	7.5 [10]	16	CWC016	
Star-Delta Wiring Kit for Mini Contactors CWC07 to CWC016										
Part Number	Price	Max Rated Operational Power of Three-Phase Motors 50/60 Hz kW [hp]			Rated Operational Current I _e AC-3 (U _e ≤ 440V)	Mini Contactors				
		220–230 V	400–415 V	660–690 V		K1 = K2	K3			
ECC0-SD		3.7 [5]	5.5 [7.5]	5.5 [7.5]	12	CWC07	CWC07			
		3.7 [5]	7.5 [10]	9.2 [12.5]	18	CWC012				
		5.5 [7.5]	11 [15]	15 [20]	25	CWC016	CWC09			

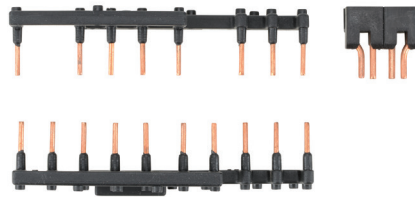
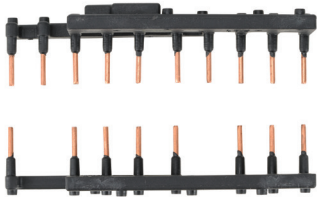

ECC0-R Wiring Diagram

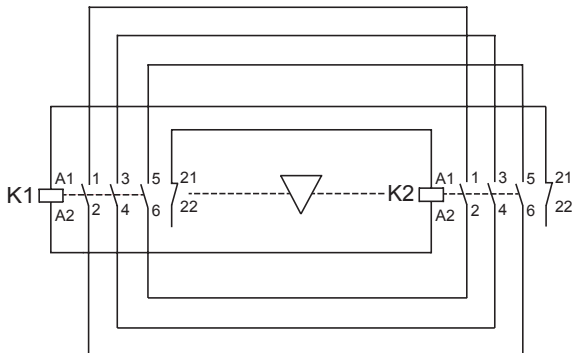

ECC0-SD Wiring Diagram

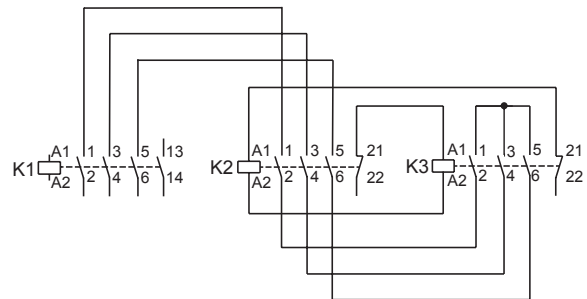



CWC Series Miniature Contactors Accessories

Mechanical Interlock Block and Latch Block

Mechanical Interlock Block and Latch Block			
Part Number	Price	Description	For Use With
BICO		Mechanical interlock, front mounted, use with any CWC07 through CWC016 series miniature contactor. Mechanically connects two CWC series mini contactors and prevents both contactors from being pulled in at the same time. For reversing contactors.	CWC07 CWC09 CWC012 CWC016
RMCO		Latch block, front mounted, use with any CWC07 through CWC016 series miniature contactor. Mechanically connects two CWC series mini contactors and enables one contactor to operate with a pulse input signal. Retention block for contactor.	



Note: Do not use BICO or RMCO accessory with mini contactors with low consumption DC coils.

Operation Description of Latched Block RMCO

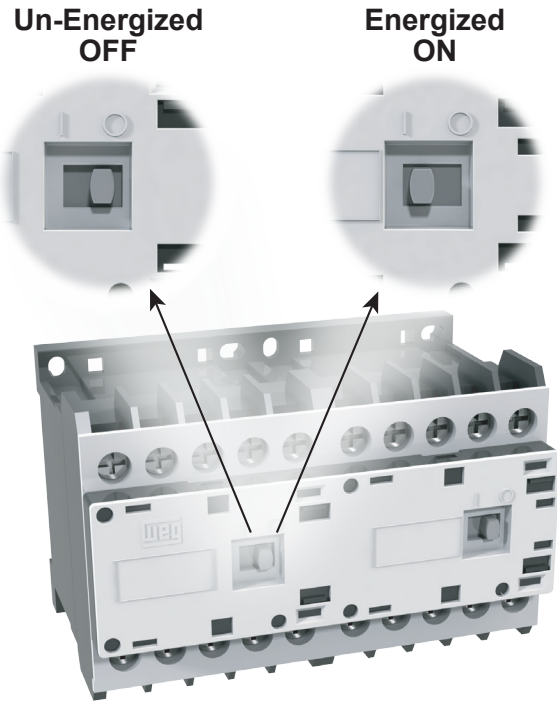
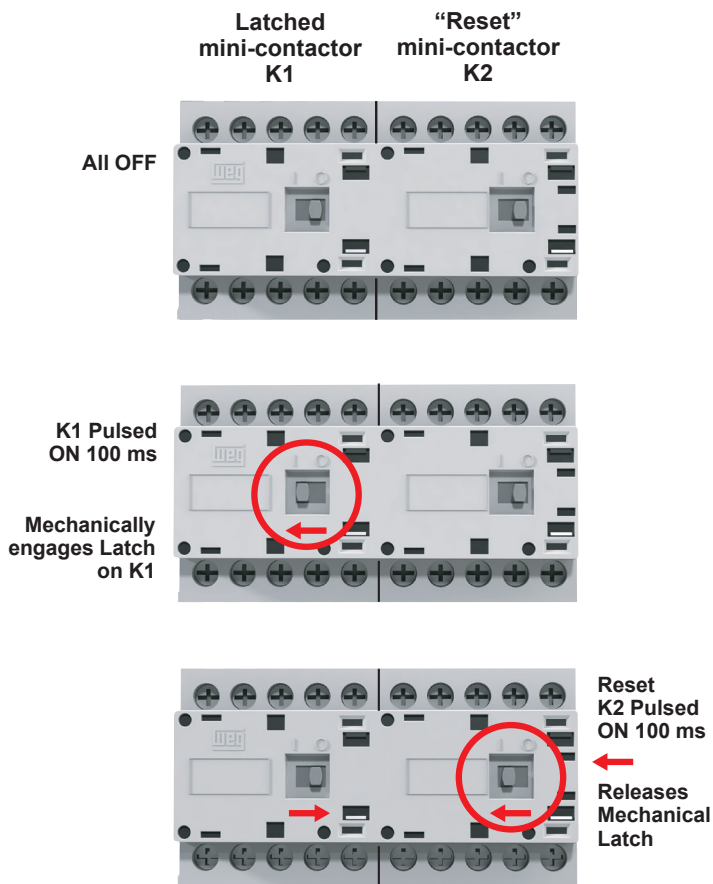

- After a minimum pulse of 100ms on mini contactor's coil (K1), the RMCO will keep K1 contactor switched on;
- The mini contactor K1 will only return to rest position after miniature contactor's coil (K2) has been energized by a releasing pulse of 100ms;
- The mechanical latch only occurs when mini contactor (K1) is energized (ON).

Note: If RESET miniature contactor's coil (K2) remains energized, the latching of mini contactor (K1) is not enabled.

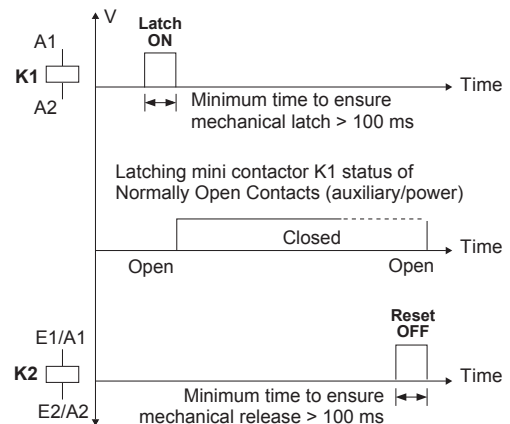



CWC Series Miniature Contactors Accessories - Dimensions

Dimensions mm [in]

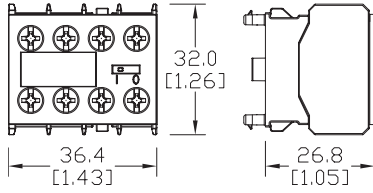

BFCO-xx, BFC4-xx, BFC025-xx

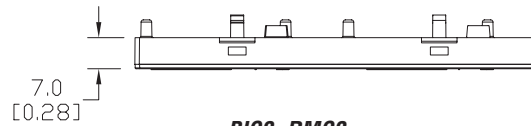
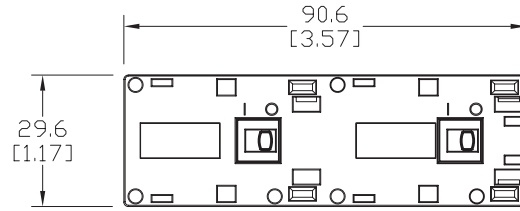

BICO, RMC0

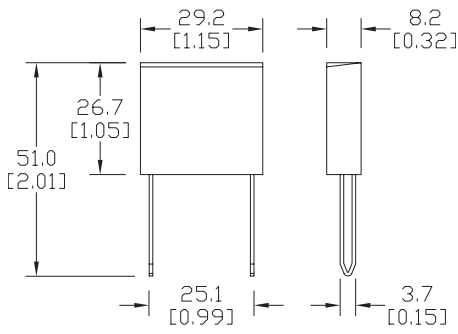

RCCO-xxxx, VRCO-xxxx, DICO-xxxx

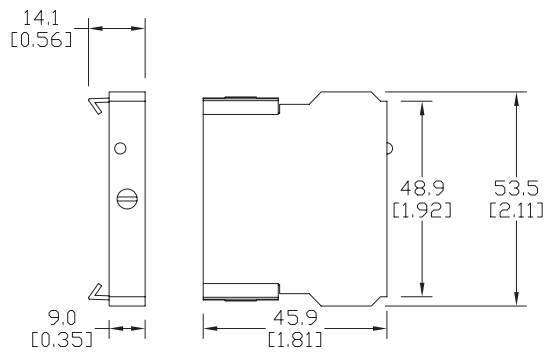

TETCO-U030S-Dxx



RW Series Overload Relays For CWC Miniature Contactors

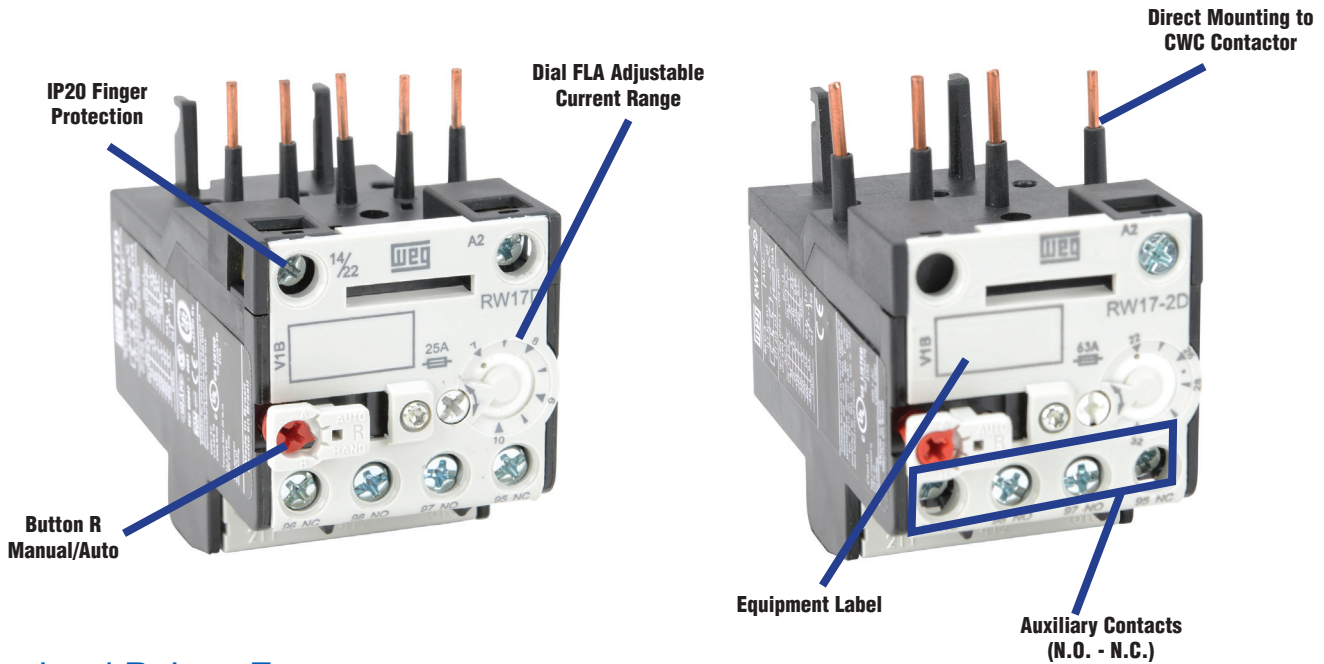

Overload Relays Features

RW overload relays are an important part of WEG controls' range of products. As usual in WEG products, an extended operational service life is one of the main features you can find in RW overload relays.

WEG's RW class 10 thermal overload relays are designed for use with, and as perfect complement to, the CWC miniature contactors.

RW relays are available in compact frame sizes from 0.28 A to 32A. Mounting an RW series overload relay directly to a WEG CWC miniature contactor creates an across-the-line starter capable of controlling motors from fractional to 15hp @ 460V.

Standards and Approvals

- IEC 60947 and VDE 0660.
- cULus listed file no. E189202
- CE marked low voltage directive 2006/95/EC
- Marine



Modern Architecture

Previous models of open overloads with "heaters" encounter problems in the field, including:

- Inaccurate trip point, because of uneven screw tightness when installed on individual phases
- Ambient problems, such as dust and other contaminants, because of their open design
- Inability to protect in case of single phase failure
- Nuisance tripping, because no temperature compensation is possible.

The modern design of WEG overload relays solves all of these problems. RW overload relays are fitted with fixed bimetallic elements, which eliminate any need for heater elements for field installation or future upgrading to a more efficient motor. All sizes provide complete motor protection by offering:

- Ambient temperature compensation (-4°F to +140°F)
- Phase loss sensitivity protection
- Current unbalance sensitivity

Dial FLA Setting

The trip-current is set via an adjustable dial designed with the motor's full load current (FLA) in mind.

Temperature Compensation

Because RW overload relays include a fourth bimetallic strip in addition to the three that are directly heated by the motor current, ambient temperature variations in the range of -4°F to +140°F are no obstacle for accurate protection of your motors even in the toughest conditions.

Phase Loss Sensitivity

WEG overload relays include standard phase failure sensitivity protection. This feature ensures fast tripping in case of phase loss, protecting your motor and avoiding expensive repairs.

Multi Function Button "R"

The programmable RESET button can be selected to operate in a Manual or Automatic mode, with or without TEST capabilities of the isolated "trip" N.C. and "alarm" N.O. auxiliary contacts. The "R" multifunction RESET / TEST button can be set in four different positions:

- H (manual RESET only)
- HAND (manual RESET/TEST)
- AUTO (automatic RESET/TEST)
- A (automatic RESET only)

In HAND and AUTO positions, when gray R button is pushed, both N.O. 97-98 and N.C. 95-96 contacts change state.



RW Series Thermal Overload Relays For CWC Miniature Contactors

Thermal Overload Relays Features

- Adjustable tripping current
- Phase-loss sensitivity (All phases must be connected. See motor wiring diagrams.)
- Tripping class 10
- Auxiliary contacts 1 N.O. + 1 N.C.
- Temperature compensation from -20° to +60°C [-4°F to +140°F]
- Hand/Auto/Reset button
- Equipment Label

Thermal Overload Relay Selection Guide						
Part Number	Price	For use with	Setting range of overload release (A)	*Short-Circuit Protective Device		
				IEC Max Fuse	UL Max Fuse	UL Max Breaker
RW17-1D3-D004		CWC07 CWC09 CWC012 CWC016	0.28-0.4	2	15	15
RW17-1D3-C063			0.4-0.63	2	15	15
RW17-1D3-D008			0.56-0.8	2	15	15
RW17-1D3-D012			0.8-1.2	4	15	15
RW17-1D3-D018			1.2-1.8	6	15	15
RW17-1D3-D028			1.8-2.8	6	15	15
RW17-1D3-U004			2.8-4.0	10	15	15
RW17-1D3-D063			4.0-6.3	16	25	25
RW17-1D3-U008			5.6-8.0	20	30	30
RW17-1D3-U010			7.0-10	25	40	40
RW17-1D3-D125			8.0-12.5	25	50	50
RW17-1D3-U015			10.0-15.0	35	60	60
RW17-1D3-U017			11.0-17.0	35	60	60
RW17-2D3-U010			CWC025	7-10	25	40
RW17-2D3-D125		8-12.5		25	50	50
RW17-2D3-U015		10-15		35	60	60
RW17-2D3-U017		11-17		35	60	60
RW17-2D3-U023		15-23		50	90	90
RW17-2D3-U032		22-32		63	90	125

* Note: Type 2 short-circuit coordination per IEC 60947-4-1. UL fuse type class CC.

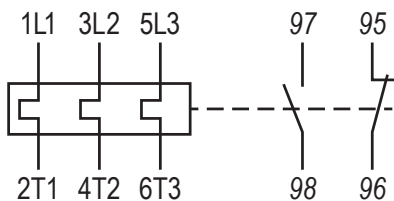

Circuit Diagram

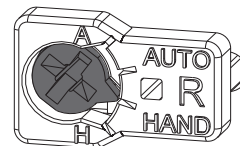

Hand/Auto/Reset Button



RW Series Thermal Overload Relays For CWC Miniature Contactors

Thermal Overload Relays Technical Characteristics

RW Series Thermal Overload Relays General Ratings		
Standards		IEC 60947-1 / 60947-4-1, EN 60947-1 / 60947-4-1, UL 508; CSA C.22.2/14; VDE 0660/102
Number of poles		3
Tripping class		10
Phase loss sensitive		Yes
Temperature compensation		Yes
Rated insulation voltage IEC 60947-4-1		690V
Rated insulation voltage UL/CSA		600V
Rated operation voltage U_e IEC 60947-4-1		690V
Rated operation voltage U_e UL/CSA		600V
Rated impulse voltage U_{imp}		6kV
Current	Direct	Yes
	Alternating	up to 400Hz
Degree of protection - protection against contact acc. VDE 0160 - Part 100		IP20
Ambient Temperature	Storage	-50 to +80°C [-58 to 176°F]
	Operating	-20 to +70°C [-4 to 158°F]
	Ambient temperature compensation	-20 to +60°C [-4 to 140°F]
Pollution degree per IEC 60947-4-1		3
Mounting		Direct on contactor
Current heat loss	Lower value of setting range	0.9 W
	Higher value of setting range	1.4 W
Weight		0.15kg [0.33lb]
Shock resistance IEC 60068-2-27		8g [10ms]
Main terminals capacity <small>(Cross / Slotted Combination)</small>	Fine - stranded with sleeve (ferrule)	1.5–10 mm ²
	Coarse - stranded / solid	1.5–6.0 mm ²
	Stranded / solid (UL / CSA)	14–6 AWG
Tightening torque		1.4–2.3 N·m [12.4–20.4 lb·in]
Short circuit rating 600V		5kA



RW Series Thermal Overload Relays For CWC Miniature Contactors

Thermal Overload Relays Technical Characteristics

Auxiliary Contacts General Ratings RW17D			
Front auxiliary contact	1 NO + 1 NC		
Rated auxiliary contacts IEC/EN 60947			
AC-14/15	24V	(A)	4.0
	60V	(A)	3.5
	125V	(A)	3.0
	230V	(A)	2.0
	400V	(A)	1.5
	500V	(A)	0.5
	690V	(A)	0.3
DC-13/14	24V	(A)	1.0
	60V	(A)	0.5
	110V	(A)	0.25
	220V	(A)	0.1
Rated thermal current	(A)	6	
Short circuit protection			
Fuses type gL/gG	(A)	6	
Auxiliary terminals capacity			
Fine - stranded with ferrule	(mm ²)	1.0 – 2.5	
Coarse - stranded/solid	(mm ²)	1.0 – 2.5	
Stranded/solid (UL/CSA)	(AWG)	16 – 12	
Tightening torque	(N·m)	1.0 – 1.5	
	(lb·in)	8.9 – 13.3	



RW Overload Relays Tripping Characteristics

These tripping characteristics show the tripping of RW overload relays in relation to the current. They show the mean values of the tolerance ranges at an ambient temperature of 20°C (68°F), starting from cold state. The tripping time of the overload releases at operational temperature is reduced to approximately 25% of the values shown. Under normal operational conditions, all three phases of the RW relays should be loaded.

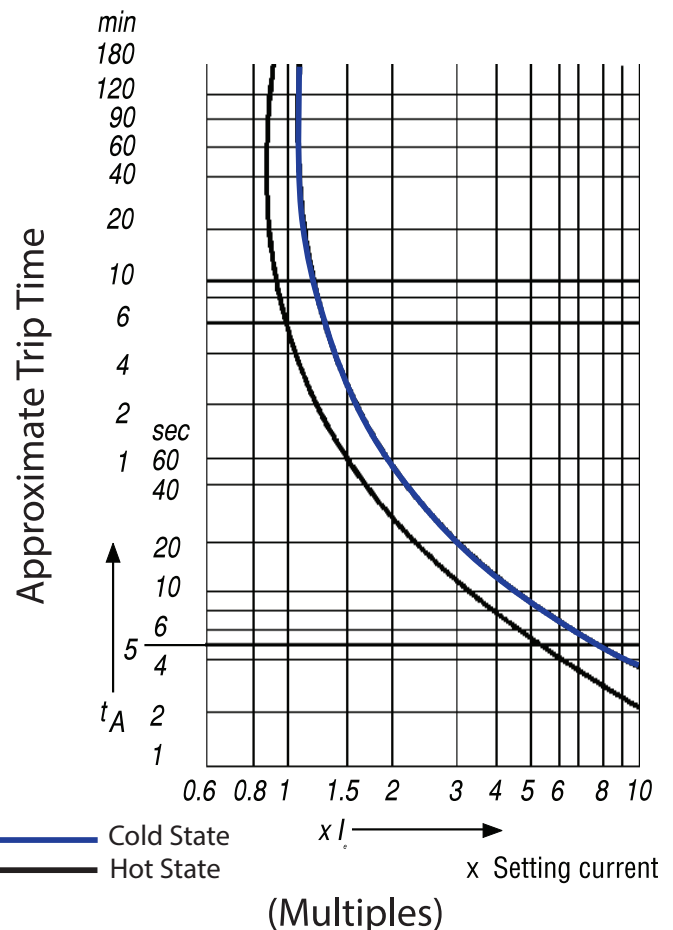



RW Series Overload Relays For CWC Miniature Contactors

Overload Relays Dimensions

Dimensions mm [inches]

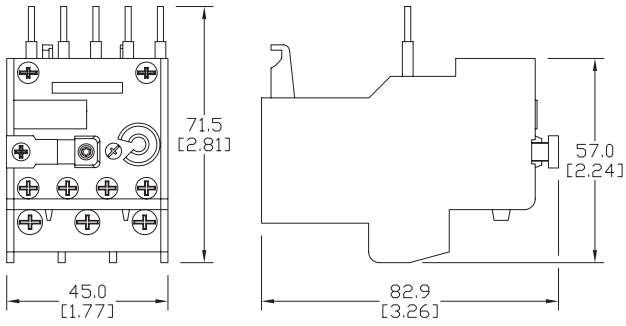

RW17-1D

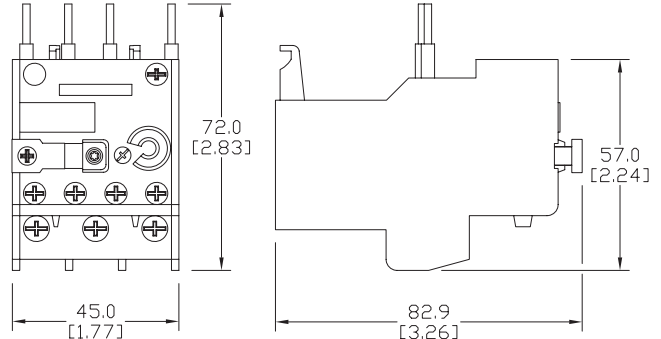

RW17-2D

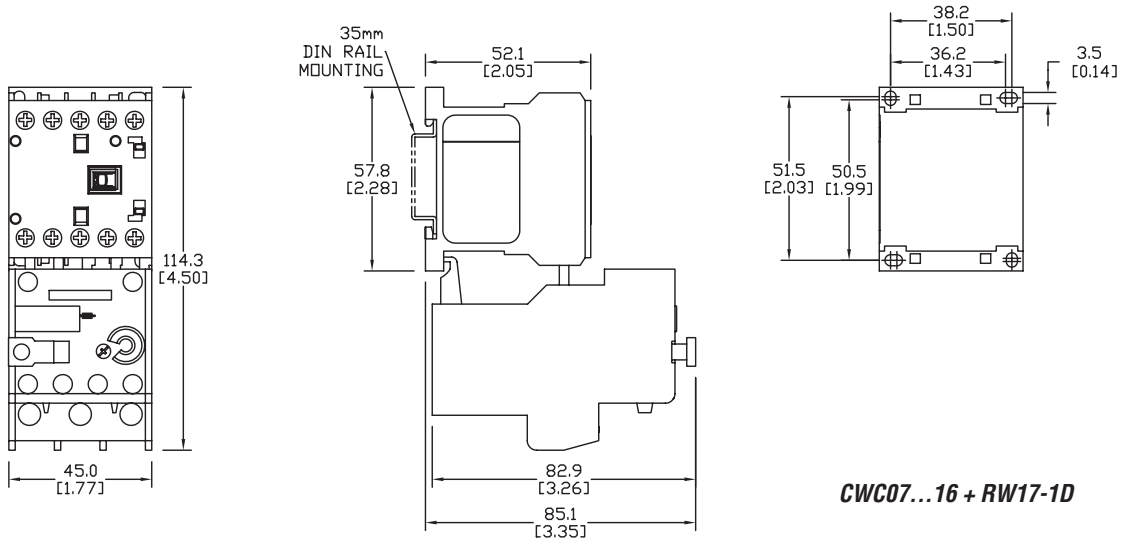

CWC07...16 + RW17-1D

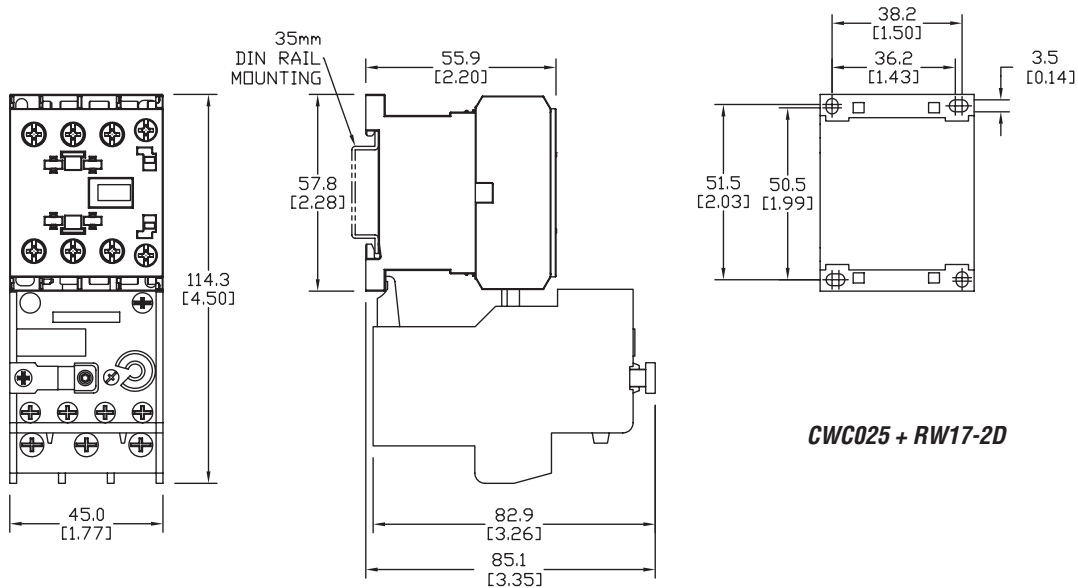

CWC025 + RW17-2D

Reduced Voltage Starters – Wye Delta

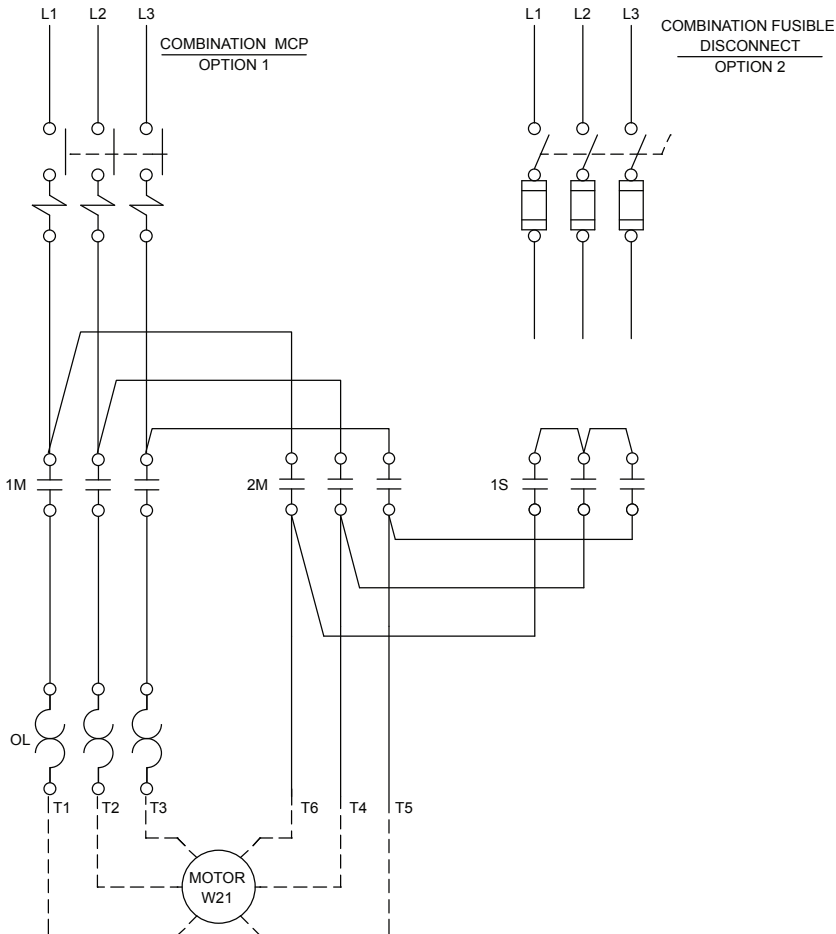
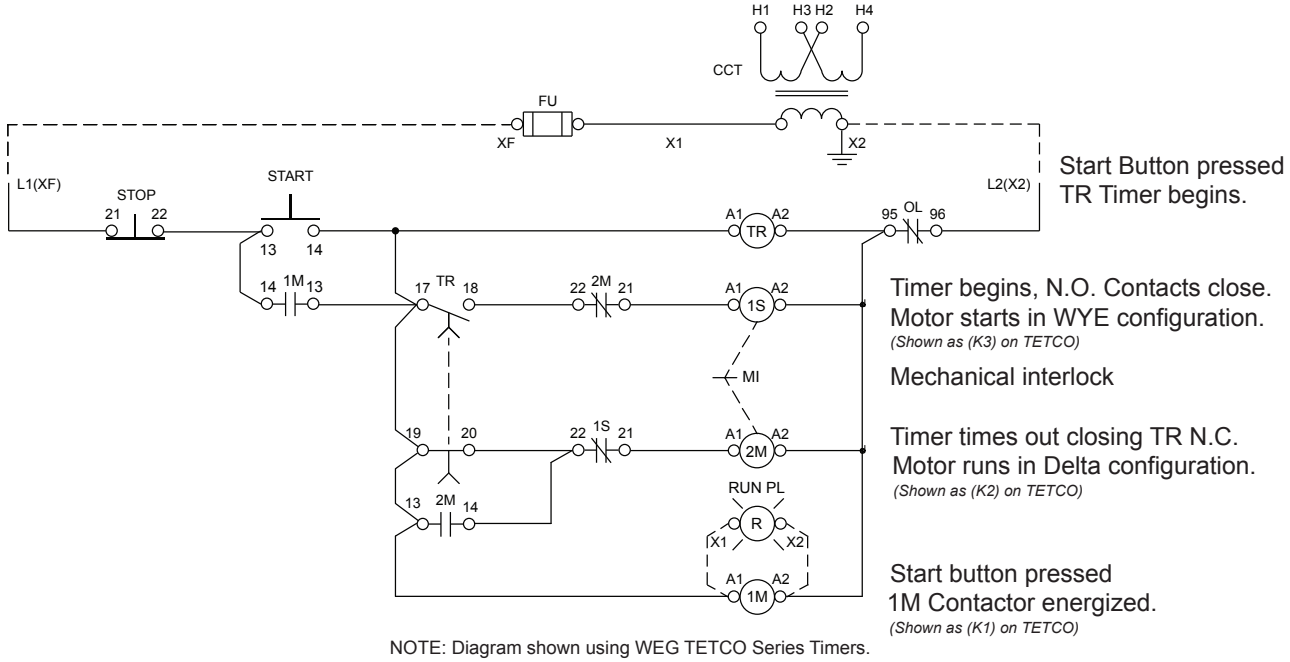



Wiring Diagrams

Motor Starters Non-Reversing

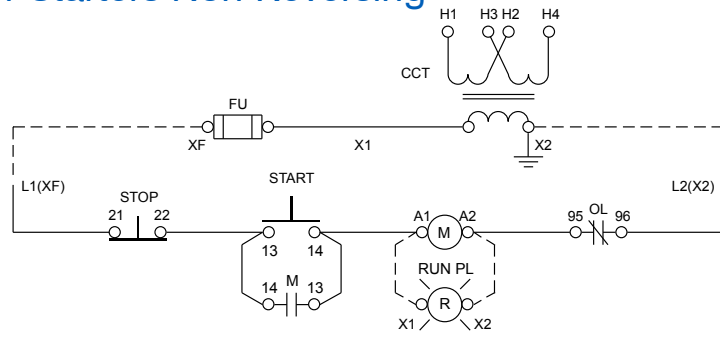

START - STOP - PUSHBUTTONS

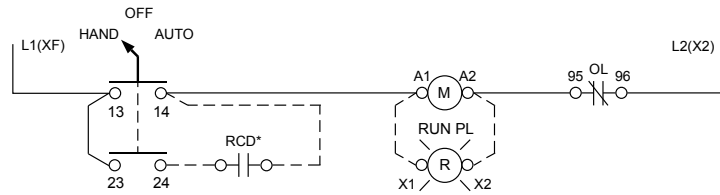

* REMOTE CONTROL DEVICE BY CUSTOMER

HAND - OFF - AUTO SELECTOR SWITCH

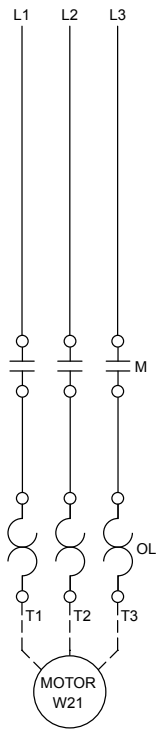
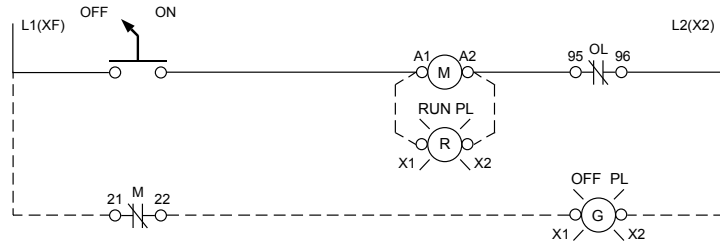

NON COMBINATION 3-PHASE

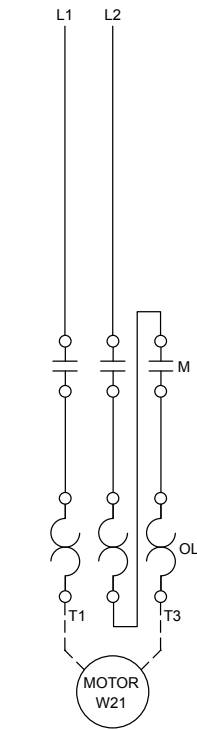

NON COMBINATION 1-PHASE

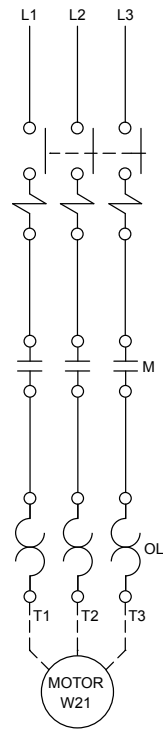

COMBINATION MCP

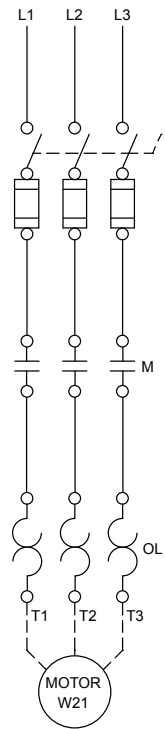

COMBINATION FUS / NON FUS. DISC.