

# Dold UF6925 Series 2-Channel Emergency Stop and Safety Gates



Designed to protect people and machines in applications with E-stop buttons and safety gates.

- 17.5 mm (0.69 in) slim housing
- Supply voltage 8-36 VDC
- Outputs: N.O. contacts (all models) plus 1 N.C. contact on [UF6925-22-DC8-36](#)
- Overvoltage and short-circuit protection
- Monitored restart
- LED indicators for power and state of operation

Safety Data – Values per EN ISO 13849-1	
<b>Category</b>	4
<b>Performance level</b>	e
<b>MTTF<sub>d</sub></b>	284.6 years
<b>DC<sub>avg</sub></b>	99%
Safety Data – Values per IEC/EN 62061 /IEC/EN 61508	
<b>SIL CL</b>	3
<b>SIL</b>	3
<b>HFT (Hardware Failure Tolerance)</b>	1
<b>DC<sub>avg</sub></b>	99%
<b>PFH<sub>D</sub></b>	8.30e-11

Safety Relays Selection Chart				
Part Number	Price	Marking Type	Voltage	Outputs
<a href="#">UF6925-03-DC8-36</a>		2-channel E-STOP / GATE	8-36 VDC	3 N.O.
<a href="#">UF6925-22-DC8-36</a>				2 N.O. and 1 N.C.
<a href="#">UF6925-02-DC8-36</a>				2 N.O.

UF6925 Controllers Safety Relay Specification Table	
<b>General Specifications</b>	
<b>Temperature</b>	Storage: -25°C to 85°C (-13°F to 185°F)
<b>Altitude</b>	< 2,000m (6562ft)
<b>Vibration Resistance</b>	IEC/EN 60-068-2-6
<b>Degree of Protection</b>	Housing: IP40; Terminals IP20
<b>Housing</b>	UL 94V-0 Thermoplastic; DIN mount 35mm (1.38 in) x 7.5 mm (0.30 in)
<b>Weight</b>	140g (4.94 oz)
<b>Agency Approvals and Standards</b>	CSA, cULus file E107778, CE, RoHS, TUV
<b>Terminal Designation per EN 50 005 Wire Connections</b>	Min. 60°C copper conductors 28-14 AWG
<b>Wire Fixing</b>	Fixed spring clamp terminals
<b>Input Specifications</b>	
<b>Nominal Voltage</b>	8-36 VDC
<b>Voltage Range</b>	0.8-1.1 VDC
<b>Maximum Consumption</b>	< 1.6 W at 24VDC; < 2.2 W at 8-36 VDC
<b>Nominal Frequency</b>	-
<b>Minimum Off-time</b>	150ms
<b>Control Voltage on S11 At UN</b>	23VDC
<b>Control Current Typ. Over S12, S22</b>	30mA at UN
<b>Min. Voltage on S12, S22 (relay activated)</b>	19VDC
<b>Short Circuit Protection</b>	Internal with PTC (Positive Temperature Coefficient resistor)
<b>Overvoltage Protection</b>	Internal VDR (Voltage Dependent Resistor)
<b>Output Specifications</b>	
<b>Electrical Contact Life</b>	AC 15 at 8A, 230VAC; > 1.0x10 <sup>5</sup> switching cycles
<b>Mechanical Life</b>	> 40x10 <sup>6</sup> switching cycles
<b>Contact Type</b>	UF6925.02: 2 N.O. contacts – UF6925.03: 3 N.O. contacts UF6925.22: 2 N.O. contacts, 1 N.C. contact positively driven, N.O. contacts are safety contacts
<b>Operating time at UN</b>	< 350ms
<b>Release Delay</b>	< 90ms at 8-36 VDC – Disconnecting S12, S22: DC units: < 25ms
<b>Nominal Output Voltage</b>	AC: 230V; DC: See continuous current limit curve in installation manual.
<b>Thermal Current (I<sub>th</sub>)</b>	Max. 8A. See continuous current limit curve in installation manual.
<b>Short Circuit Strength</b>	Max. fuse rating: 8A gL (IEC/EN 60 947-5-1); Line circuit breaker: B 6A
<b>Switching Capacity (IEC/EN 60 947-5-1)</b>	AC15 N.O. contact: 3A / 230VAC; N.C. contact 1A / 230VAC DC13 N.O. contact: 2A / 24VDC; N.C. contact: 2A / 24VDC DC13 N.O. contact: 4A / 24VDC at 0.1 Hz; N.C. contact: 4A / 24VDC at 0.1 Hz
<b>Switching Frequency</b>	Max. 1200 switching cycles/hr

# Dold UF6925 Series 2-Channel Emergency Stop and Safety Gates

## Block Diagrams

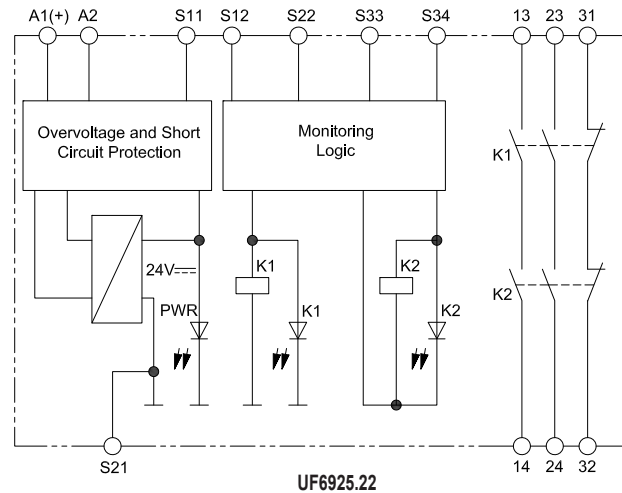
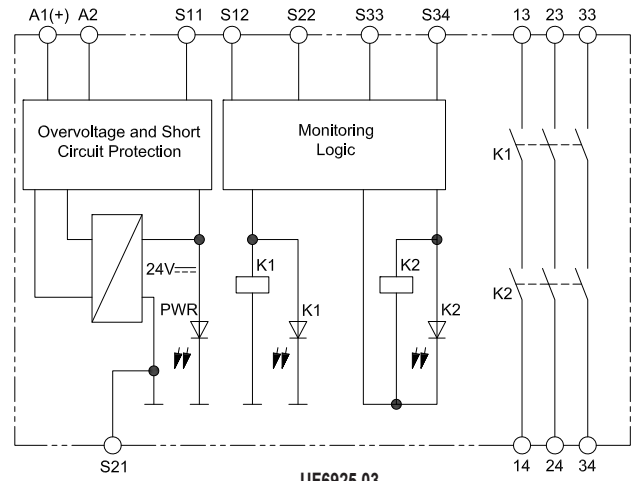
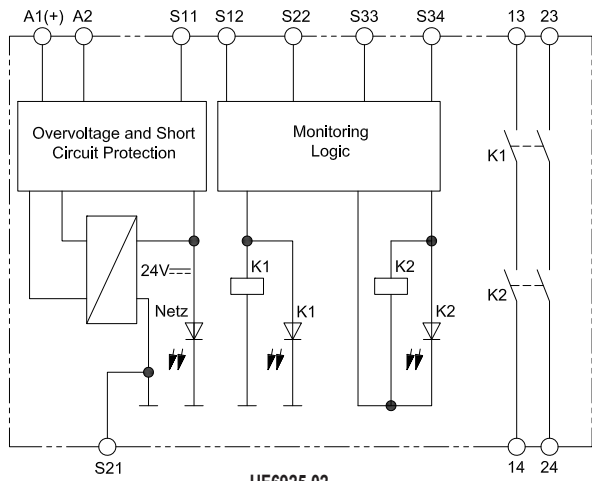

## Dimensions

mm [in]

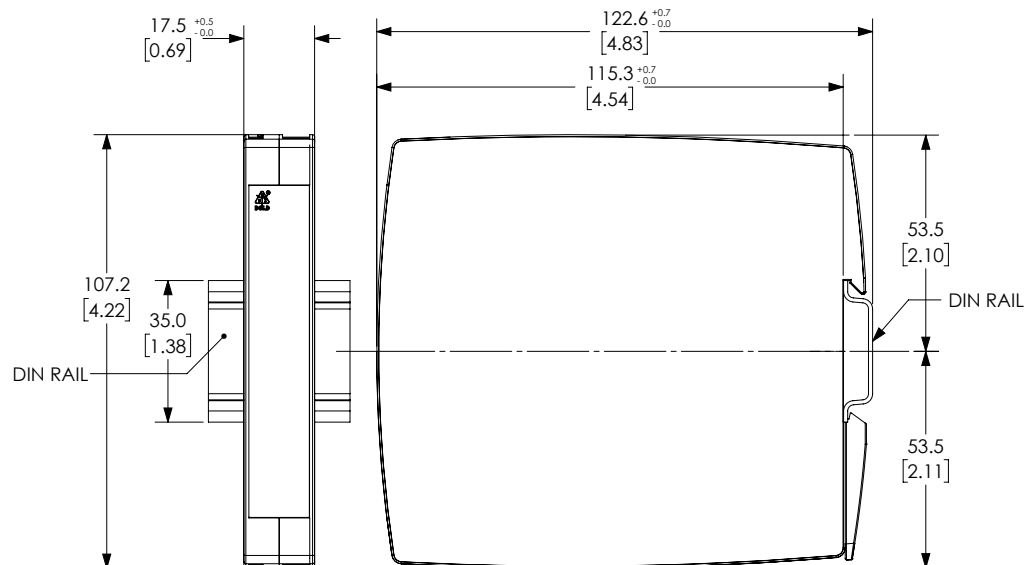

# Dold UF6925 Series 2-Channel Emergency Stop and Safety Gates

## Application Examples

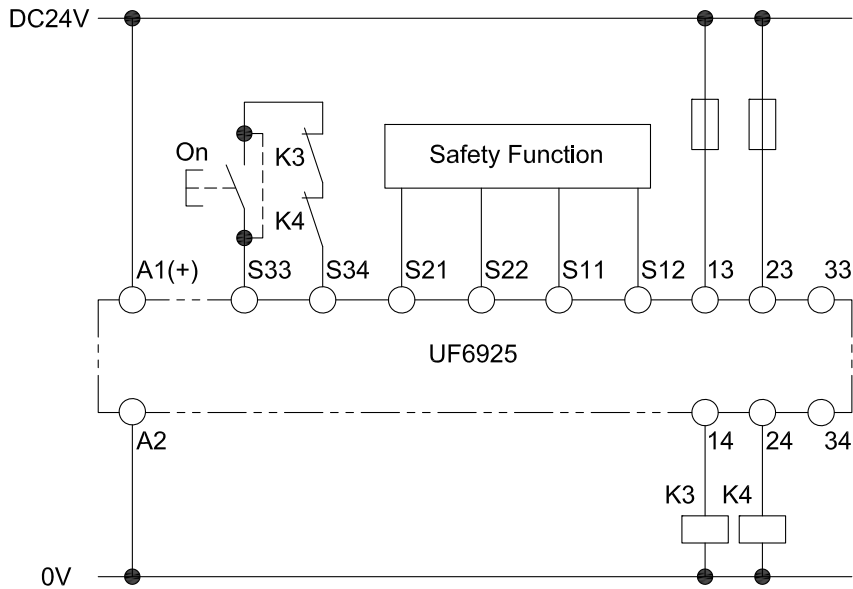

A jumper must be fitted at S33-S34 for the automatic ON function. The ON pushbutton is not required. The required start function has to be selected on switch S1 before starting the device. See “Unit Programming.”

### Safety function for units with cross fault detection (pay attention to “Unit Programming”!)



### Safety function for units without cross fault detection (pay attention to “Unit Programming”!)

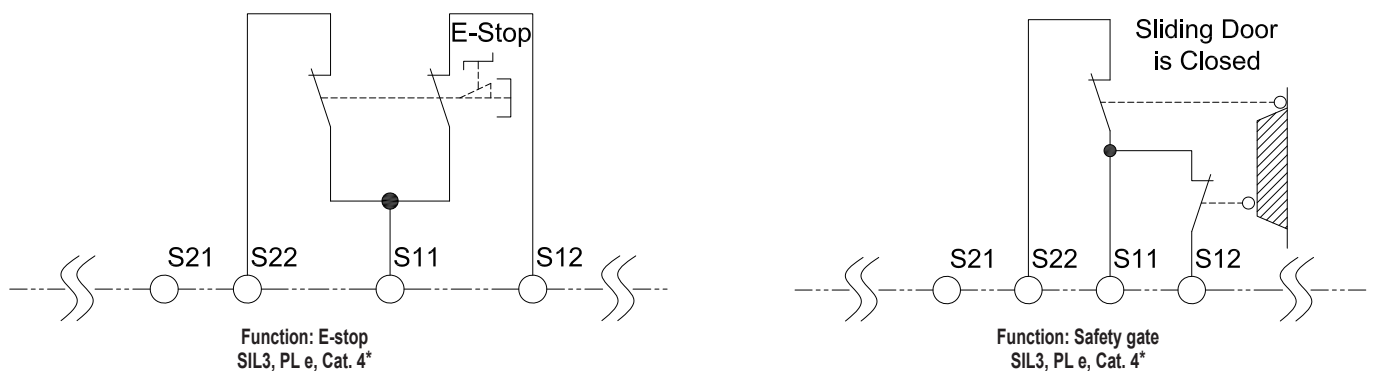

\* To achieve the safety classification, cross fault wiring must be installed.

# Safety Products



*Warning: Safety products sold by AutomationDirect are Safety components only. The purchaser/installer is solely responsible for the application of these components and ensuring all necessary steps have been taken to assure each application and use meets all performance and applicable safety requirements and/or local, national and/or international safety codes as required by the application. AutomationDirect cannot certify that our products, used solely or in conjunction with other AutomationDirect or other vendors' products, will assure safety for any application. Any person using or applying any products sold by AutomationDirect is responsible for learning the safety requirements for their individual application and applying them, and therefore assumes all risks, and accepts full and complete responsibility, for the selection and suitability of the product for their respective application.*

*AutomationDirect does not provide design or consulting services, and cannot advise whether any specific application or use of our products would ensure compliance with the safety requirements for any application.*