

C-more Micro 3-inch EA1 Panel Accessories

DC Power Adapter

The **C-more** Micro 3-inch EA1 series panel is designed to use the 5 VDC power that is available from an RJ12 serial communications port found on some AutomationDirect PLC's. The EA-MG-P1 DC Power Adapter requires power from a Class 2, 12-24 VDC source. This adapter is designed to easily snap on to the rear of a **C-more** Micro 3-inch EA1 series panel or the rear of an optional Keypad Bezel being used with a **C-more** Micro 3-inch EA1 series panel.

Part No. **EA-MG-P1**



Dimensions

Units: inches [mm]

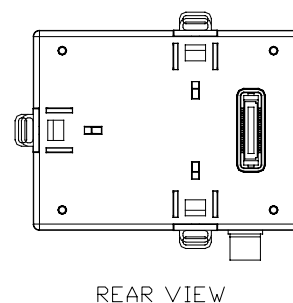
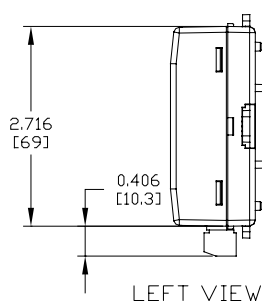
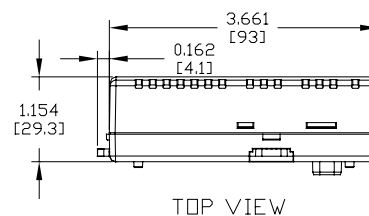

Panel overall depth with adapter installed

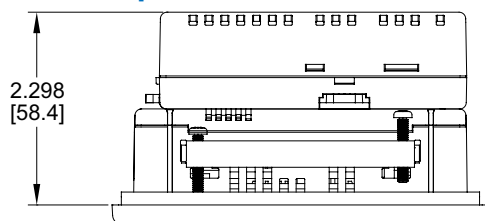

Units: inches [mm]

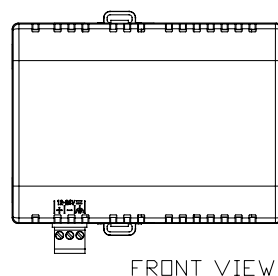

DC Power Adapter Specifications	
Part Number	EA-MG-P1
Electrical	
• Input Voltage	12-24 VDC
• Input Voltage Range	10.8-26.4 VDC
• Power Consumption	100 mA @ 24 VDC
• Maximum Power	2.90 Watts
• Maximum Inrush Current	5 A @ 500 μ s with 12 VDC applied, 10 A @ 500 μ s with 24 VDC applied
• Recommended Fuse	Type AGC fast acting glass fuse, 750 mA, 250 VAC, ADC #AGC-75
• Connector Type	3-pin screw type terminal block
Physical	
• Weight	2.8 oz. [80 g]
Environmental	See environmental specifications at the beginning of this catalog section.



NOTE: Recommended DC power supply to power either DC Power Adapter, AutomationDirect Part No. PSC-24-015 or PSC-24-030.

C-more Micro 3-inch EA1 Power Connection Wiring

Providing power to the touch panel

- The **C-more** 3-inch Micro panel is powered during programming from the PC through the USB to RS-232 Programming Cable Assembly, EA-MG-PGM-CBL.
- During operation, the **C-more** Micro panel can be powered from most AutomationDirect PLC's RJ12 serial communications port by using the DV-1000CBL communications cable.
- Or install either the DC Power Adapter, EA-MG-P1, or the Serial Port with DC Power Adapter, EA-MG SP1, to the rear of the panel and supply the adapter from a Class 2, 12-24 VDC power source.

3-inch Panel powered from AutomationDirect PLC via communications cable

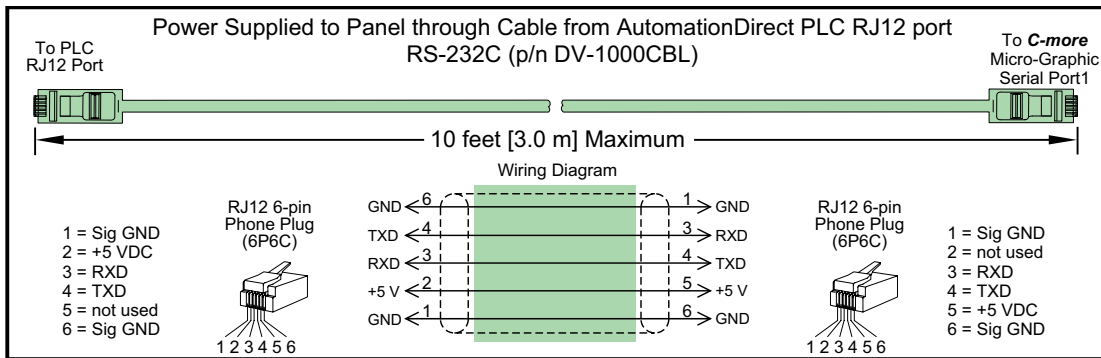

3-inch panel powered from a DC power adapter – wiring diagram

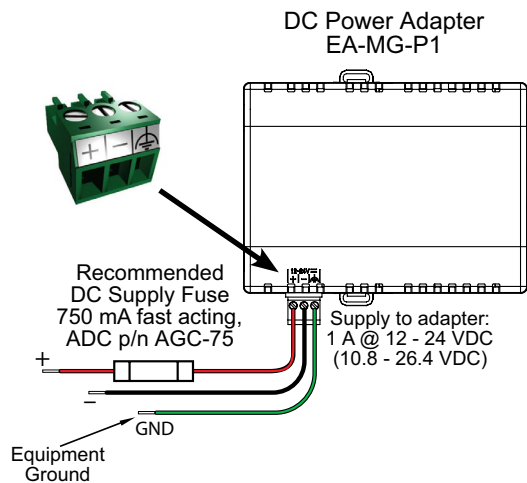

NOTE: Recommended DC power supply to power either DC Power Adapter, AutomationDirect Part No. PSC-24-015 or PSC-24-030.



NOTE: The maximum communication cable length when a 3-inch panel is powered from an optional DC power adapter is 50 feet.