

Fuji Molded Case Circuit Breakers Overview

Overview

Fuji Molded Case Circuit Breakers are more compact (especially 100A, 125A, 250A frames) than any breakers on the market, so they take up less space in control panels.

This product group maintains conformity to all Worldwide standards.

Agency Approvals

- UL listed, MCCB, File: E90584
- UL listed, Accessories, File E93289
- CE marked
- CCC marked
- TUV certified

Standards

- UL 489
- CSA C22.2 No.5
- IEC 60947-2
- EN 60947-2
- GB 14048.2
- JIS C8201-2-1, 2 (ANN.1, 2)



Fuji Electric Molded Case Circuit Breakers Technical Specifications

Circuit Breaker Type	Ampere Rating at 40°C	No. Poles	Volts		Type of Trip*	UL 489 Interrupting Ratings (rms Symmetrical Amperes) (kA)			
			AC	DC		Volts AC (50/60 Hz)			Volts DC
						240	480	600	
BW125JAGU	15-125	3	600	250	N.I.T.U	50	30	10	10
BW250JAGU	125-250	3	600	250	N.I.T.U	50	30	10	10
BW400SAGU	250-400	3	480	250	N.I.T.U	50	35	–	10
BW630RAGU	500-600	3	480	250	N.I.T.U	100	50	–	10
BW800RAGU	700-800	3	480	250	N.I.T.U	100	50	–	10

Operating Range: -10 to 50°C [14 to 122°F]

*Note: N.I.T.U denotes non-interchangeable trip unit.

**Note: For DC or 1-phase AC applications, use the two outside poles of the 3-pole circuit breaker

Fuji Molded Case Circuit Breakers 800A Frame



BW800RAGU-3P700SB

Fuji BW800A series MCCBs are 800 amp frame, 3-pole, non-adjustable magnetic trip, molded case circuit breakers (MCCB). The BW800 series is suitable for reverse feed applications.

Included with each MCCB are Line and Load-side lug terminals and mounting hardware. Accessories are not pre-installed and are sold separately.

BW800-Frame Series Three-Pole Molded Case Circuit Breakers									
Part Number	Price	Frequency	Rated Interrupting Capacity (kA)						
			Rated Current	UL489 CAN/CSA C22.2 No. 5		IEC60947-2, JIS C 8201-2-1 Icu/Ics		GB14048.2 Icu/Ics	
			Ampere Rating	Voltage	Interrupt Capacity	Voltage	Interrupt Capacity	Voltage	Interrupt Capacity
BW800RAGU-3P700SB	5.00	50/60 Hz	700	480V/Δ AC 480V/Y AC 240V AC 250V DC	50 kA 50 kA 100 kA 10 kA	690V AC 500V AC 440V AC 400V AC 380V AC 240V AC 250V DC	15/8 kA 36/18 kA 50/25 kA 50/25 kA 50/25 kA 100/50 kA 40/20 kA	400V AC 230V AC	50/25 kA 100/50 kA
BW800RAGU-3P800SB	5.00		800						

Note: SCCR = UL489 interrupting capacity

BW800-Frame Accessory Selection Guide		
Part Number	Price	Description
BW9W1SHA		Field installable auxiliary contact switch, use with BW400, BW630 and BW800 series MCCBs. SPDT. 20AWG lead wires, 19.69" long, left side mount only
BW9FHA-R		Field installable DC shunt trip, use with BW400, BW630 and BW800 series MCCBs; 24 VDC/AC, 20 AWG lead wires 19.69" long, left and right side mount
BW9FHA-A		Field installable AC shunt trip, use with BW400, BW630 and BW800 series MCCBs; 100-120 VAC, 20 AWG lead wires 19.69" long, left and right side mount
BW9RHA-R		Field installable DC undervoltage release, for BW400, BW630 and BW800 series MCCBs; 24-48 VDC, 20AWG lead wires, 19.69" long, left side mount only
BW9RHA-1		Field installable AC undervoltage release, for BW400, BW630 and BW800 series MCCBs; 120-130 VAC, 20AWG lead wires, 19.69" long, left side mount only
BW9BTJA-L3W*		Terminal cover for BW400-frame MCCBs, line and load side, package of 2
BW9V0JA		NEMA 12 rotary handle for BW800-Frame. Position indicating; lock-off feature. Shaft length: 0.39"
BZ-VS2		NEMA 12 rotary handle shaft for BW9V0HA and BW9V0JA, BW400, BW630 and BW800 Frames. Steel shaft length: 3.48" (88 mm)
BZ-VS2-24		NEMA 12 rotary handle shaft for BW9V0HA and BW9V0JA, BW400, BW630 and BW800 Frames. Steel shaft length: 24" (610 mm)
BW9F0JA-15A**		NEMA 12 flexible shaft handle for BW630 and BW800 frames. Flange mounted. Lockable. Flex cable shaft length: 4.92' (1.5m)
BW9F0JA-20A**		NEMA 12 flexible shaft handle for BW630 and BW800 frames. Flange mounted. Lockable. Flex cable shaft length: 6.56' (2m)
BW9QNHA		Lockout attachment, use to lock out BW400, BW630 and BW800 series MCCBs. Lock not included.

*Terminal covers are not supplied as standard.

**Terminal covers for line side and load side included with Flange Disconnects. 2/pk

Note: Terminals are factory-installed only. No replacement terminals available.

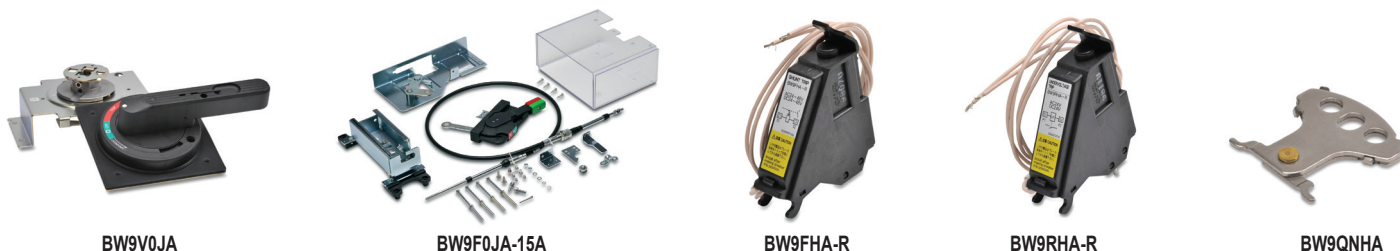

BW9V0JA

BW9F0JA-15A

BW9FHA-R

BW9RHA-R

BW9QNHA

Fuji Molded Case Circuit Breakers 800A Frame Characteristic Curves

BW800 Current Range 700 - 800A

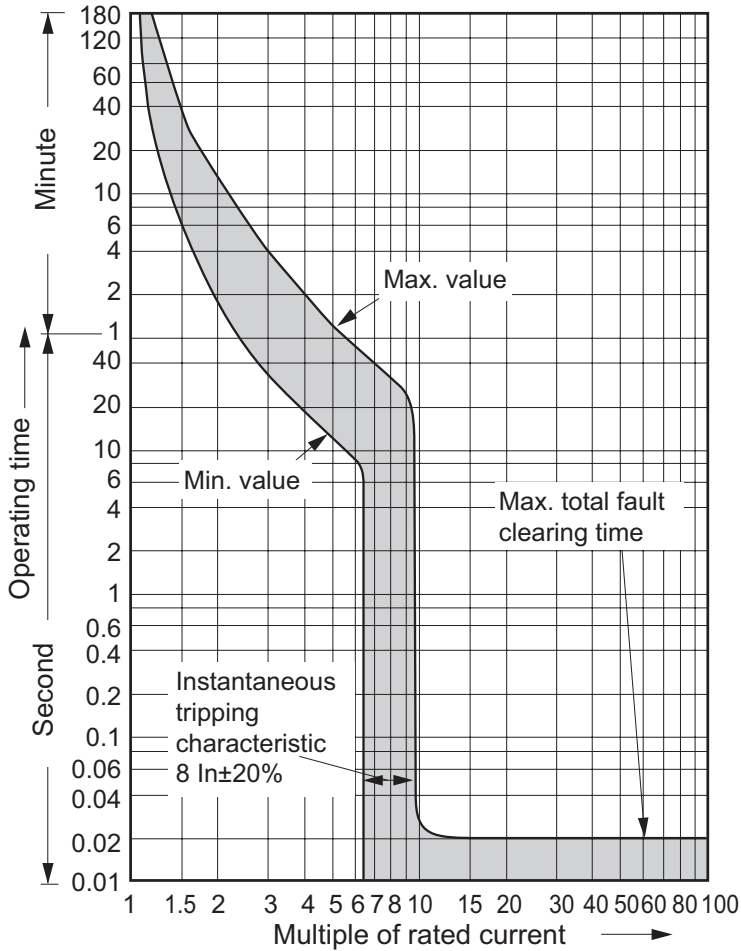

BW800 (Current Range: 700 - 800A)

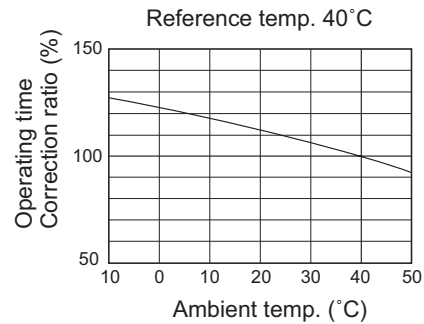

Fuji Molded Case Circuit Breakers Dimensions

Dimensions

mm [inches]

700A BW800 Frame

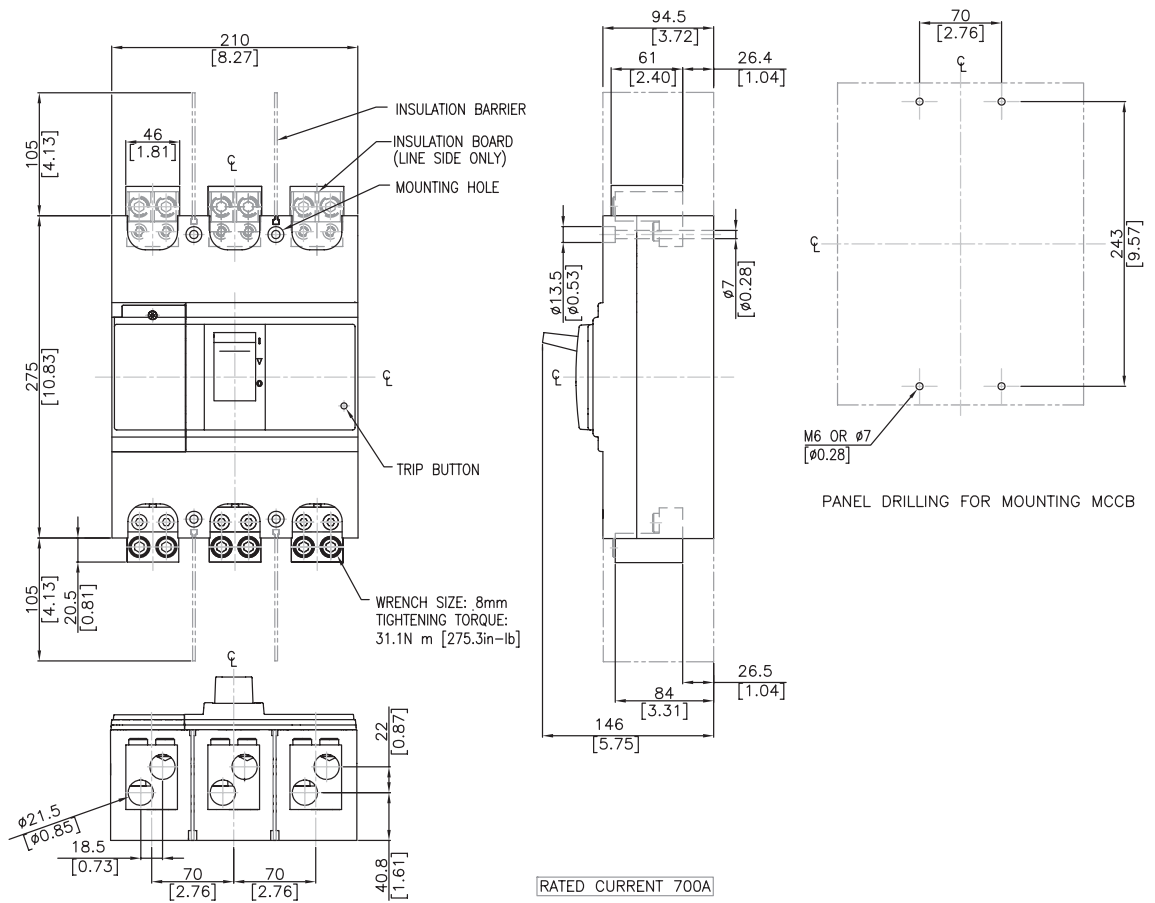

800A BW800 Frame

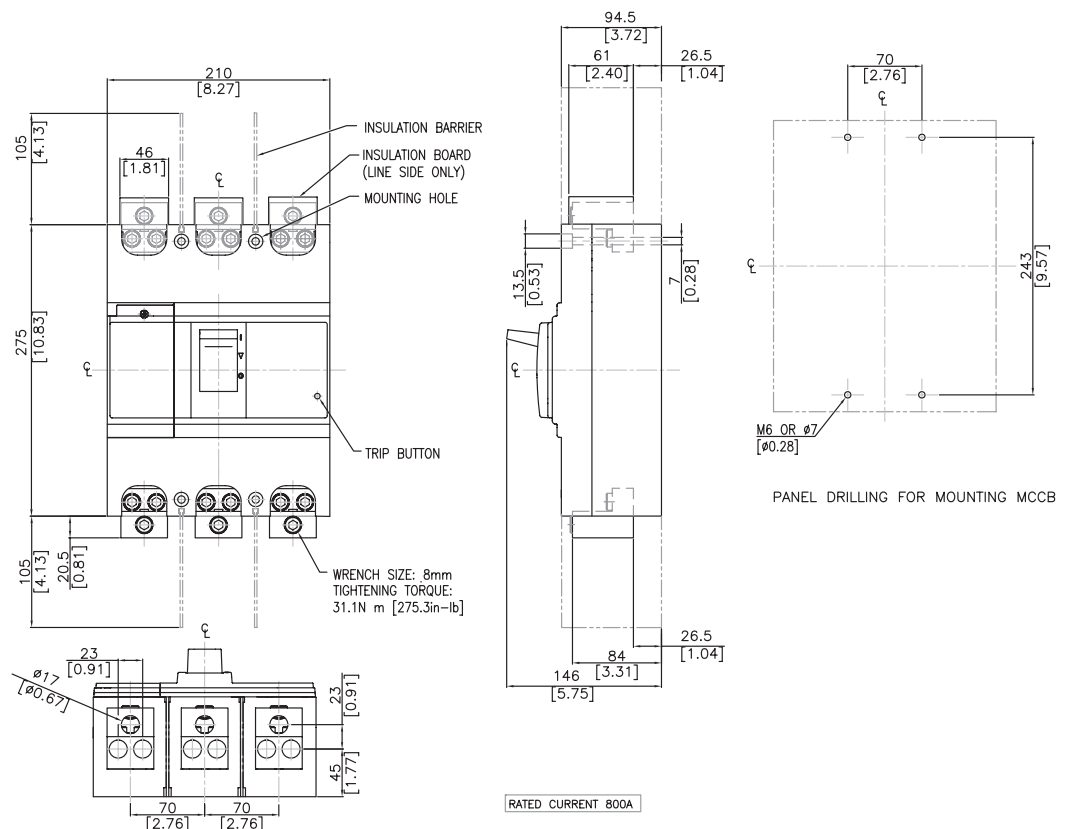

Fuji Molded Case Circuit Breakers Products And Accessory Compatibility

Match the Accessories with Fuji Molded Case Circuit Breakers						
Part Number	Description	BW125JAGU	BW250JAGU	BW400SAGU	BW630RAGU	BW800RAGU
BW9W1SG0	Auxiliary Switch (Mounting Left and right side)	X	X			
BW9W1SHA	Auxiliary Switch (Mounting Left side ONLY)			X	X	X
BW9FRG0	Shunt Trip 24 VAC/VDC (Mounting both Left and Right sides)	X	X			
BW9FHA-R	Shunt Trip 24-48 VAC/VDC (Mounting Left side ONLY)			X	X	X
BW9FAG0	Shunt Trip 100-120 VAC, 100-110 VDC (Mounting both Left and Right sides)	X	X			
BW9FHA-A	Shunt Trip 100-280 VAC, 100-220 VDC (Mounting Left side ONLY)			X	X	X
BW9RGAR	UnderVoltage Release 24VDC (Left side ONLY)	X	X			
BW9RHA-R	UnderVoltage Release 24 VAC/VDC (Left side ONLY)			X	X	X
BW9RGAT	UnderVoltage Release 110-130 VAC (Left side ONLY)	X	X			
BW9RHA-1	UnderVoltage Release 120-130 VAC, 125VDC (Left side ONLY)			X	X	X
BW9SL0CA-3	Replacement Lugs Kit for 125 Amp frame	X				
BW9SL0GA-3	Replacement Lugs Kit for 250 Amp frame up to 175A		X			
BW9SL1GA-3	Replacement Lugs Kit for 250 Amp frame 200A to 250A		X			
BW9V0CA	Rotary Handle	X				
BW9V0GA	Rotary Handle		X			
BW9VSG0	Optional Shaft for BW9V0CA and BW9V0GA, 6.063"	X	X			
BW9VSG0-24	Optional Shaft for BW9V0CA and BW9V0GA, 24"	X	X			
BW9V0HA	Rotary Handle,			X		
BW9V0JA	Rotary Handle,				X	X
BZ-VS2	Optional Shaft for BW9V0HA and BW9V0JA, 3.48"			X	X	X
BZ-VS2-24	Optional Shaft for BW9V0HA and BW9V0JA, H = 24"			X	X	X
BW9F0CA-15A	Flange Handle (flex shaft), NEMA 12, 59" (1.5m) cable, 125 Amp frame	X				
BW9F0CA-20A	Flange Handle (flex shaft), NEMA 12, 78.7" (2.0m) cable, 125 Amp frame	X				
BW9F0GA-15A	Flange Handle (flex shaft), NEMA 12, 59" (1.5m) cable, 250 Amp frame		X			
BW9F0GA-20A	Flange Handle (flex shaft), NEMA 12, 78.7" (2.0m) cable, 250 Amp frame		X			
BW9F0HA-15A	Flange Handle (flex shaft), NEMA 12, 59" (1.5m) cable, 400 Amp frame			X		
BW9F0HA-20A	Flange Handle (flex shaft), NEMA 12, 78.7" (2.0m) cable, 400 Amp frame			X		
BW9F0JA-15A	Nema 12 flexible shaft handle for 630A or 800A frame. 59.06" (1.5m) cable				X	X
BW9F0JA-20A	Nema 12 flexible shaft handle for 630A or 800A frame. 78.74" (2m) cable				X	X
BW9BTHA-L3W	Terminal Cover for the 400A frame			X		
BW9BTJA-L3W	Terminal Cover for the 630A AND 800A frame				X	X
BW9Q1CA	Lockout Attachment 125A and 250A frames	X	X			
BW9QNHA	Lockout Attachment 400A, 630A and 800A frames			X	X	X

Internal Accessory Combinations for BW Series



MCCB	BW125 BW250	BW400 BW630 BW800
Pole	3	3
Auxiliary switch SPDT		
Shunt trip		
Undervoltage trip		
Auxiliary Switch + Shunt Trip		
Undervoltage + Auxiliary Switch		

Fuji Molded Case Circuit Breakers Wire Range Specifications

Wiring

- When connecting the wires, follow NEC (National Electric Code, USA) or CEC (Canadian Electrical code Part 1, Canada) instructions.
- Use copper wire rated for 75°C (167°F) for connecting. UL or CSA approved wire is recommended.
- Tighten the wire connections adequately, as a very large electromagnetic force will be generated when short circuit current is generated.
- Perform additional tightening of the terminal screws periodically.



- Adhere to the allowable number of strands of wire indicated in the table on the left.
- Two wires cannot be connected together to a single connecting hole of lug terminal except BW400SAGU-3P400SB.
- Follow the number of strands of wire indicated on the table. (Wire size and number of wire strands not listed on table can not be connected)
- Do not solder the end of the wire.

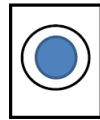

Rated current
15A to 350A



Rated current
400A
3/0 AWG x 2
19 strands each

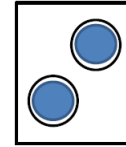

Rated current
500A to 700A

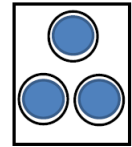

Rated current
800A
300 MCM x 3
37 strands each

Allowable Wire Specifications for Lug Terminals	
Wire Size AWG or MCM (mm ²)	Number of Wire Strands
14 to 2 (2.1 to 33.6)	7
1 to 4/0 (42.4 to 107.2)	19
250 to 500 (127 to 250)	37

Allowable Wire Sizes and Tightening Torque			
Type	Rated Current (A)	Wire Size (AWG or MCM [mm ²])	Tightening Torque
			Lug Terminal*
BW125	15	14 AWG [2.1 mm ²]	51 lb•in [5.8 N•m]
	20	12 AWG [3.3 mm ²]	
	30	10 AWG [5.3 mm ²]	
	40	8 AWG [8.4 mm ²]	
	50	8 AWG [8.4 mm ²]	
	60	6 AWG [13.3 mm ²]	
	70	4 AWG [21.1 mm ²]	
	75	4 AWG [21.1 mm ²]	
	80	4 AWG [21.1 mm ²]	
	90	3 AWG [26.7 mm ²]	
	100	3 AWG [26.7 mm ²]	
BW250	125	1 AWG [42.4 mm ²]	204 lb•in [23 N•m]
	150	1/0 AWG [53.5 mm ²]	
	175	2/0 AWG [67.4 mm ²]	
	200	3/0 AWG [85.0 mm ²]	
	225	4/0 AWG [107.2 mm ²]	
	250	250 MCM [127 mm ²]	
BW400	250	250 MCM [127mm ²]	385 lb•in [43.5 N•m]
	300	350 MCM [177mm ²]	
	350	500 MCM [253mm ²]	
	400	3/0 AWGx2 [85.0 mm ² x2]	282 lb•in [31.9 N•m]
BW630	500	250 MCMx2	275 lb•in [31.07 N•m]
	600	350 MCMx2	
BW800	700	500 MCMx2	275 lb•in [31.07 N•m]
	800	300 MCMx3	

*Lug terminals are supplied as standard.

Note: Terminals are factory-installed only for BW400, BW630 and BW800 series.

No replacement terminals available.

Fuji Molded Case Circuit Breakers Field-mountable Accessories



Rotary Operating Handles for Fuji MCCBs – Selection Guide

Breaker Type	V-type Handle	Price	V-type Handle	With the optional shaft (x = 3.504 (89))		With the optional shaft (x = 24 (609.6))		Mounting Screw	V-type Handle Mass lb. (kg)
			H: inch(mm)	Max. Mounting Depth H: inch(mm)	Range in which the hinge with H can be installed	Max. Mounting Depth H: inch(mm)	Range in which the hinge with H can be installed		
BW400	BW9V0HA		7.48±0.078 (190±2)	9.843±0.078 (250±2)	7.95 to 9.843 (202 to 250)	30.35±0.078 (771±2)	7.95 - 30.35 (202 - 771)	M4 x 3.35 (85)	1.48 (0.67)
BW630 BW800	BW9V0JA								

- Notes:
- Handle is an operating mechanism only; not for sealing enclosure door.
 - Not available for side mounting

Dimensions

mm [inches]

400A, 630A, 800A Frame V type handle

- BW9V0HA, BW9V0JA (BZ-VS2, BZ-VS2-24: optional shafts)

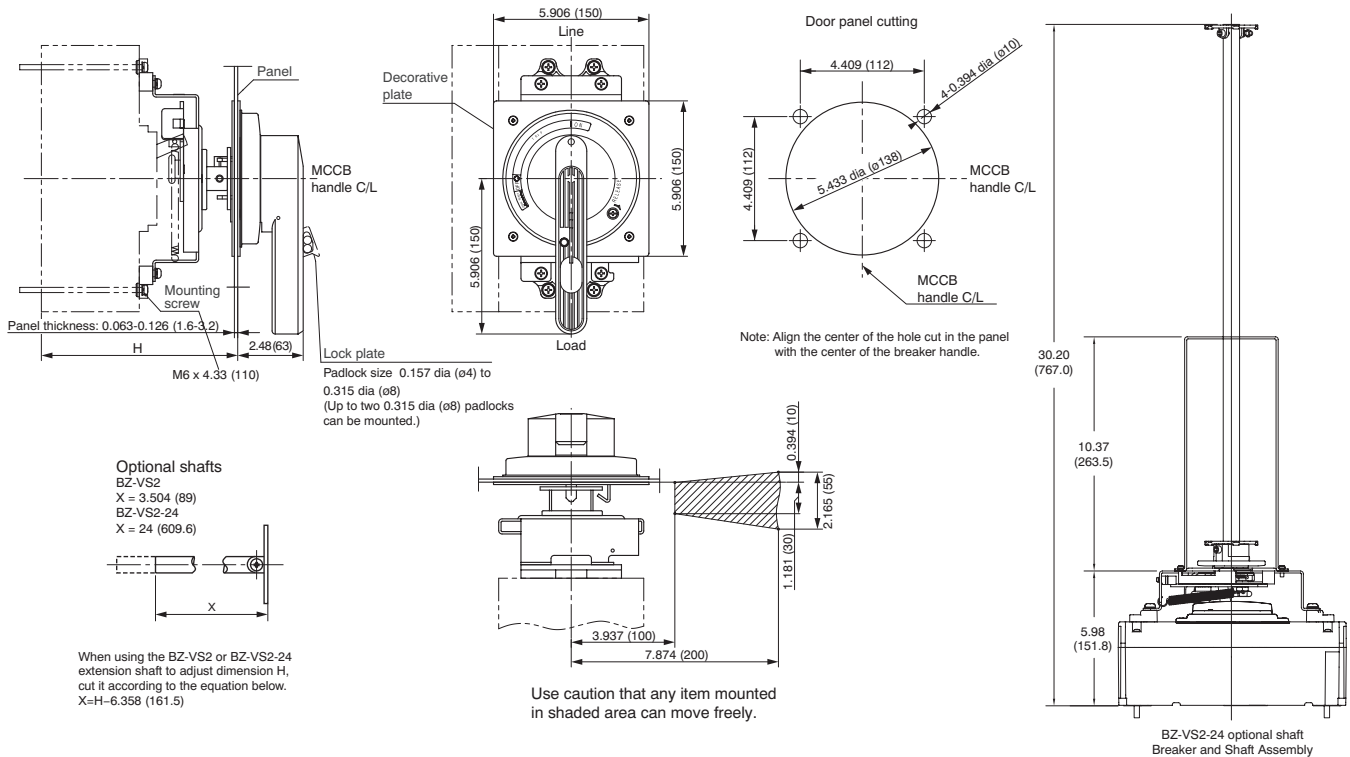

Fuji Molded Case Circuit Breakers Field-mountable Accessories

Defeatable Flexible Handle Operating Mechanisms

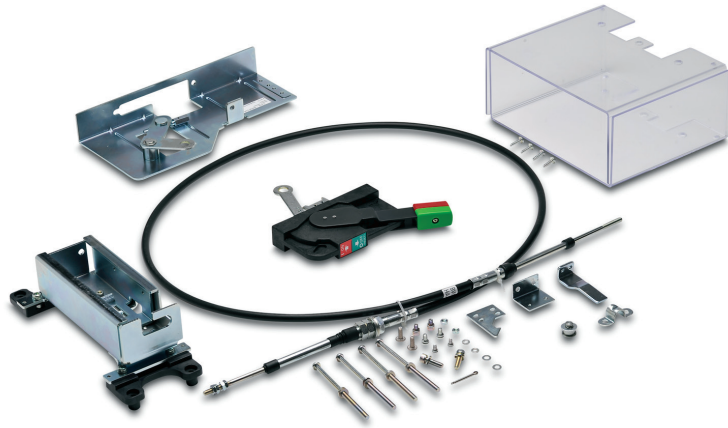

BW9F0JA-20A shown

Flex Shaft Handles for Fuji MCCBs – Selection Guide			
Breaker Type	Handle Type	Price	Description
BW125	BW9F0CA-15A		Nema 12 flexible shaft handle for 125A frame. 59.06" (1.5m)cable
	BW9F0CA-20A		Nema 12 flexible shaft handle for 125A frame. 78.74" (2m) cable
BW250	BW9F0GA-15A		Nema 12 flexible shaft handle for 250A frame. 59.06" (1.5m)cable
	BW9F0GA-20A		Nema 12 flexible shaft handle for 250A frame. 78.74" (2m) cable
BW400*	BW9F0HA-15A		Nema 12 flexible shaft handle for 400A frame. 59.06" (1.5m)cable
	BW9F0HA-20A		Nema 12 flexible shaft handle for 400A frame. 78.74" (2m) cable
BW630* & BW800*	BW9F0JA-15A		Nema 12 flexible shaft handle for 630A or 800A frame. 59.06" (1.5m)cable
	BW9F0JA-20A		Nema 12 flexible shaft handle for 630A or 800A frame. 78.74" (2m) cable

*Terminal covers for line side and load side included with Flange Disconnects. 2/pk

Flex Handle Specifications				
Operating instructions	<ul style="list-style-type: none"> • Operating handle facing up, Breaker is in ON position. • Operating handle facing down, Breaker is in OFF position or is reset. • Panel door cannot be opened when in ON, OFF or Trip position. In order to open the door, the handle must be turned toward reset position. • Release screw is standard. If you want to open a panel door in ON position, please turn the release screw using flat head screwdriver. 			
Frame Size	125A frame	250A frame	400A frame	630A/800 frame
Mechanical Endurance (cycles)	10,000	8,000	6,000	6,000
Ambient Temperature	14 to 140F (- 10 to 40°C)			
Relative Humidity	less than 95% RH			
Protection	NEMA Type12 IP54 (IEC60529)			
Conforming Standards	NFPA 79(2007), ANSI(Lockout), OSHA(1910.147, Lockout/tagout), UL489(cUL)			
Environment	No excessive dust, smoke, corrosive gases, flammable gases, steam or salt.			

Fuji Molded Case Circuit Breakers Field-mountable Accessories

Dimensions

mm [inches]

BW9F0HA

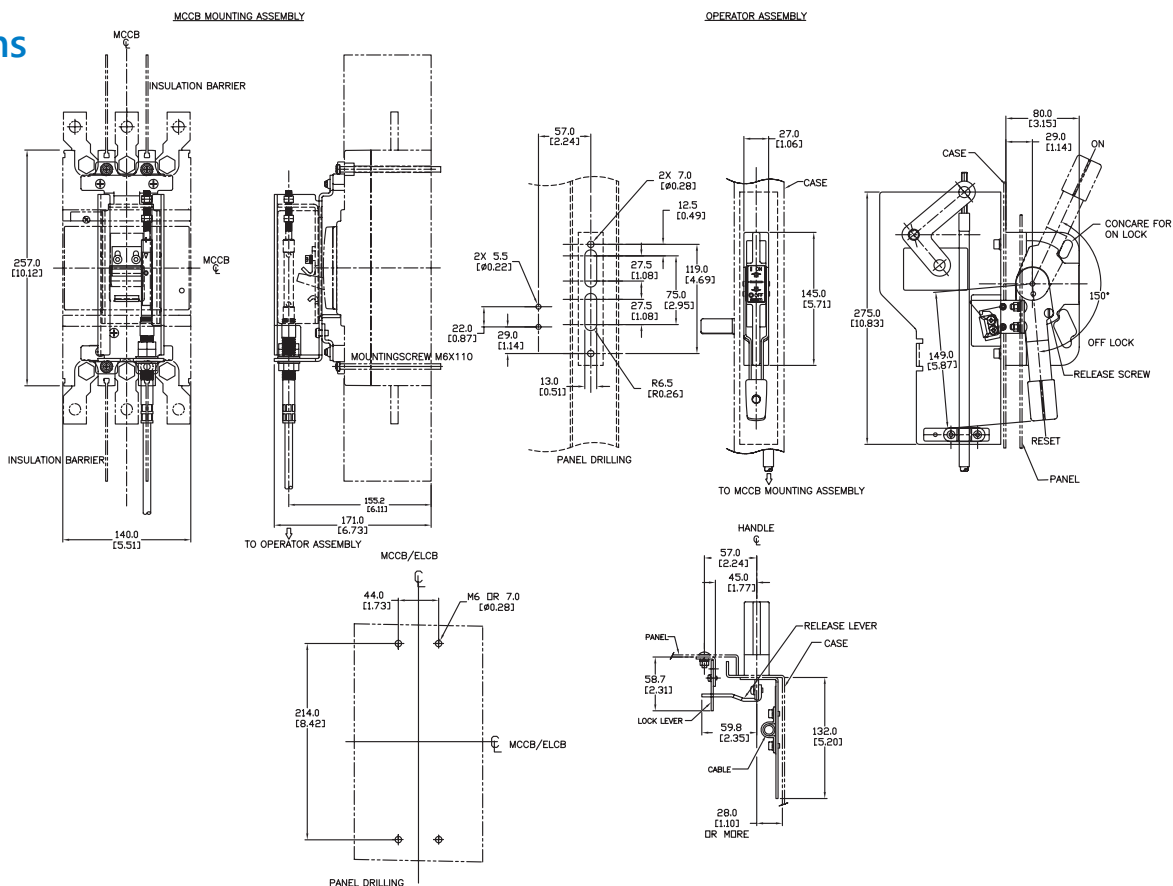

BW9F0JA

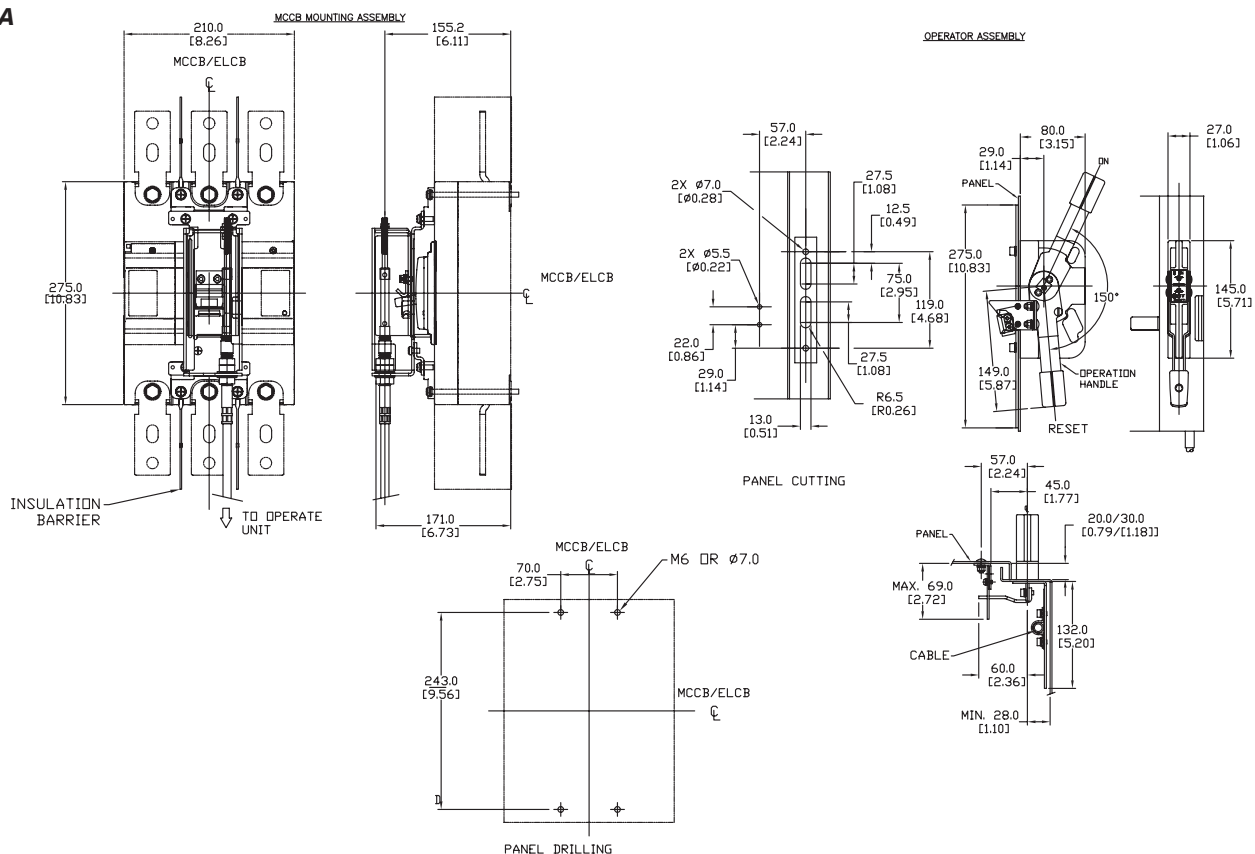

Fuji Molded Case Circuit Breakers Accessories



Auxiliary Contacts

The auxiliary contacts are accessory contacts for the indication of circuit breaker open-closed or tripped.



BW9W1SHA shown

Auxiliary Contacts for Fuji MCCBs – Selection Guide			
Breaker Type	Part Number	Price	Description
BW125 BW250	BW9W1SG0		Auxiliary switch for for 125A and 250A frame. Mounting left and right side
BW400 BW630 BW800	BW9W1SHA		Auxiliary switch for for 400A , 630A and 800A frame. Mounting left side ONLY

Ratings of Auxiliary Switches

Standard Type								
Breaker Type	Rated Thermal Current (A)	Make/Break Current (A)						Minimum Load Current
		AC			DC			
		Voltage (V)	Res. Load	Ind. Load	Voltage (V)	Res. Load	Ind. Load	
BW125, BW250, BW400 BW630, BW800	5	24	5	5	24	4	3	5V DC 160 mA
		48	5	5	48	2.5	1	
		125	5	3	125	0.4	0.4	30V DC 30 mA
		250	3	2	250	0.2	0.2	

Operation of auxiliary switches

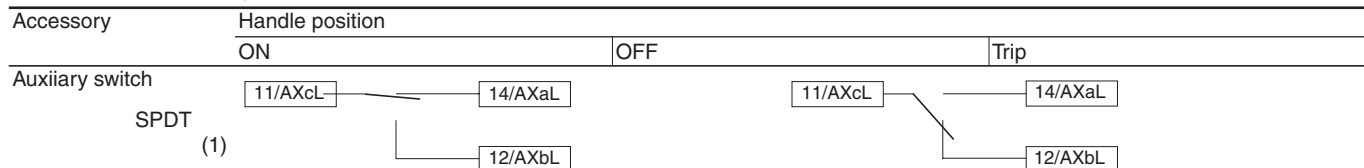

Shunt Trips

Shunt Trip is for remote tripping (opening) of circuit breaker.

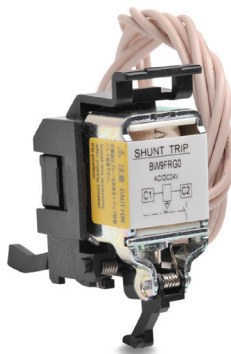

BW9FRG0 shown

Shunt Trips for Fuji MCCBs – Selection Guide		
Part Number	Price	Description
BW9FRG0		Field installable 24 VAC/VDC shunt trip for BW125 and BW250 series MCCB. Left and right side mounting. Lead wires 20AWG, 19.69" long.
BW9FHA-R		Field installable 24/48 VAC/VDC shunt trip for BW400, BW630 and BW800 series MCCB. Left side mounting only. Lead wires 20AWG, 19.69" long.
BW9FAG0		Field installable 100/120 VAC, 100-110 VDC shunt trip for BW125 and BW250 series MCCB. Left and right side mounting. Lead wires 20AWG, 19.69" long.
BW9FHA-A		Field installable 100/240 VAC, 100-220 VDC shunt trip for BW400, BW630 and BW800 series MCCB. Left side mounting only. Lead wires 20AWG, 19.69" long.

Ratings of Shunt Trips

Breaker Type	AC		DC		Time Rating of Coil (with 1 N.O. contact to prevent coil burnout)	Operating Time (ms)
	Voltage (V)	VA	Voltage (V)	W		
BW125, BW250	24	50	24	50	Continuous	13-21
	100-120	50	100-110	50		
BW400, BW630, BW800	24-48	2	24-48	2	Continuous	8-20
	100-240	3	100-220	3		

Note: Allowable operating voltage AC voltage: 85% to 110% of coil rated voltage
DC voltage: 75% to 125% of coil rated voltage

Fuji Molded Case Circuit Breakers Accessories



Undervoltage Releases

Undervoltage Release will trip the circuit breaker when the connected voltage drops to less than 70% of undervoltage release voltage rating. It will allow the circuit breaker to close (ON) when voltage is approximately 85% of rated voltage.

Undervoltage Releases for Fuji MCCBs – Selection Guide			
Breaker Type	Part Number	Price	Description
BW125, BW250	BW9RGAR		Undervoltage Release 24V DC (Left side ONLY)
BW125, BW250	BW9RGAT		Undervoltage Release 110 to 130 VAC VAC/VDC (Left side ONLY)
BW400, BW630, BW800	BW9RHA-R		Undervoltage Release 24 VAC/VDC (Left side ONLY)
BW400, BW630, BW800	BW9RHA-1		Undervoltage Release 120 to 130 VAC 125 VDC (Left side ONLY)



BW9RGAR shown

Ratings of Undervoltage Trip				
Breaker Type	AC		DC	
	Voltage (V)	VA	Voltage (V)	W
BW125*1 BW250*1	–	–	24	5
	110 - 130	5	–	–
BW400*2 BW630*2 BW800*2	24	2	24	2
	120 - 130	3	125	3

Note: Allowable operating voltage: AC voltage: 85% to 110% of coil rated voltage
DC voltage: 75% to 125% of coil rated voltage.

*1 Reset-allowed type: When the breaker handle is in the OFF or RESET state, tripping does not occur, even if the undervoltage trip coil is not energized.

Turning ON with the undervoltage trip coil not energized causes normal tripping.

*2 Reset-prohibited type: When the undervoltage trip coil is not energized, reset operation cannot reset the tripped breaker to the OFF state.



BW9SL0GA-3 shown

Replacement Lugs

Replacement Lug Kits for Fuji MCCBs – Selection Guide		
Part Number	Price	Description
BW9SL0CA-3		Replacement lug kit for BW125 series MCCB. 75°C. Cu only Package of 3
BW9SL0GA-3		Replacement lug kit for BW250 series up to 175A MCCB. 75°C. Cu only Package of 3
BW9SL1GA-3		Replacement lug kit for BW250 MCCB series 200A to 250A. 75°C. Cu only Package of 3

Note: Terminals are factory-installed only for BW400, BW630 and BW800 series. No replacement terminals available.

Fuji Molded Case Circuit Breakers Accessories



Terminal Covers

Terminal covers act as guards to shield the operator from touching live terminations. They fit either the line or load side.



BW9BTHA-L3W shown

Terminal Covers for Fuji MCCBs – Selection Guide						
Breaker Type	Part Number	Price	Description	Dimensions inch (mm)		
				A	B	C
BW400	BW9BTHA-L3W		Gray-white Long type terminal cover for Fuji MCCBs. For line side and load side. 2/pk	6.772 (172)	4.331 (110)	3.858 (98)
BW630, BW800	BW9BTJA-L3W		Gray-white Long type terminal cover for Fuji MCCBs. For line side and load side. 2/pk	8.268 (210)	6.102 (155)	3.858 (98)

Note: Gray-white short type terminal covers are provided with breakers as standard for 125 and 250 Amp frames.

Dimensions of Terminal Covers: inch (mm)

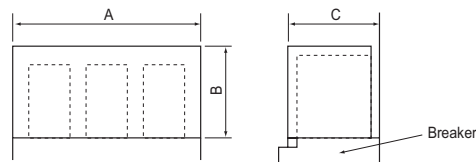

Lockout Attachment

Lockout Attachments for Fuji MCCBs – Selection Guide			
Breaker Type	Part Number	Price	Description
BW125 BW250	BW9Q1CA		Use to lock out BW125 and BW 250 series MCCBs. Lock not included
BW400, BW630, BW800	BW9QNHA		Use to lock out BW400, BW600 and BW800 MCCBs. Lock not included.



BW9Q1CA shown