

Hammond Transformers



Imperator

Fortress

Spartan

Get years of reliable service from a quality transformer at a practical price

HPS Imperator™ control transformers for industrial applications

HPS Imperator control transformers from Hammond are designed for high inrush applications requiring reliable output voltage stability. Designed for industrial applications where electromagnetic devices such as relays, solenoids, etc. are used, they maximize inrush capability and output voltage regulation when electromagnetic devices are initially energized.

HPS Imperator control transformers use Mylar, Nomex and other high-quality insulating materials to electrically insulate turn-to-turn windings, layer-to-layer windings, primary-to-secondary windings and ground. These transformers are vacuum impregnated with VT polyester resin and oven-cured, which seals the surface and eliminates moisture. Filling the entire unit provides a strong mechanical bond and offers protection from the environment. This design utilizes superior insulation systems and is constructed with high quality silicon steel laminations, which provide optimum performance and reliability.

The custom injection-molded cover, with its unique fin-shaped design, provides excellent cooling properties while protecting the coils and terminations from moisture, dirt and other industrial airborne contaminants.

The heavy steel mounting feet are welded to the core, providing maximum strength and low noise in a compact design.

The HPS Imperator's unique terminal block design (patent pending) allows for the quick and easy installation of standard secondary or optional primary 1 3/32" x 1 1/2" midget/type CC fuse clips on every unit. This is the simplest and most inexpensive fusing installation provided on any industrial control transformer in the market today.

The windings and internal terminations of the HPS Imperator are encapsulated, which protects them from moisture, dirt and other airborne contaminants. The custom molded coil covers with their unique fin-shaped design combine superior transformer cooling properties with a clean bold look.

The HPS Imperator utilizes custom serrated terminals in combination with standard SEMS washer screws for easier assembly and quicker installation as well as superior connection strength when connecting with bare, solid, or stranded wire. It also allows for ring or spade termination connectors with a maximum width of 0.37 in (9.4 mm).

HPS Fortress™ commercial potted transformers

The HPS Fortress commercial potted transformers provide an innovative design with commercial applications where quality, ease of installation, and low cost are key.

All Fortress units are encapsulated with electrical grade silica sand and resin compounds, which completely enclose the core and coil to seal out moisture, airborne contaminants and eliminates corrosion and deterioration.

HPS Spartan™ open core and coil control transformers

The HPS Spartan line of industrial open-style control transformers is ideally suited for general purpose, industrial and light duty loads.

Designed for applications with lower inrush and where less demanding environmental protections are needed, HPS Spartan models offer an efficient and economical solution. They feature molded terminal blocks up to 3000VA or 30A. Optional finger guards and a fuse block adapter kit are available.

Superior quality and value

- Compact, efficient design
- Easy installation and hook-up
- Inexpensive while maintaining superior quality in materials and workmanship
- Wall mounting

Applications

- Lighting
- Motor control circuits
- HVAC
- Signal and alarm systems
- Circuit isolation
- Schools
- Office buildings

HPS Fortress™ Commercial Encapsulated Transformers



Features

Totally enclosed to seal out moisture and airborne contaminants

Easily accessible nameplate

Installation is made quick and easy with keyhole mounting slots



All units are encapsulated with an electrical grade silica sand and resin compound

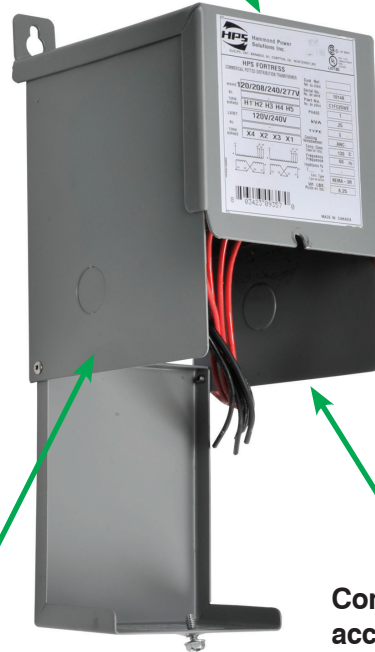

NEMA 3R enclosure meets or exceeds listing criteria including NEMA and ANSI standards for indoor and outdoor applications



Conduit knockouts and an easily accessible wiring compartment



Voltage Regulation

Voltage regulation in transformers is the difference between the “No-Load voltage” and the “Full-Load voltage”. This is expressed in terms of percentage.

$$\text{Regulation Percentage} = \frac{E_{\text{No-Load}} - E_{\text{Full Load}}}{E_{\text{Full Load}}} (100\%)$$

The secondary voltage (nominal) listed in these pages are at Full-Load, meaning the point at which the transformer is operating at maximum permissible secondary current. No-Load voltage can increase 6 to 10% max.

Warning: Secondary voltages of transformers may damage some loads. For example, a transformer connected as 480/120 Volt but applied 495 Volt primary can produce at No-Load a voltage of 134 Volts which will damage the inputs of a PLC D0-06AA, whose maximum input voltage is 132 Volt. Notice that the current of D0-06AA input is 10mA, making it very close to No-Load.

HPS Fortress™ Commercial Encapsulated Transformers

Primary 480**/440/416/400/380 x 240**/220/208/200/190VAC

Secondary 240 x 120 VAC



Features

- **Ratings:** Single phase from 0.25kVA to 5kVA; 50/60 Hz**
- **Electrostatic Shield:** Standard on all single phase units 0.75kVA and larger
- **Quality Design:** All units are encapsulated with electrical grade silica sand and resin compounds which completely enclose the core and coil to seal out moisture, airborne contaminants and eliminates corrosion and deterioration.
- **Insulation:** Offering UL class 130°C (266°F) insulation, 95°C (203°F) temperature rise up to 1kVA on single phase; 180°C (356°F) insulation, 135°C (275°F) temperature rise on all units over 1kVA on single phase. Quiet operation with sound levels below NEMA standards.
- **Enclosures:** NEMA 3R enclosures meet or exceed listing criteria including NEMA, ANSI, and OSHA standards for indoor and outdoor service.
- **Rear and side entry conduit knockouts** into an easily accessible and roomy wiring compartment.
- **Wiring compartment:** Provides tinned copper lead wire terminations and standard ground lug assembly for easy cable installation.
- **Taps are convenient** to select output voltage.
- **Output voltage adjustable** by taps.
- **Temperature Range:** -20°C (-4°F) to average ambient temperature 30°C (86°F), not to exceed 40°C (104°F)

- **Installation made quick and easy:** All encapsulated transformers are designed for wall mounting and include keyhole mounting slots.
- **10 year warranty** (limited to mfg. defects)

Agency Approvals

- UL Listed File No. E50394 (Type Q)
- CSA File No. LR3902 (Type Q)
- CE
- RoHS



C1FC25XE



C1F1C0XES



C1F005XES

HPS Fortress Encapsulated Transformer Specifications									
Part Number	Price	kVA Rating	Primary Voltage (50/60Hz)**	Secondary Voltage (Nominal)	Output Current (Amps) 120/240	Impedance %		Total Heat Dissipation (Watts)*	Product Wt/Lbs
						VA	%z		
C1FC25XE		0.25	190/200/208/ 220/240 x 380/400/416/ 440/480	120/240	2.08/1.04	250	13.0	76	8.25
C1FC50XE		0.50			4.16/2.08	500	10.7	95	14.0
C1F1C0XES		1.0			8.33/4.16	1000	5.4	110	26.0
C1F002XES		2.0			16.67/8.33	2000	4.5	140	52.0
C1F003XES		3.0			25.0/12.5	3000	4.3	145	65.0
C1F005XES		5.0			41.67/20.83	5000	4.3	351	115.0

* Heat dissipation calculated based on full rated load on transformer.

** The primary voltage ratio of 240 or 480 is available at 60Hz only with a secondary voltage of approximately 130/262V

HPS Fortress™ Commercial Encapsulated Transformers

Primary 480/440/416/400/380 x 240/220/208/200/190 VAC

Secondary 240 x 120 VAC



Dimensions

Figure A - 250VA to 2kVA

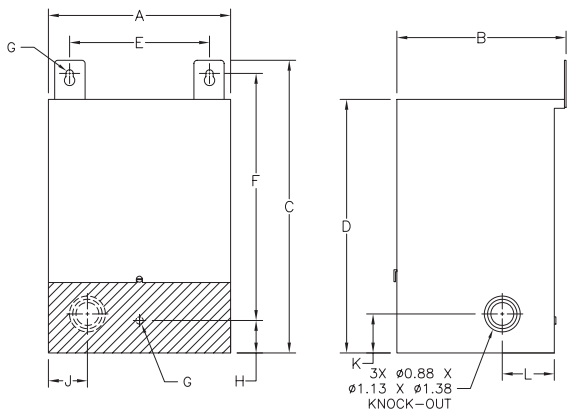
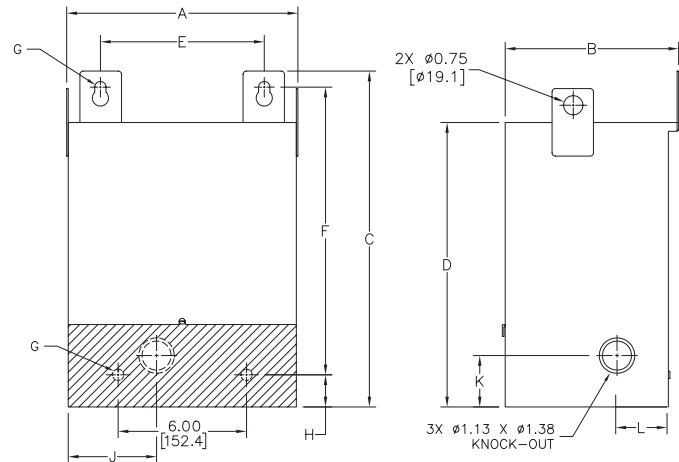

Figure B - 3kVA to 5kVA



* Front bottom panel is hinged for access to terminals, shaded areas show view of rear mounting holes and knockout.

Dimensions inches [mm]

HPS Fortress Encapsulated Transformer Dimensions												
Part Number	Mtg. Fig.	Overall Dimensions in (mm)				Mounting Holes in (mm)		Mounting Hole Dia. in (mm)	Knock Out Dimensions in (mm)			
		A	B	C	D	E	F	G	H	J	K	L
C1FC25XE	A	3.75 (95.3)	5.25 (133.4)	7.25 (184.2)	6.25 (158.8)	2.50 (63.5)	5.63 (143.0)	0.22 (5.6)	1.25 (31.8)	N/A	1.50 (38.1)	2.00 (50.8)
C1FC50XE	A	4.50 (114.3)	5.75 (146.1)	7.25 (184.2)	6.25 (158.8)	3.13 (79.5)	5.63 (143.0)	0.22 (5.6)	1.25 (31.8)	0.81 (20.6)	1.50 (38.1)	2.00 (50.8)
C1F1C0XES	A	5.88 (149.4)	5.50 (139.7)	10.00 (254.0)	8.50 (215.9)	4.13 (104.9)	8.25 (209.6)	0.28 (7.1)	1.25 (31.8)	1.25 (31.8)	1.50 (38.1)	2.00 (50.8)
C1F002XES	A	7.00 (177.8)	6.50 (165.1)	11.75 (298.5)	10.25 (260.4)	5.38 (136.7)	9.50 (241.3)	0.28 (7.1)	1.25 (31.8)	1.50 (38.1)	15.0 (381.0)	2.00 (50.8)
C1F003XES	B	10.00 (254.0)	7.75 (196.9)	17.25 (438.2)	15.25 (387.5)	7.38 (187.5)	15.38 (390.7)	0.44 (11.2)	1.25 (31.8)	4.00 (101.6)	2.00 (50.8)	2.00 (50.8)
C1F005XES	B	10.00 (254.0)	7.75 (196.9)	17.25 (438.2)	15.25 (387.5)	7.38 (187.5)	15.38 (390.7)	0.44 (11.2)	1.25 (31.8)	4.00 (101.6)	2.00 (50.8)	2.00 (50.8)

Note: All dimensions have a tolerance of ±0.06 inches unless otherwise noted.
 To provide NEMA 3R protection (protection from falling rain), the transformer must be mounted vertically with the mounting tabs facing up.
 Additional information in installation insert.

HPS Fortress™ Commercial Encapsulated Transformers

Primary 480/440/416/400/380 x 240/220/208/200/190 VAC

Secondary 240 x 120 VAC



Wiring Diagram - For 250VA to 2kVA

SCHEMATIC	CONNECTIONS		
	Primary Volts	Connect lines to	Inter-connect
	480 (60Hz)	H1, H10	H5-H6
	440 (50/60Hz)	H1, H10	H5-H6
	416 (50/60Hz)	H1, H9	H4-H6
	400 (50/60Hz)	H1, H8	H3-H6
	380 (50/60Hz)	H1, H7	H2-H6
	240 (60 Hz)	H1, H10	H1-H6, H5-H10
	220 (50/60Hz)	H1, H10	H1-H6, H5-H10
	208 (50/60Hz)	H1, H9	H1-H6, H4-H9
	200 (50/60Hz)	H1, H8	H1-H6, H3-H8
	190 (50/60Hz)	H1, H7	H1-H6, H2-H7
<th>Secondary Volts</th> <th>Connect lines to</th> <th>Inter-connect</th>	Secondary Volts	Connect lines to	Inter-connect
	240	X1, X4	X2-X3
	120/240 120	X1, X2, X4 X1, X4	X2-X3 X2-X4, X1-X3

Wiring Diagram - For 3kVA and 5kVA

SCHEMATIC	CONNECTIONS		
	Primary Volts	Connect lines to	Inter-connect
	440 or 480	H1, H2	1-2
	416	H1, H2	2-3
	400	H1, H2	3-4
	380	H1, H2	4-5
	220 or 240	H1, H2	5-6
	208	H1, H2	6-7
	200	H1, H2	7-8
	190	H1, H2	H1-2, H2-1
		H1, H2	H1-4, H2-3
		H1, H2	H1-6, H2-5
	H1, H2	H1-8, H2-7	
<th>Secondary Volts</th> <th>Connect lines to</th> <th>Inter-connect</th>	Secondary Volts	Connect lines to	Inter-connect
	240	X1, X4	X2- X3
	120 120/240	X1, X2 X1, X2, X4	X2-X4, X1-X3 X2-X3

Termination*		
Part No.	HV	LV
C1FC25XE	#18 AWG Leads	#18 AWG Leads
C1FC50XE	#18 AWG Leads	#18 AWG Leads
C1F1C0XES	#18 AWG Leads	#14 AWG Leads
C1F002XES	#14 AWG Leads	#14 AWG Leads
C1F003XES	#14 AWG Leads	#14 AWG Leads
C1F005XES	#14 AWG Leads	#12 AWG Leads

* Transformers are provided with copper leads.