

IDEM Non-Contact RFID Locking Safety Switches

MGL Series – Stainless Steel Housing



- Heavy duty or medium duty holding force models available
- Master coded or uniquely coded actuation
- RFID provides a high degree of anti-tamper, virtually impossible to override
- Flexible actuator for a high degree of misalignment tolerance.
- Able to connect to most popular safety relays to achieve up to PLe and Cat.4 for ISO3849-1
- Ability to connect up to 20 switches and E-stops in series
- IP69K rating for food processing applications
- Choice of 8-wire cable or M12 quick connect (purchase cables separately for the M12 QC)
- Remanence magnetization acts as a light magnetic latch after unlocking.
- (2) N.C. (door closed - lock energized) Safety outputs, overload protected
- (1) N.O. Auxiliary output for indication of door open
- Includes both switch and actuator



IDEM Non-Contact RFID Locking Switch Sets - Stainless Steel									
Part Number	Price	Body Material	Weight (lbs)	Holding Force	Operating Voltage	Operating Current	Coding	Connection Type	Dimensions
Heavy Duty Holding Force									
<u>MGL-1SS-U-462001</u>		316 stainless steel	5.73	1200N (269.8 lbf)	24VDC ± 10%	Nominal ≈ 50mA	Uniquely Coded	5-meter (16.48 ft.) cable	Figure 1
<u>MGL-1SS-U-462003</u>			5.20					8-pin M12 quick-disconnect	
<u>MGL-1SS-M-462004</u>			5.73			Locked ≈ 500mA	Master Coded	5-meter (16.48 ft.) cable	
<u>MGL-1SS-M-462006</u>			5.20					8-pin M12 quick-disconnect	
Medium Duty Holding Force									
<u>MGL-2SS-U-460001</u>		316 stainless steel	3.84	600N (134.9 lbf)	24VDC ± 10%	Nominal ≈ 50mA	Uniquely Coded	5-meter (16.48 ft.) cable	Figure 2
<u>MGL-2SS-U-460002</u>			4.42					10-meter (32.8 ft.) cable	
<u>MGL-2SS-U-460003</u>			3.31					8-pin M12 quick-disconnect	
<u>MGL-2SS-M-460004</u>			3.84			Locked ≈ 500mA	Master Coded	5-meter (16.48 ft.) cable	
<u>MGL-2SS-M-460006</u>			3.31					8-pin M12 quick-disconnect	

IDEM Non-Contact RFID Locking Switches Replacement Actuators - Stainless Steel						
Part Number	Price	Body Material	Weight (lb)	Holding Force	Coding	Dimensions
<u>MGL-1SS-M-462102*</u>		316 stainless steel	1.87	1200N (269.8 lbf) - Heavy Duty	Master Coded	Figure 1
<u>MGL-2SS-M-460102*</u>			1.21	600N (134.9 lbf) - Medium Duty		Figure 2

* For use with Stainless Steel Master Coded models only

IDEM Non-Contact RFID Locking Safety Switches

Dimensions

mm [in]

Figure 1

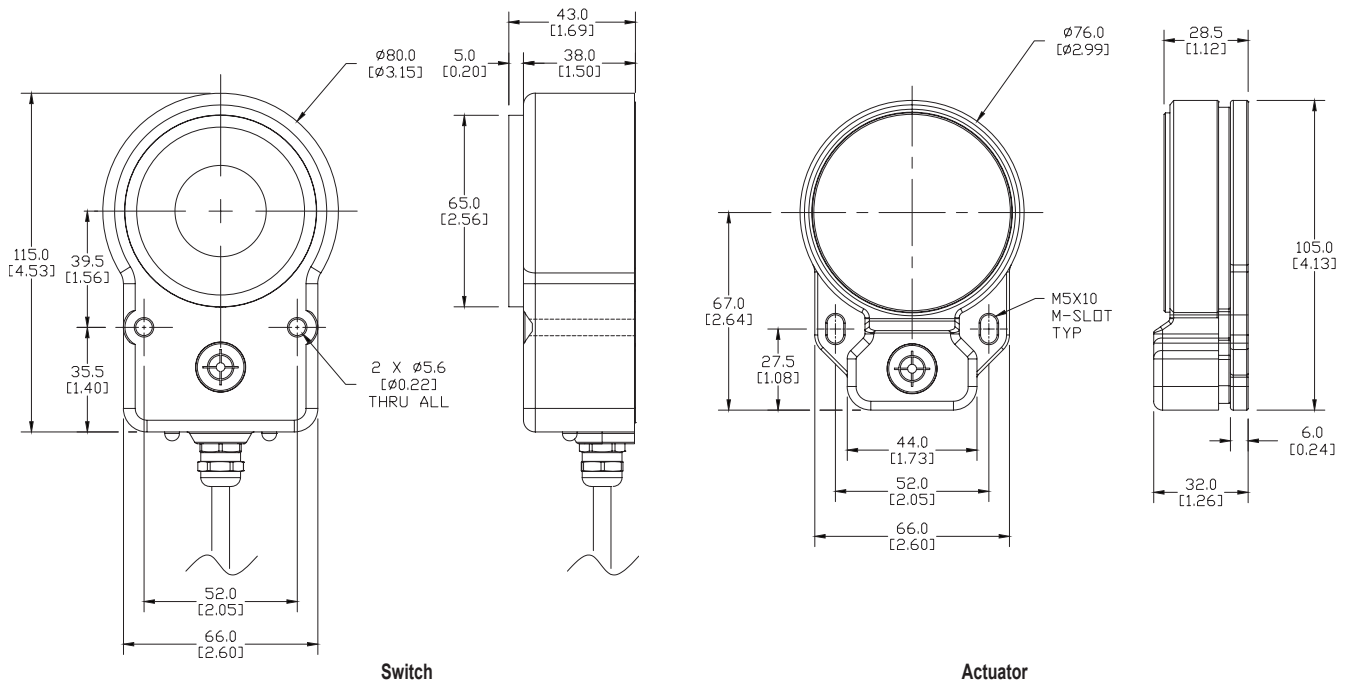

MGL-1SS

Figure 2

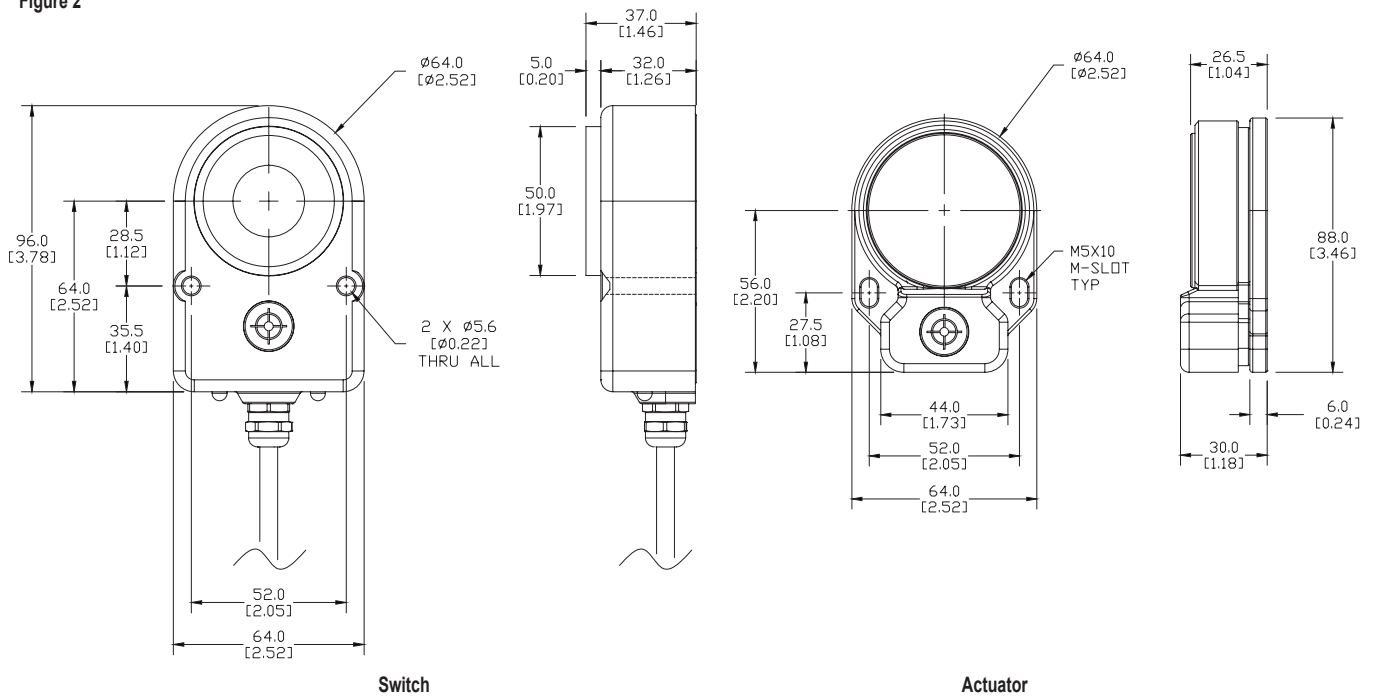

MGL-2SS

IDEM Non-Contact RFID Locking Safety Switches Specifications

IDEM Non-Contact RFID Locking Switches Specifications			
	MGL-1SS / MGL-2SS	MGL-1M / MGL-2M	MGL-1P / MGL-2P
Body Material	316 Stainless Steel	Die Cast Metal	High Specification Polyester Plastic
Safety Classification and Reliability Data			
Minimum Switched Current	1mA @ 10VDC		
Dielectric Withstand	250VAC		
Insulation Resistance	100 Mohms		
Switching Distance	Sao (Sensing Assured Operating) – 1mm close Sar (Sensing Assured Release) – 10mm open		
Tolerance to Misalignment	5mm in any direction from 5mm setting gap		
Switching Frequency	1.0 Hz maximum		
Approach speed	200 mm/s to 1000 mm/s		
Temperature Range	-25°C to 40°C (-13°F to 104°F)		
Enclosure Protection	IP69K	IP67	
Cable Type	PVC, 8-wire, 6mm OD		
Mounting Screws	2 x M5 – Tightening torque 1Nm (0.74 lb-ft)		
Mounting Position	Any		
Characteristic Data According to IEC62061 (used as a sub system)			
Safety Integrity Level	SIL3		
PFH (1/h)	4.77E-10 Corresponds to 4.8% of SIL3		
PFD	4.18E-05 Corresponds to 4.2% of SIL3		
Proof Test Interval T1	20 years		
Characteristic Data according to EN ISO13849-1*			
Performance Level	e If both channels are used in combination with a SIL3/PLe control device		
Category	Cat4		
MTTFd	1100 years		
Diagnostic Coverage DC	99% (high)		
Number of operating days per year	dop = 365d		
Number of operating hours per day	hop = 24h		
B10d	Not mechanical parts implemented		

*Note: When the product is used differently from these assumptions (different load, operating frequency, etc.) the values must be adjusted accordingly.

IDEM Non-Contact RFID Locking Safety Switches

The MGL series RFID locking switches use two LEDs to indicate all the possible switch states.

The LEDs are in a clearly visible location on either side of the cable exit point.

IDEM Non-Contact RFID Locking Switches LED Operation and Switch Status Indication			
Switch Status	Guard	Green LED	Yellow LED
Locked	Closed	Steady	Off
Solenoid Power OFF (Unlocked)	Closed	Flashing	Off
Guard Open	Open	Off	Steady
Door Forced Open	Open	Off	Flashing
Wrong Actuator Code	Closed	Flashing	Flashing

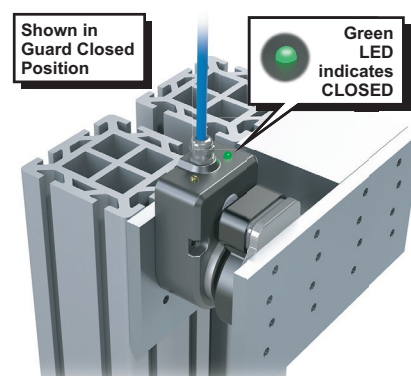
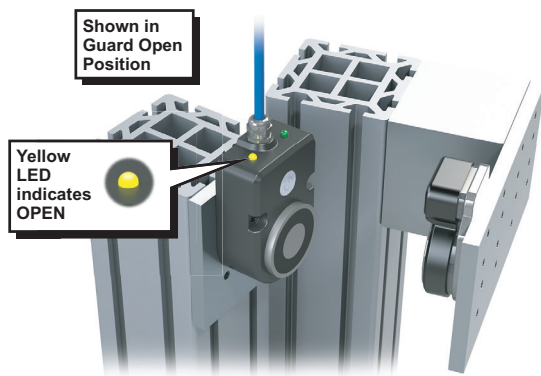

Connection Colors

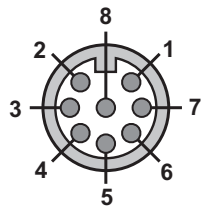

Pin View from Switch



IDEM Non-Contact RFID Locking Switches Wiring Diagram			
Quick Connect (QC) M12 8-way male plug	Conductor Colors	Function	Power Rating
8	Orange	Lock Applied (24VDC ± 10%)	500mA Max.
5	Brown	Auxiliary Signal	+24VDC
4	Yellow	Safety Output 2	200mA Max.
6	Green	Safety Output 2	
1	White	Safety Output 1	200mA Max.
7	Black	Safety Output 1	
3	Blue	0VDC	50mA Max.
2	Red	+ 24VDC ± 10%	

Note: For M12 Quick Connect switches, color code may vary depending on the cable used. Please verify before installation.

Safety Products



Warning: Safety products sold by AutomationDirect are Safety components only. The purchaser/installer is solely responsible for the application of these components and ensuring all necessary steps have been taken to assure each application and use meets all performance and applicable safety requirements and/or local, national and/or international safety codes as required by the application. AutomationDirect cannot certify that our products, used solely or in conjunction with other AutomationDirect or other vendors' products, will assure safety for any application. Any person using or applying any products sold by AutomationDirect is responsible for learning the safety requirements for their individual application and applying them, and therefore assumes all risks, and accepts full and complete responsibility, for the selection and suitability of the product for their respective application.

AutomationDirect does not provide design or consulting services, and cannot advise whether any specific application or use of our products would ensure compliance with the safety requirements for any application.