

General Accessories for AC Drives

Drives Accessories – Line/Load Reactors

LR(2) Series Line Reactors

Input line reactors protect the AC drive from transient overvoltage conditions typically caused by utility capacitor switching. Input line reactors also reduce the harmonics associated with AC drives and are recommended for all installations.

Output line (load) reactors protect the motor insulation against AC drive short circuits and IGBT reflective wave damage, and also allow the motor to run cooler by “smoothing” the motor current waveform. They are recommended for operating “non-inverter-duty” motors, and for any motors where the length of wiring between the AC drive and motor is less than 100 feet. For AC Drive-to-Motor wiring distances over 100 feet, use of the VTF series output filter is recommended.

Features:

- Universal mounting feet with multiple mounting slots; can replace most reactors using existing mounting holes
- Short-term overload rating: 200% of rated current for 3 minutes maximum
- Overload inductance: 95% @ 110% load; 80% @ 150% load
- Impedance: 3%
- 10-year warranty

Agency Approvals:

- cUL_{US} listed (E197592)
- CE marked
- RoHS



LR2-10P2-1PH



LR-2100



LR2-40P2

Typical Line Reactors

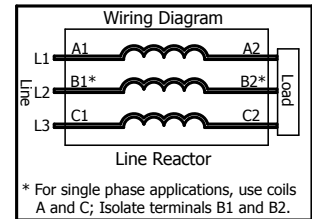

Wiring

* For single phase applications, use coils A and C; Isolate terminals B1 and B2.

LR(2) Series Line/Load Reactors – Compatibility with AutomationDirect AC Drives

For Reactor compatibility with CFW100 AC Drives, please refer to [“General Accessories for CFW100 Drives” on page tCFW-15.](#)

For Reactor compatibility with CFW300 AC Drives, please refer to [“General Accessories for CFW300 Drives” on page tCFW-8.](#)

For Reactor compatibility with GS1 AC Drives, please refer to [“GS1 Specifications” on page tGSX-2.](#)

For Reactor compatibility with GS2 AC Drives, please refer to [“GS2 Specifications” on page tGSX-9.](#)

For Reactor compatibility with GS3 AC Drives, please refer to [“GS3 External Accessories List” on page tGSX-25.](#)

For Reactor compatibility with GS4 AC Drives, please refer to [“GS4 Line Reactors and Output Filters” on page tGSX-50.](#)

Drives Accessories – Line/Load Reactors

LR(2) Series Line/Load Reactors for AC Drives – Specifications

Line/Load Reactors for AC Drives – LR(2) Series												
Part Number (0)	Price	Dimension Drawing	Max Rated Amps	Inductance [mH]	Watt Loss	System Voltage	Weight (lb [kg])	Wire Range	Terminal Torque (lb-in)	Operating Temperature	Storage Temperature	Environment
LR-10P2-1PH (2)(3)		1	5.8	1.58	8.0	120	2.6 [1.2]	18–12 AWG	10	-40 – 104 °F [-40 – 40 °C]	-40 – 149 °F [-40 – 65 °C]	NEMA: open IP00 no corrosive gases
LR2-10P2-1PH (2)		13	10	1.35	21		4	18–12 AWG	10			
LR-10P5-1PH (2)(3)		1	9.8	0.93	11.7		2.7 [1.2]	18–12 AWG	10			
LR2-10P5-1PH (2)		13	12	0.971	29		4	18–12 AWG	10			
LR-11P0-1PH (2)(3)		2	16	0.57	17.4		4.2 [1.9]	18–12 AWG	20			
LR2-11P0-1PH (1)(2)		14	17	1.03	53		8	18–4 AWG	20			
LR2-11P5-1PH (2)		15	34	0.342	64		12	18–4 AWG	20			
LR2-20P2-1PH (2)(4)		16	4.2	6.4	23.5	240	1.4	22–12 AWG	9	122°F [50°C] max	-40 – 149 °F [-40 – 65 °C]	NEMA: open IP00 no corrosive gases
LR2-20P2 (4)		16	3.4	7.4	26.4	240	1.4	22–12 AWG	9	122°F [50°C] max		
LR-20P5-1PH (2)(3)		1	4.9	3.74	11.2	240	2.8 [1.3]	18–12 AWG	10	104°F [40°C] max		
LR2-20P5-1PH (2)		17	7.6	3.56	39	240	3	22–12 AWG	9	122°F [50°C] max		
LR2-20P5 (4)		16	5	4.6	30.6	240	1.4	22–12 AWG	9	122°F [50°C] max		
LR2-20P7 (4)		17	8.2	2.9	49	240	3	22–12 AWG	9	122°F [50°C] max		
LR-21P0-1PH (2)		1	8	2.29	15.9	240	2.8 [1.3]	18–12 AWG	10	104°F [40°C] max		
LR2-21P0-1PH (1)(2)(4)		13	10	2.31	31	240	4	18–12 AWG	10	104°F [40°C] max		
LR-21P0 (3)		3	4.6	2.46	11	208/240	4.0 [1.8]	18–12 AWG	10	104°F [40°C] max		
LR2-21P0 (4)		17	11.6	2.0	64	240	3.2	22–12 AWG	9	122°F [50°C] max		
LR2-21P5-1PH (2)(4)		13	14	1.68	40	240	4	18–12 AWG	10	104°F [40°C] max		
LR2-21P5 (4)		17	11.6	2.0	64	240	3.2	22–12 AWG	9	122°F [50°C] max		
LR-22P0-1PH (2)		2	12	1.53	24.3	240	4.3 [2.0]	18–12 AWG	20	104°F [40°C] max		
LR2-22P0-1PH (1)(2)(4)		14	17	1.03	53	240	8	18–4 AWG	20	104°F [40°C] max		
LR-22P0 (3)		3	7.5	1.35	21	208/240	4.0 [1.8]	18–12 AWG	10	104°F [40°C] max		
LR2-22P0 (4)		17	11.6	2.0	64	240	3.2	22–12 AWG	9	122°F [50°C] max		
LR-23P0-1PH (2)		2	17	1.08	27.3	240	4.3 [2.0]	18–12 AWG	20	104°F [40°C] max		
LR-23P0		3	10.6	0.97	38	208/240	4.0 [1.8]	18–12 AWG	10	104°F [40°C] max		
LR-25P0		4	16.7	0.626	48	208/240	8.0 [3.6]	18–4 AWG	20	104°F [40°C] max		
LR-27P5		4	24.2	0.434	65	208/240	8.0 [3.6]	18–4 AWG	20	104°F [40°C] max		
LR-2010		5	30.8	0.342	96	208/240	12 [5.4]	18–4 AWG	20	104°F [40°C] max		
LR-2015		5	46.2	0.22	64	208/240	12 [5.4]	18–4 AWG	20	104°F [40°C] max		
LR-2020		5	59.4	0.172	85	208/240	12 [5.4]	18–4 AWG	20	104°F [40°C] max		
LR-2025		6	74.8	0.138	94	208/240	15 [6.8]	18–4 AWG	18–16 AWG: 25 14–6 AWG: 30 4 AWG: 35	104°F [40°C] max		
LR-2030		7	88	0.116	135	208/240	33 [15]	6AWG–2/0 (AL or CU)	120	104°F [40°C] max		
LR-2040		7	114	0.0886	149	208/240	33 [15]	6AWG–2/0 (AL or CU)	120	104°F [40°C] max		
LR-2050		8	143	0.0699	154	208/240	36 [16]	6AWG–250kcmil (AL or CU)	275	104°F [40°C] max		
LR-2060		18	180	0.0624	209	208/240	46	6AWG–250MCM	275	104°F [40°C] max		
LR-2075		19	211	0.0487	294	208/240	52	4AWG–600MCM	500	104°F [40°C] max		
LR-2100		19	280	0.0364	276	208/240	52	4AWG–600MCM	500	104°F [40°C] max		

0) Impedance = 3% for all reactors, except as otherwise noted.

1) Impedance = 5% for reactors marked with this note, but they function as 3% reactors in the ADC drive application.

2) Single-phase line reactors are for use only with single-phase drive inputs. Single-phase line reactors should NOT be installed on the output side of AC drives.

3) This reactor is recommended for existing installations only; product will be discontinued after existing stock is depleted.

4) Optional mounting accessories are available for these models. See “Line/Load Reactors – Mounting Accessories” section for details.

5) LR-4250 & LR-4300 have dual-connector lugs, and will require multiple conductors per phase of the appropriate size to fit the lugs.

(table continued next page)

Drives Accessories – Line/Load Reactors

LR(2) Series Line/Load Reactors for AC Drives – Specifications

Line/Load Reactors for AC Drives – LR(2) Series (continued from previous page)												
Part Number (1)	Price	Dimension Drawing	Max Rated Amps	Inductance [mH]	Watt Loss	System Voltage	Weight (lb [kg])	Wire Range	Terminal Torque [lb·in]	Operating Temperature	Storage Temperature	Environment
LR2-40P2 (4)		16	1.4	31.5	5	480	1.3	22–12 AWG	9	122°F [50°C] max	-40 – 149 °F [-40 – 65 °C]	NEMA: open IP00 no corrosive gases
LR2-40P3 (4)		16	1.7	27.6	6.2		1.3	22–12 AWG	9	122°F [50°C] max		
LR2-40P5 (4)		16	1.6	20	9.7		1.3	22–12 AWG	9	122°F [50°C] max		
LR2-40P7 (4)		16	2.3	13.8	12.1		1.3	22–12 AWG	9	122°F [50°C] max		
LR2-41P0 (4)		16	2.3	10.5	25.2		1.2	22–12 AWG	9	122°F [50°C] max		
LR2-41P5 (4)		16	3.4	7.4	26.4		1.4	22–12 AWG	9	122°F [50°C] max		
LR-42P0 (3)		3	3.4	5.79	19		4.0 [1.8]	18–12 AWG	10	104°F [40°C] max		
LR2-42P0 (4)		16	4.2	6.5	23.5		1.4	22–12 AWG	9	122°F [50°C] max		
LR-43P0 (3)		3	4.8	4.27	23		4.0 [1.8]	18–12 AWG	10	104°F [40°C] max		
LR2-43P0 (4)		16	5	4.6	30.6		1.4	22–12 AWG	9	122°F [50°C] max		
LR2-44P0 (4)		17	7.6	3.56	39		3	22–12 AWG	9	122°F [50°C] max		
LR-45P0 (3)		3	7.6	2.77	49		4.0 [1.8]	18–12 AWG	10	104°F [40°C] max		
LR2-45P0 (4)		17	8.2	2.9	49		3	22–12 AWG	9	122°F [50°C] max		
LR-47P5 (3)		3	11	1.68	40		4.0 [1.8]	18–12 AWG	10	104°F [40°C] max		
LR2-47P5 (4)		17	11.6	2	64		3.2	22–12 AWG	9	122°F [50°C] max		
LR-4010		3	14	1.29	64		4.0 [1.8]	18–12 AWG	10	104°F [40°C] max		
LR-4015		4	21	0.912	65		8.0 [3.6]	18–4 AWG	20	104°F [40°C] max		
LR-4020		4	27	0.694	79		8.0 [3.6]	18–4 AWG	20	104°F [40°C] max		
LR-4025		5	34	0.569	96		10 [4.5]	18–4 AWG	20	104°F [40°C] max		
LR-4030		5	40	0.469	105		10 [4.5]	18–4 AWG	20	104°F [40°C] max		
LR-4040		6	52	0.387	114		15 [6.8]	18–4 AWG	20	104°F [40°C] max		
LR-4050		9	65	0.295	114		25 [11]	#22–4 AWG	22–16 AWG: 25 14–6 AWG: 30 4 AWG: 35	104°F [40°C] max		
LR-4060		9	77	0.227	169		33 [15]	2/0 – 6AWG (AL or CU)	120	104°F [40°C] max		
LR-4075		7	96	0.196	193		46 [21]	250kcmil – 6AWG (AL or CU)	275	104°F [40°C] max		
LR-4100		10	124	0.152	225		74 [34]	(1) 4 AWG – 600kcmil (2) 1/0 – 250kcmil	500	104°F [40°C] max		
LR-4125		10	156	0.117	254		74 [34]	(2)** 4 AWG – 350kcmil (AL or CU)	275	104°F [40°C] max		
LR-4150		10	180	0.103	299		4.0 [1.8]	18–12 AWG	10	104°F [40°C] max		
LR-4200		11	240	0.0839	280		1.3	22–12 AWG	9	122°F [50°C] max		
LR-4250 (5)		12	302	0.0654	337		1.4	22–12 AWG	9	122°F [50°C] max		
LR-4300 (5)		12	361	0.0565	381		1.5	22–12 AWG	9	122°F [50°C] max		
LR-51P0 (3)		3	1.7	15.9	12	4.0 [1.8]	18–12 AWG	10	104°F [40°C] max			
LR2-51P0 (4)		16	2.1	16.2	16.2	4.0 [1.8]	18–12 AWG	10	104°F [40°C] max			
LR2-51P5 (4)		16	3.4	11.5	17.2	4.0 [1.8]	18–12 AWG	10	104°F [40°C] max			
LR-52P0 (3)		3	2.7	9.29	22	4.0 [1.8]	18–12 AWG	10	104°F [40°C] max			
LR2-52P0 (4)		16	3.2	10.2	20.5	4.0 [1.8]	18–12 AWG	10	104°F [40°C] max			
LR-53P0 (3)		3	3.9	6.74	23.3	3.5	22–12 AWG	9	122°F [50°C] max			
LR2-53P0 (4)		17	4.8	7.07	30	2.9	22–12 AWG	9	122°F [50°C] max			
LR2-54P0 (4)		17	7.6	5.63	30	4.0 [1.8]	18–12 AWG	10	104°F [40°C] max			
LR-55P0 (3)		3	6.1	4.51	34.7	3	22–12 AWG	9	122°F [50°C] max			
LR2-55P0 (4)		17	7.6	4.52	44	3.2	22–12 AWG	9	122°F [50°C] max			
LR2-57P5 (4)		17	9.6	3.1	57	4.0 [1.8]	18–12 AWG	10	104°F [40°C] max			
LR-5010		3	11	2.47	43.8	4.0 [1.8]	18–12 AWG	10	104°F [40°C] max			

1) Impedance = 3% for all reactors.

2) Single-phase line reactors are for use only with single-phase drive inputs. Single-phase line reactors should NOT be installed on the output side of AC drives.

3) This reactor is recommended for existing installations only; product will be discontinued after existing stock is depleted.

4) Optional mounting accessories are available for these models. See “Line/Load Reactors – Mounting Accessories” section for details.

5) LR-4250 & LR-4300 have dual-connector lugs, and will require multiple conductors per phase of the appropriate size to fit the lugs.

Drives Accessories – Line/Load Reactor Mounting Accessories

LR(2) Series Line/Load Reactors – Mounting Accessories

LR(2) series reactors have differing mounting options depending on the model. The models listed below have an integral two-bolt mounting method, and also offer optional mounting adapters that allow other mounting methods.

Adapter Plate Kits [LR2-AP1](#) and [LR2-AP2](#) allow for universal panel mounting with these models.

DIN Rail Mounting Kits [LR2-DR1](#) and [LR2-DR2](#) allow DIN rail mounting with these models.

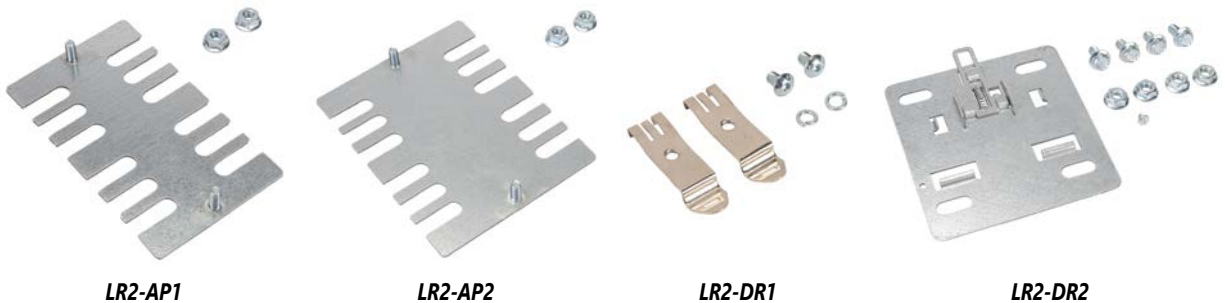

LR2 Series Line Reactor Mounting Adapters			
Part Number	Price	Description	Dimension Drawing
LR2-AP1		Adapter Plate Kit; includes 2 flange nuts (10-32); Dimensions 4.45" x 2.63"	16a
LR2-AP2		Adapter Plate Kit; includes 2 flange nuts (10-32); Dimensions 4.45" x 3.51"	16b
LR2-DR1		DIN Rail Mounting Clips and Hardware Kit; includes 2 screws (M5-0.8 x 8mm), 2 washers, 2 clips	16c
LR2-DR2		DIN Rail Mounting Plate and Hardware Kit; includes 4 bolts (0.25-20 x 0.50) and 4 flange nuts	17a

LR2 Line Reactor Mounting Adapter Selection Table				
ADC Line Reactor Part #	Adapter Plate Kits Part #		DIN Rail Mount Kits Part #	
	LR2-AP1	LR2-AP2	LR2-DR1	LR2-DR2
LR2-20P2-1PH	√	√	√	–
LR2-20P2	√	√	√	–
LR2-20P5-1PH	–	–	–	√
LR2-20P5	√	√	√	–
LR2-20P7	–	–	–	√
LR2-21P0	–	–	–	√
LR2-21P5	–	–	–	√
LR2-22P0	–	–	–	√
LR2-40P2	√	√	√	–
LR2-40P3	√	√	√	–
LR2-40P5	√	√	√	–
LR2-40P7	√	√	√	–
LR2-41P0	√	√	√	–
LR2-41P5	√	√	√	–
LR2-42P0	√	√	√	–
LR2-43P0	√	√	√	–
LR2-44P0	–	–	–	√
LR2-45P0	–	–	–	√
LR2-47P5	–	–	–	√
LR2-51P0	√	√	√	–
LR2-51P5	√	√	√	–
LR2-52P0	√	√	√	–
LR2-53P0	–	–	–	√
LR2-54P0	–	–	–	√
LR2-55P0	–	–	–	√
LR2-57P5	–	–	–	√

Drives Accessories – Line/Load Reactors

LR(2) Series Line/Load Reactors – Dimensions

(UNITS = IN [MM])

SEE OUR WEBSITE: _____ FOR COMPLETE ENGINEERING DRAWINGS.

1) LR(2) LINE REACTORS DIMENSION DRAWING #1

LR-10P2-1PH, LR-10P5-1PH, LR-20P5-1PH, LR-21P0-1PH

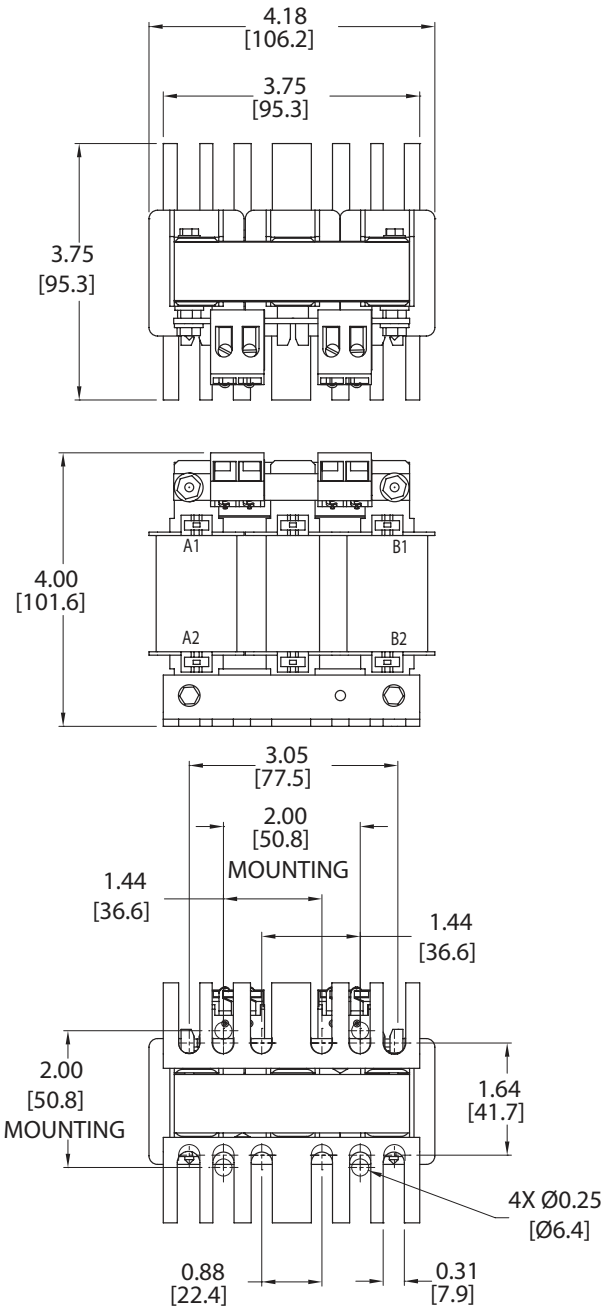

2) LR(2) LINE REACTORS DIMENSION DRAWING #2

LR-11P0-1PH, LR-22P0-1PH, LR-23P0-1PH

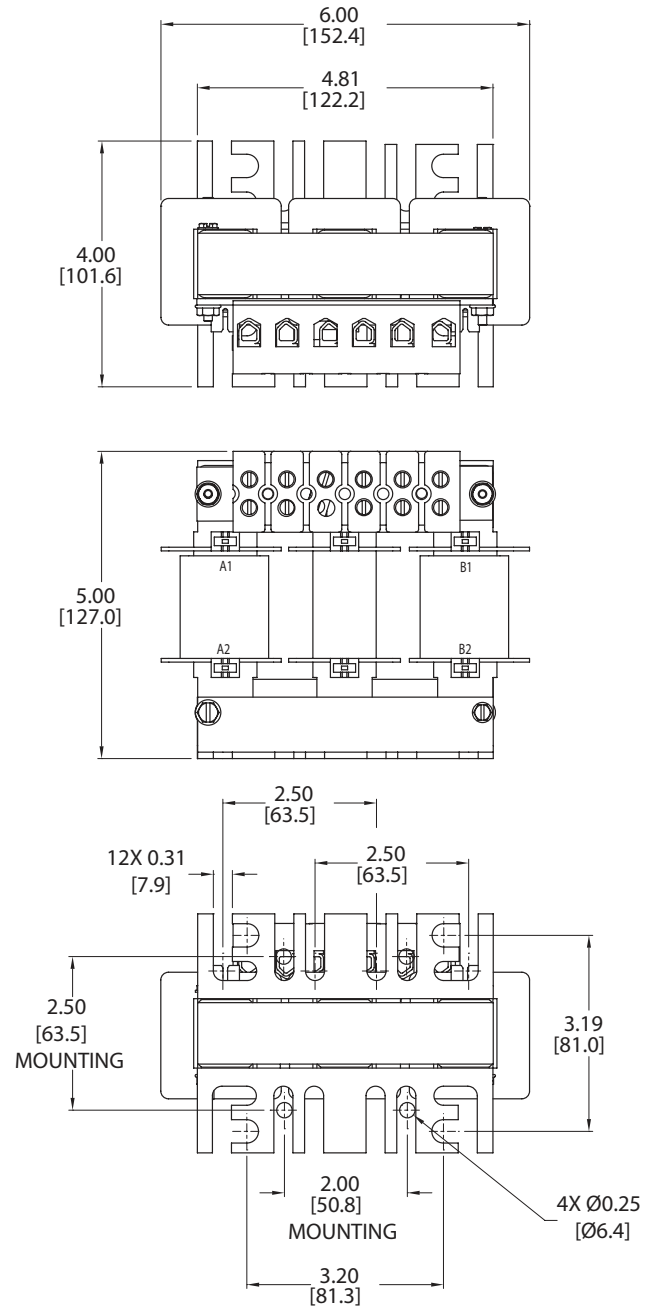

Drives Accessories – Line/Load Reactors

LR(2) Series Line/Load Reactors – Dimensions

(UNITS = IN [MM])

SEE OUR WEBSITE: _____ FOR COMPLETE ENGINEERING DRAWINGS.

3) LR(2) LINE REACTORS DIMENSION DRAWING #3

LR-21P0, LR-22P0, LR-23P0, LR-4010, LR-42P0, LR-43P0, LR-45P0, LR-47P5, LR-5010, LR-51P0, LR-52P0, LR-53P0, LR-55P0

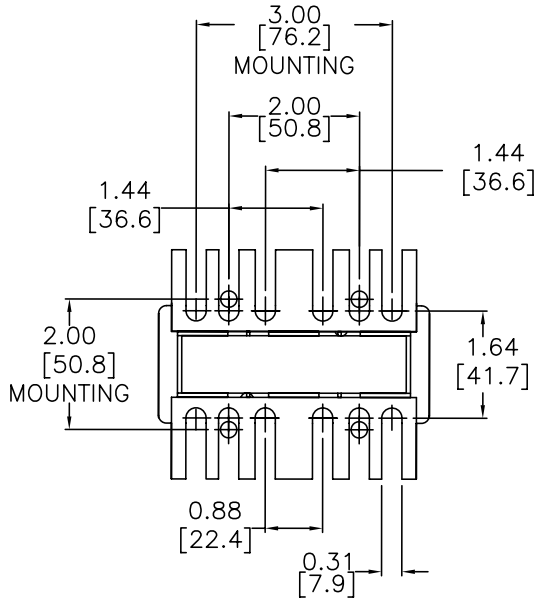
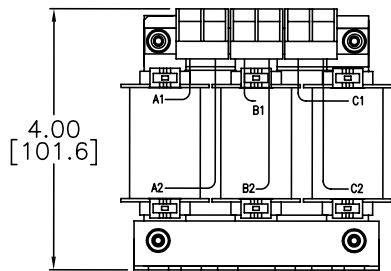
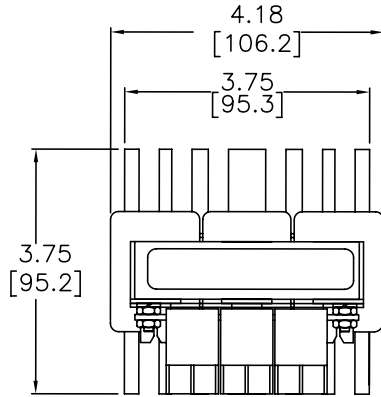

4) LR(2) LINE REACTORS DIMENSION DRAWING #4

LR-25P0, LR-27P5, LR-4015, LR-4020

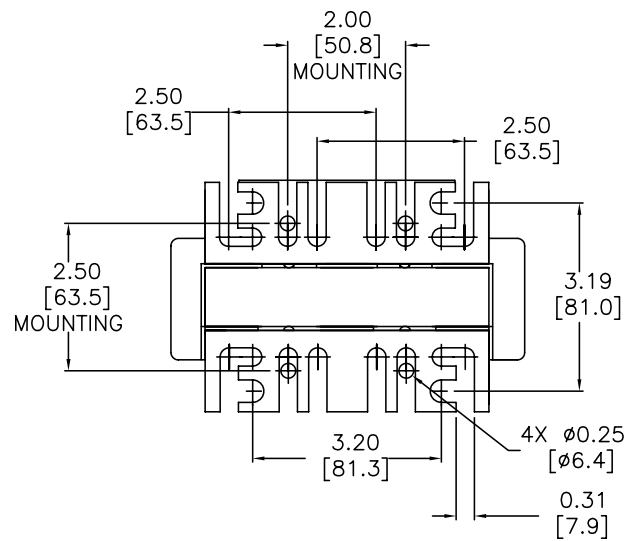
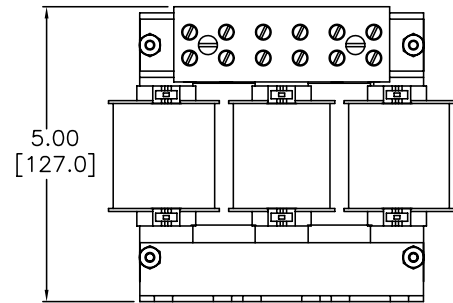
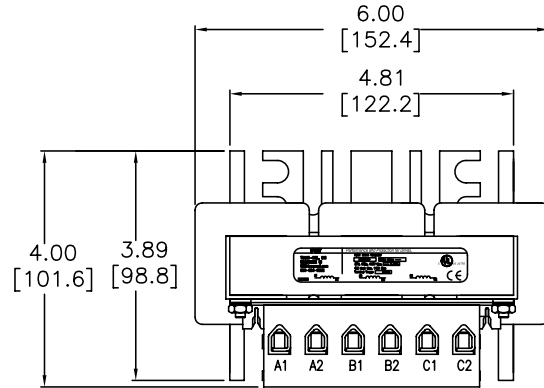

Drives Accessories – Line/Load Reactors

LR(2) Series Line/Load Reactors – Dimensions

(UNITS = IN [MM])

SEE OUR WEBSITE: _____ FOR COMPLETE ENGINEERING DRAWINGS.

7) LR(2) LINE REACTORS DIMENSION DRAWING #7
LR-2030, LR-2040, LR-4075

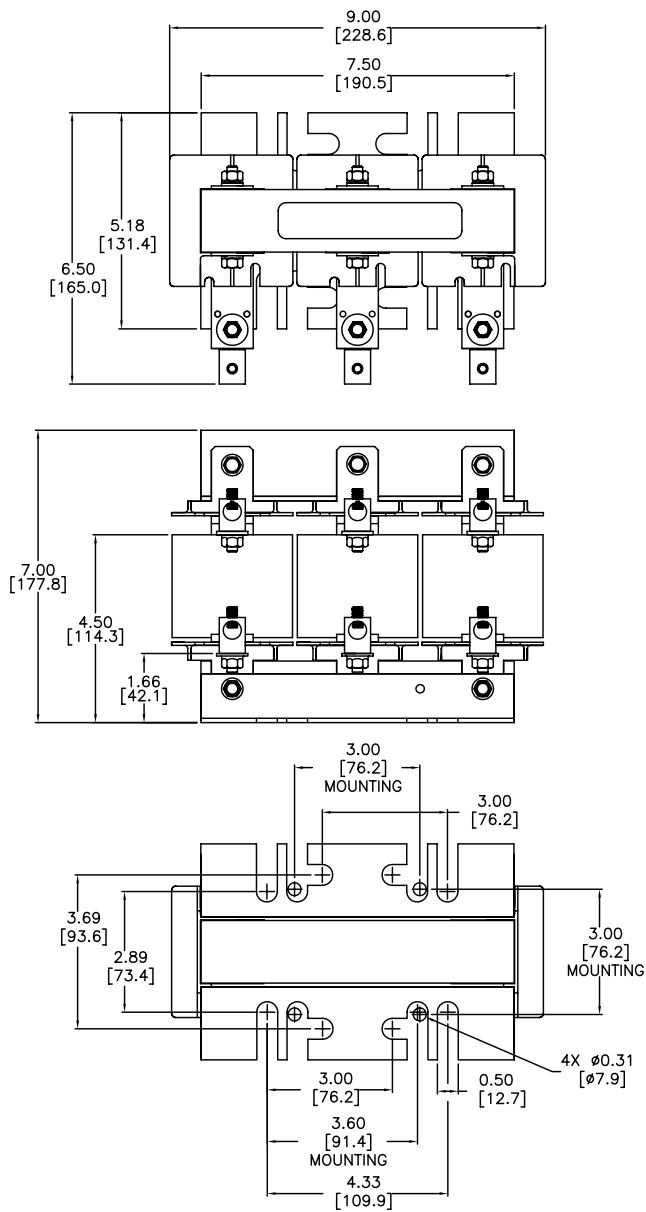

8) LR(2) LINE REACTORS DIMENSION DRAWING #8
LR-2050

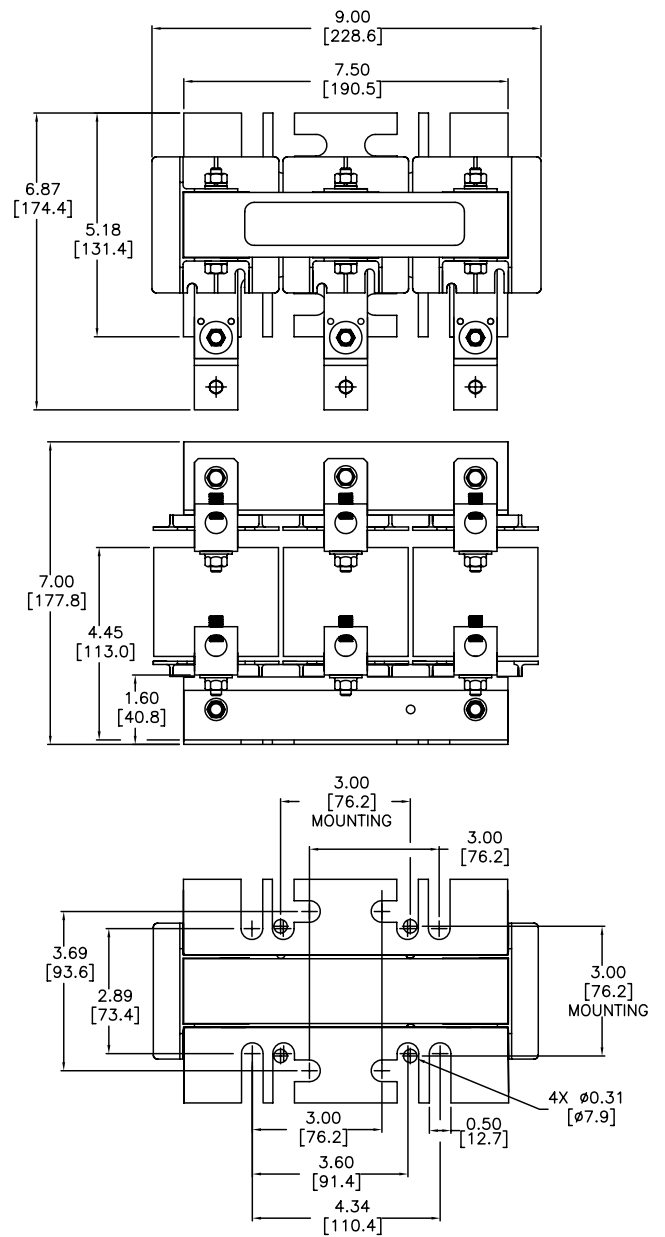

Drives Accessories – Line/Load Reactors

LR(2) Series Line/Load Reactors – Dimensions

(UNITS = IN [MM])

SEE OUR WEBSITE: _____ FOR COMPLETE ENGINEERING DRAWINGS.

9) LR(2) LINE REACTORS DIMENSION DRAWING #9
LR-4050, LR-4060

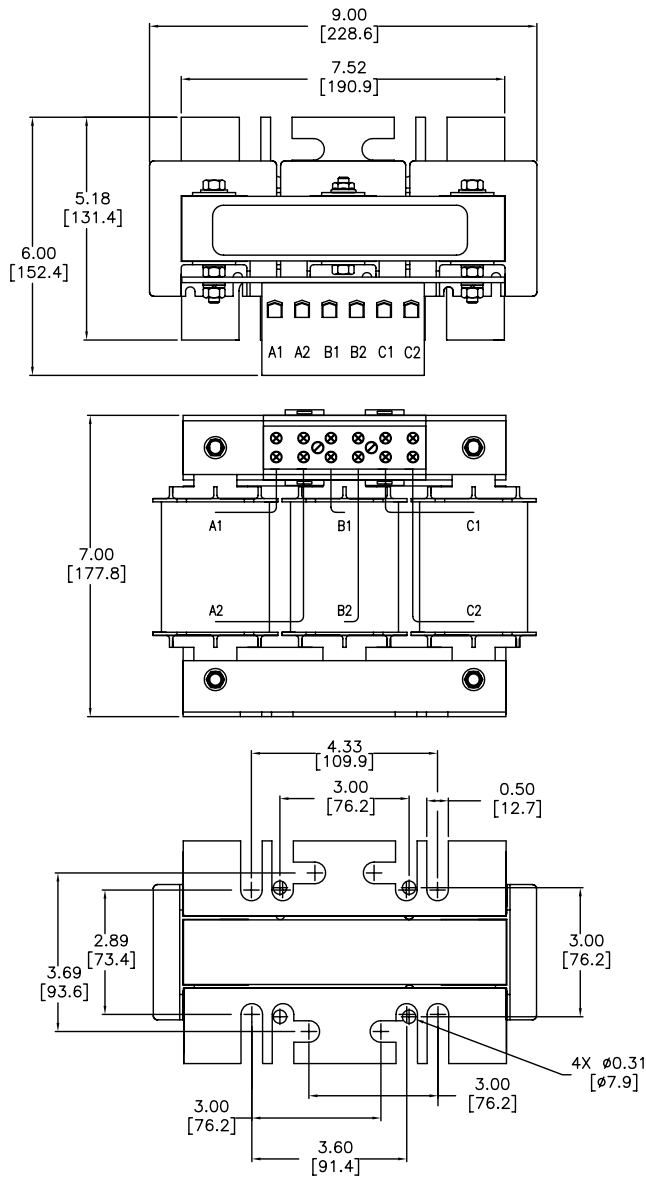

10) LR(2) LINE REACTORS DIMENSION DRAWING #10
LR-4100, LR-4125, LR-4150

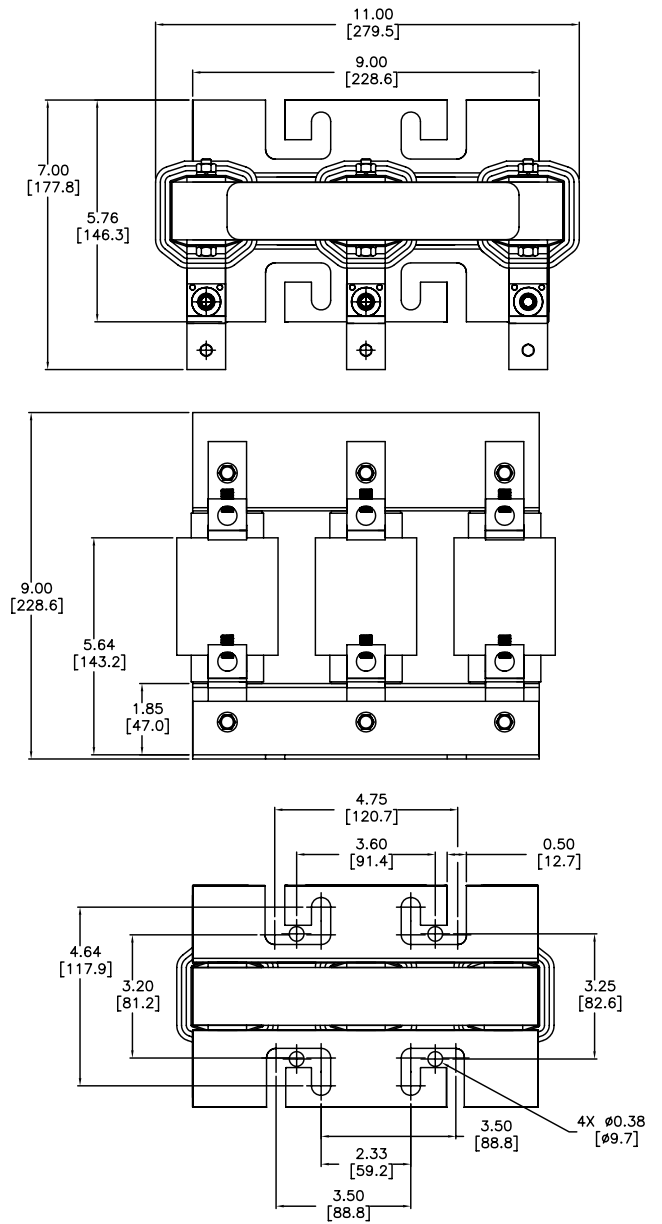

Drives Accessories – Line/Load Reactors

LR(2) Series Line/Load Reactors – Dimensions

(UNITS = IN [MM])

SEE OUR WEBSITE: _____ FOR COMPLETE ENGINEERING DRAWINGS.

11) LR(2) LINE REACTORS DIMENSION DRAWING #11
LR-4200

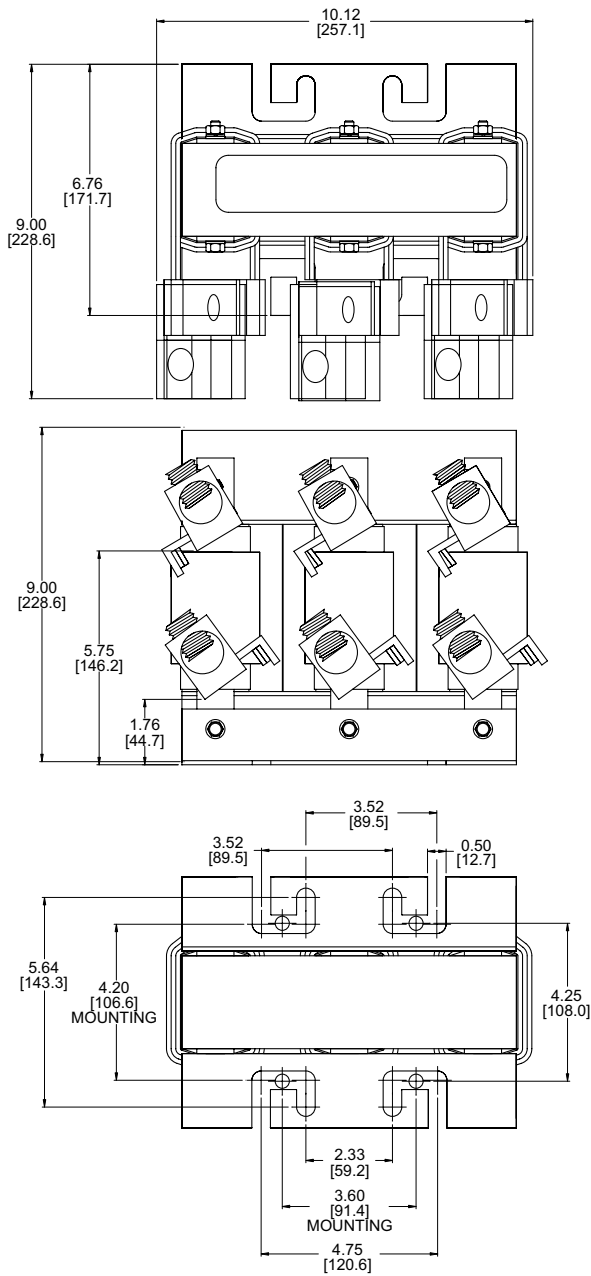

12) LR(2) LINE REACTORS DIMENSION DRAWING #12
LR-4250, LR-4300

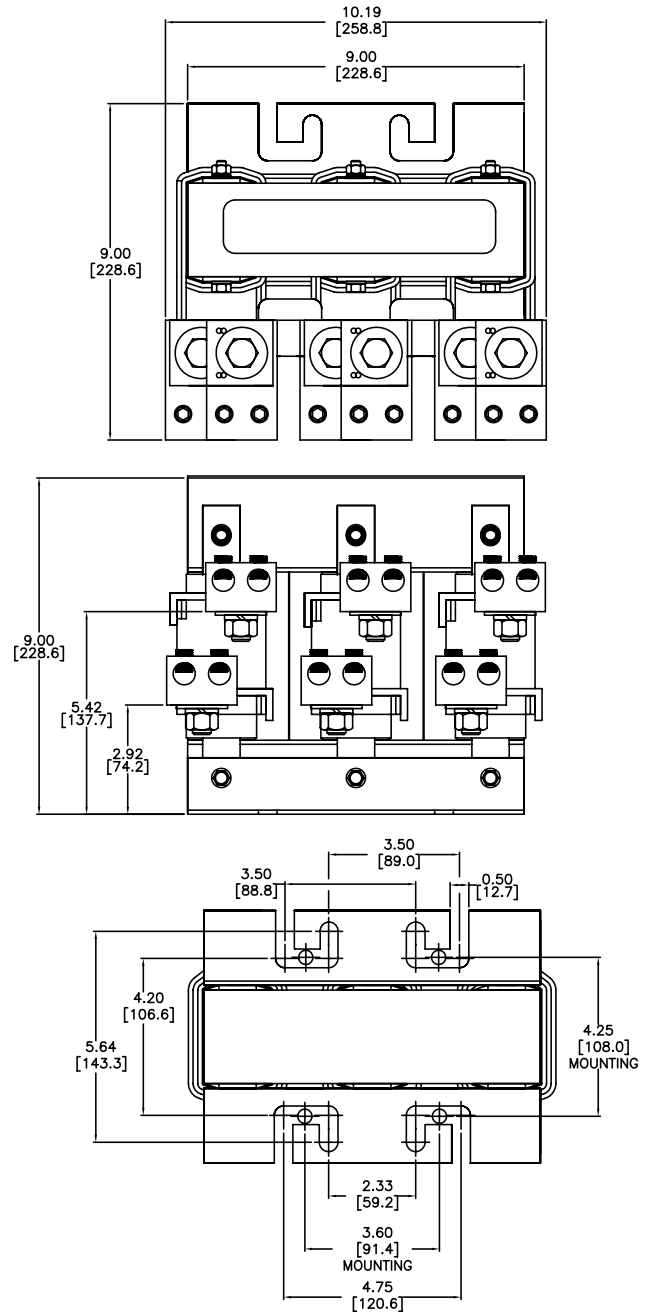

Drives Accessories – Line/Load Reactors

LR(2) Series Line/Load Reactors – Dimensions

(UNITS = IN [MM])

SEE OUR WEBSITE: _____ FOR COMPLETE ENGINEERING DRAWINGS.

13) LR(2) LINE REACTORS DIMENSION DRAWING #13

LR2-10P2-1PH, LR2-10P5-1PH, LR2-21P0-1PH, LR2-21P5-1PH

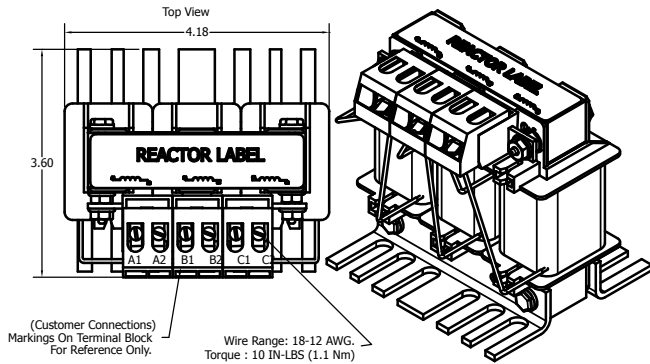

14) LR(2) LINE REACTORS DIMENSION DRAWING #14

LR2-11P0-1PH, LR2-22P0-1PH

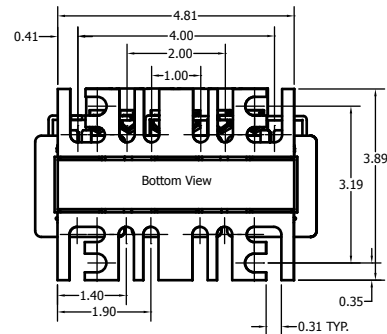
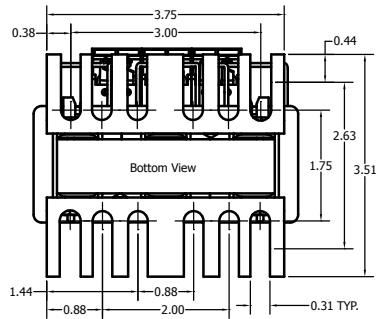
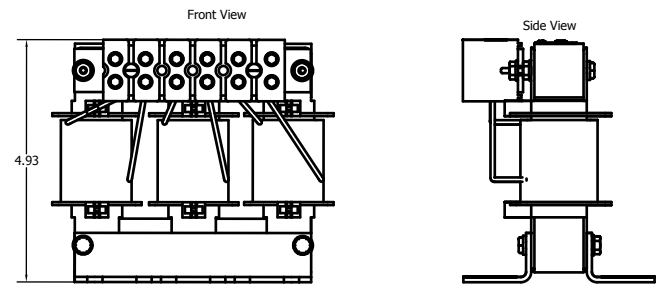
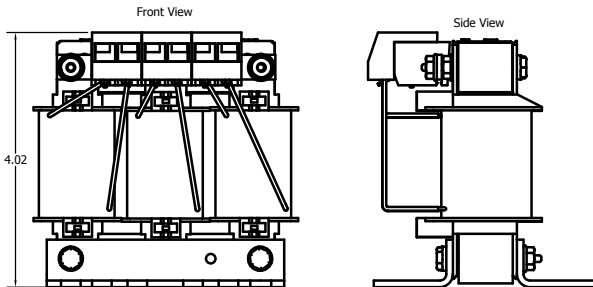
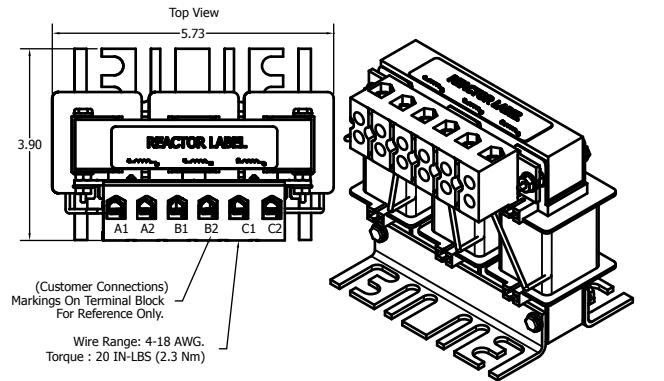

Drives Accessories – Line/Load Reactors

LR(2) Series Line/Load Reactors – Dimensions

(UNITS = IN [MM])

SEE OUR WEBSITE: _____ FOR COMPLETE ENGINEERING DRAWINGS.

15) LR(2) LINE REACTORS DIMENSION DRAWING #15 LR2-11P5-1PH

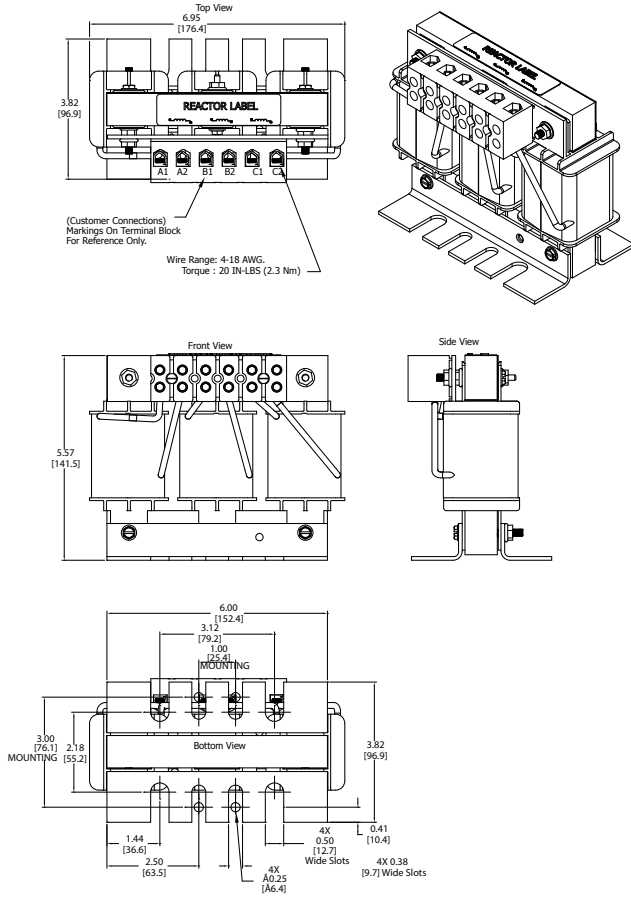

16) LR(2) LINE REACTORS DIMENSION DRAWING #16 LR2-20P2-1PH, LR2-20P2, LR2-20P5, LR2-40P2, LR2-40P3, LR2-40P5, LR2-40P7, LR2-41P0, LR2-41P5, LR2-42P0, LR2-43P0, LR2-51P0, LR2-51P5, LR2-52P0

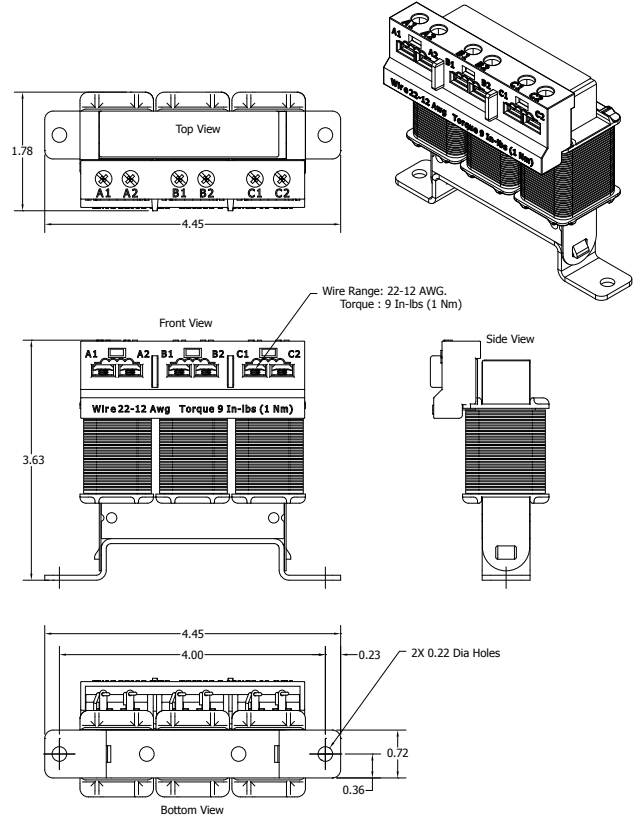

Drives Accessories – Line/Load Reactors

LR(2) Series Line/Load Reactors – Dimensions

(UNITS = IN [MM])

SEE OUR WEBSITE:

FOR COMPLETE ENGINEERING DRAWINGS.

16A) LR(2) LINE REACTORS DIMENSION DRAWING #16A

LR2-AP1 ADAPTER PLATE FOR UNIVERSAL MOUNTING FOR:

LR2-20P2-1PH, LR2-20P2, LR2-20P5, LR2-40P2, LR2-40P3, LR2-40P5, LR2-40P7, LR2-41P0, LR2-41P5, LR2-42P0, LR2-43P0, LR2-51P0, LR2-51P5, LR2-52P0

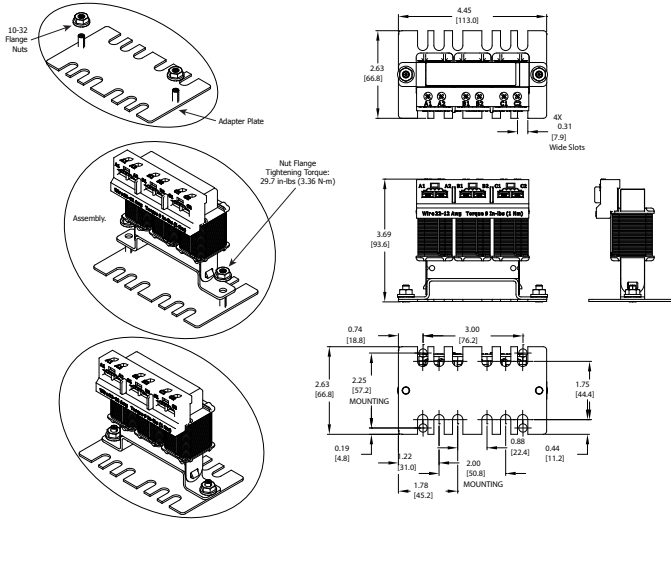

16B) LR(2) LINE REACTORS DIMENSION DRAWING # 16B

LR2-AP2 ADAPTER PLATE FOR UNIVERSAL MOUNTING FOR:

LR2-20P2-1PH, LR2-20P2, LR2-20P5, LR2-40P2, LR2-40P3, LR2-40P5, LR2-40P7, LR2-41P0, LR2-41P5, LR2-42P0, LR2-43P0, LR2-51P0, LR2-51P5, LR2-52P0

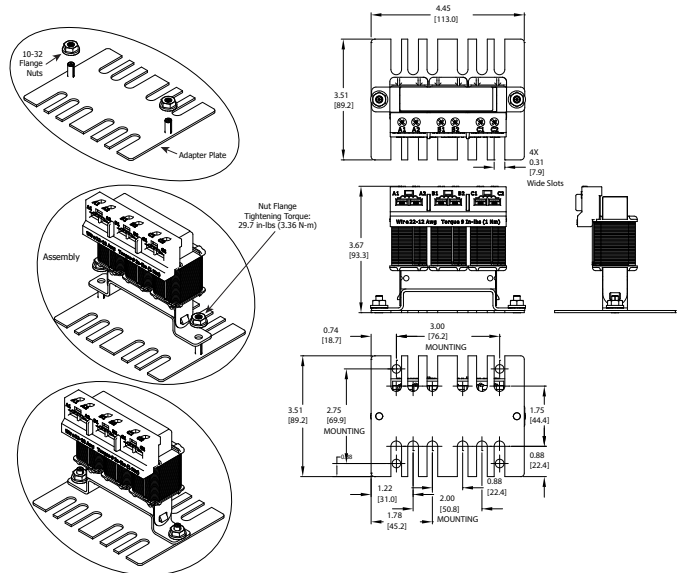

16C) LR(2) LINE REACTORS DIMENSION DRAWING #16C

LR2-DR1 HARDWARE KIT FOR DIN RAIL MOUNTING FOR:

LR2-20P2-1PH, LR2-20P2, LR2-20P5, LR2-40P2, LR2-40P3, LR2-40P5, LR2-40P7, LR2-41P0, LR2-41P5, LR2-42P0, LR2-43P0, LR2-51P0, LR2-51P5, LR2-52P0

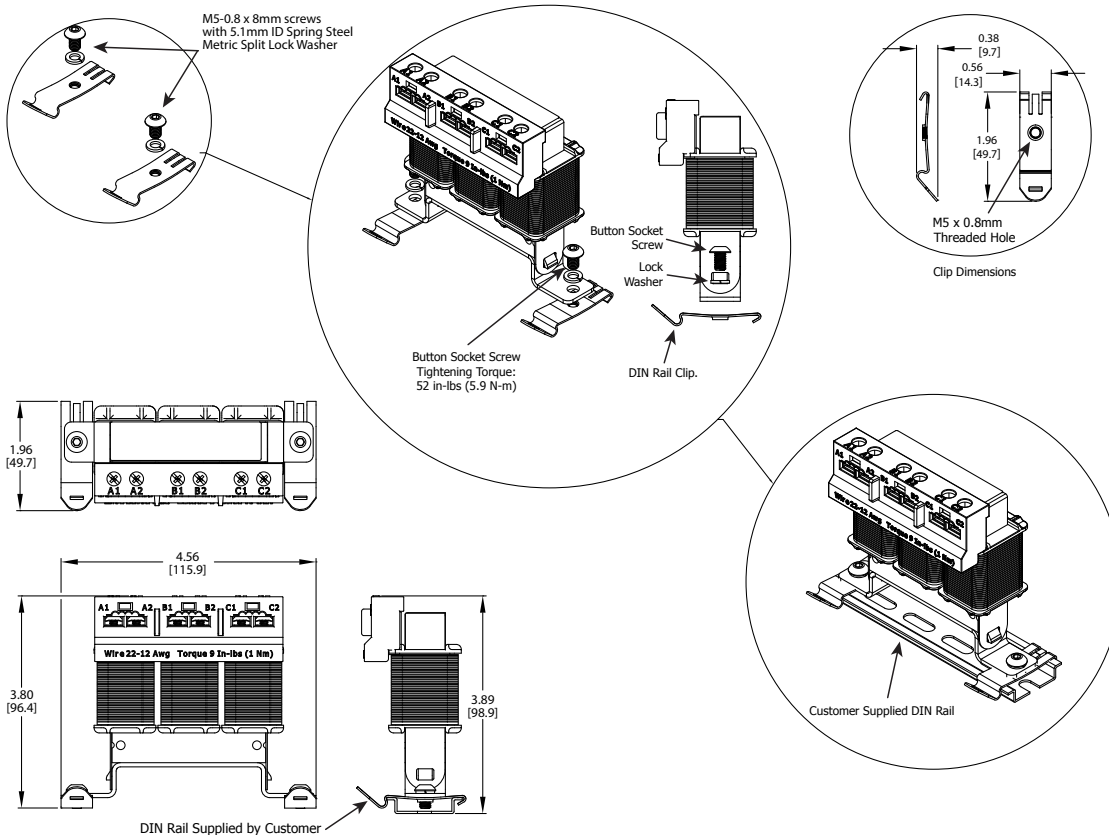

Drives Accessories – Line/Load Reactors

LR(2) Series Line/Load Reactors – Dimensions

(UNITS = IN [MM])

SEE OUR WEBSITE: _____ FOR COMPLETE ENGINEERING DRAWINGS.

17) LR(2) LINE REACTORS DIMENSION DRAWING #17

LR2-20P5-1PH, LR2-20P7, LR2-21P0, LR2-21P5, LR2-22P0, LR2-44P0, LR2-45P0, LR2-47P5, LR2-53P0, LR2-54P0, LR2-55P0, LR2-57P5

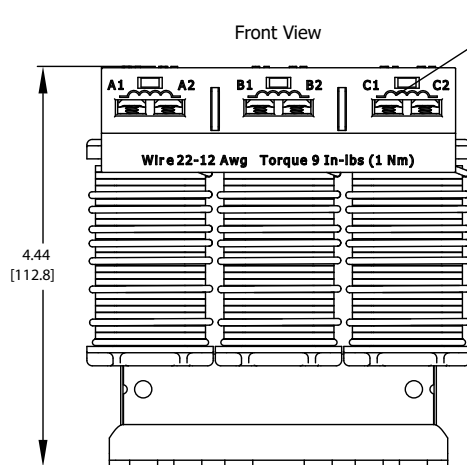
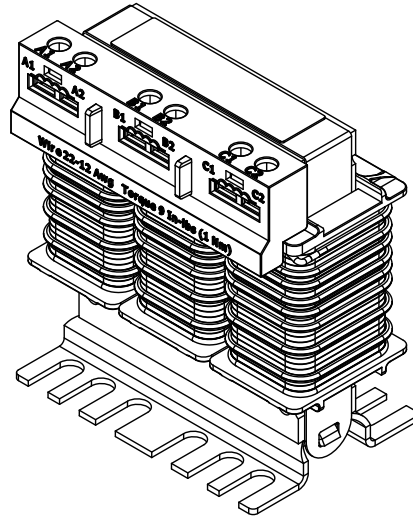
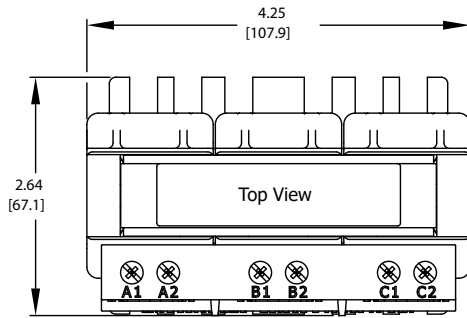

Wire Range: 22-12 AWG.
Torque : 9 In-lbs (1 Nm)

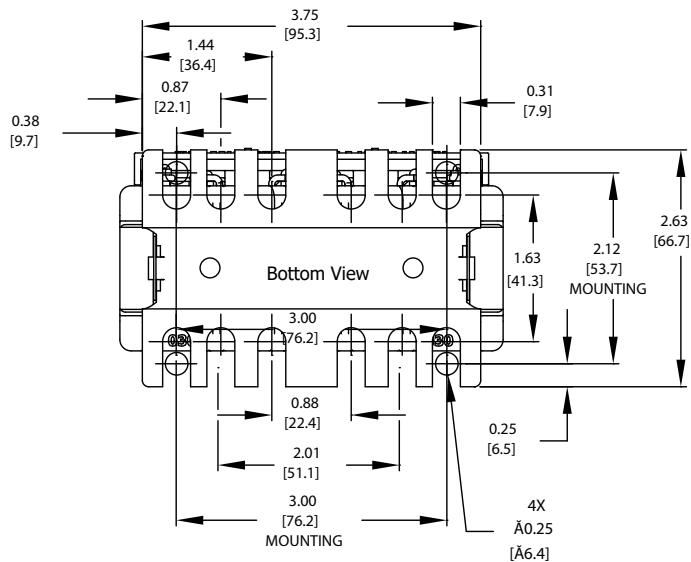
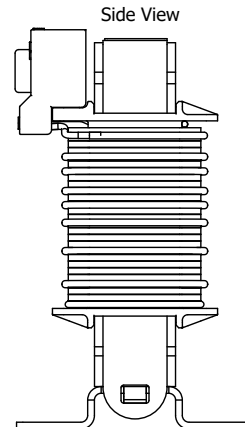

Drives Accessories – Line/Load Reactors

LR(2) Series Line/Load Reactors – Dimensions

(UNITS = IN [MM])

SEE OUR WEBSITE: _____ FOR COMPLETE ENGINEERING DRAWINGS.

17A) LR(2) LINE REACTORS DIMENSION DRAWING #17A

LR2-DR2 HARDWARE KIT FOR DIN RAIL MOUNTING FOR:

LR2-20P5-1PH, LR2-20P7, LR2-21P0, LR2-21P5, LR2-22P0, LR2-44P0, LR2-45P0, LR2-47P5, LR2-53P0, LR2-54P0, LR2-55P0, LR2-57P5

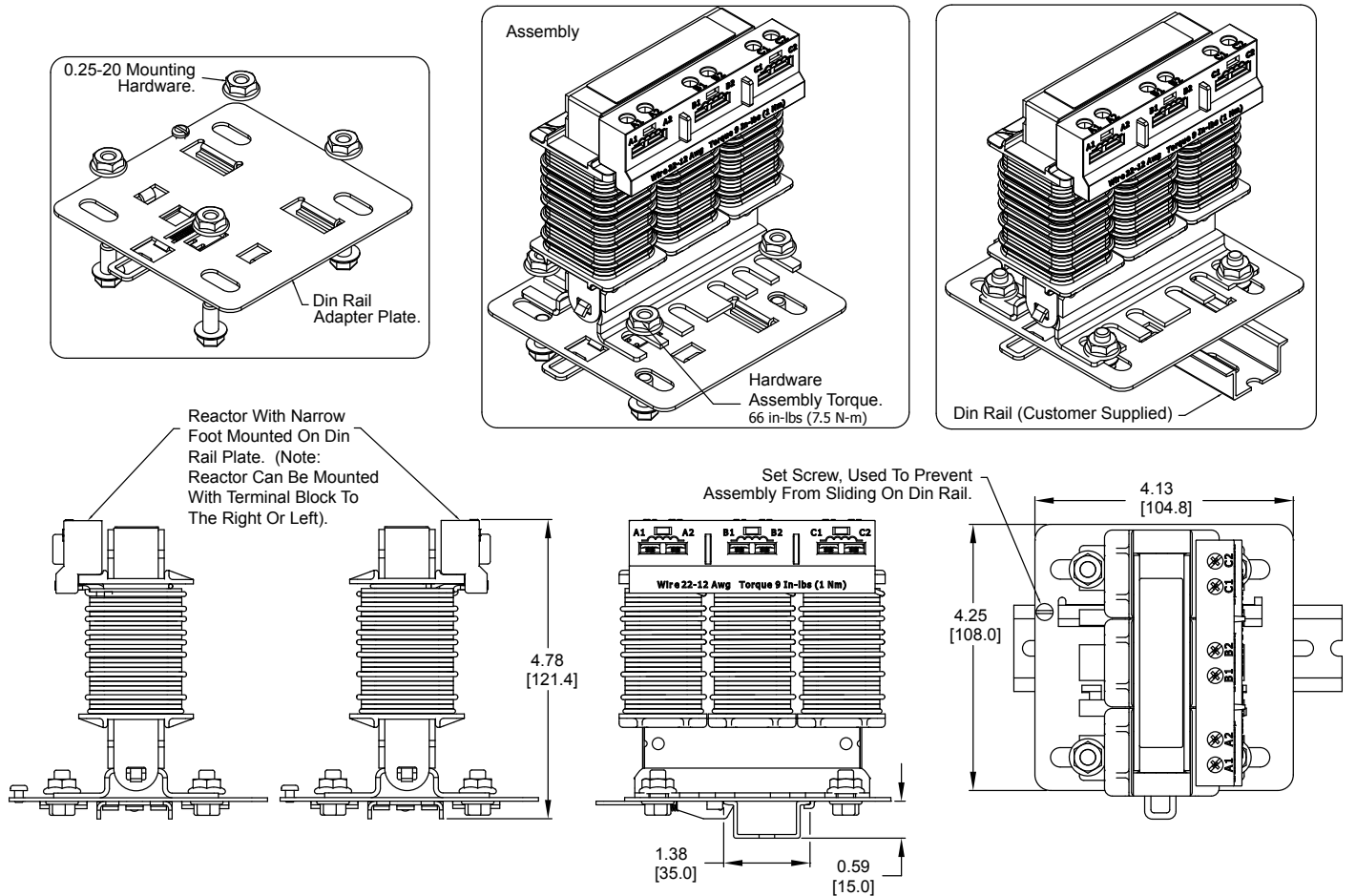

Drives Accessories – Line/Load Reactors

LR(2) Series Line/Load Reactors – Dimensions

(UNITS = IN [MM])

SEE OUR WEBSITE: _____ FOR COMPLETE ENGINEERING DRAWINGS.

18) LR(2) LINE REACTORS DIMENSION DRAWING #18 LR-2060

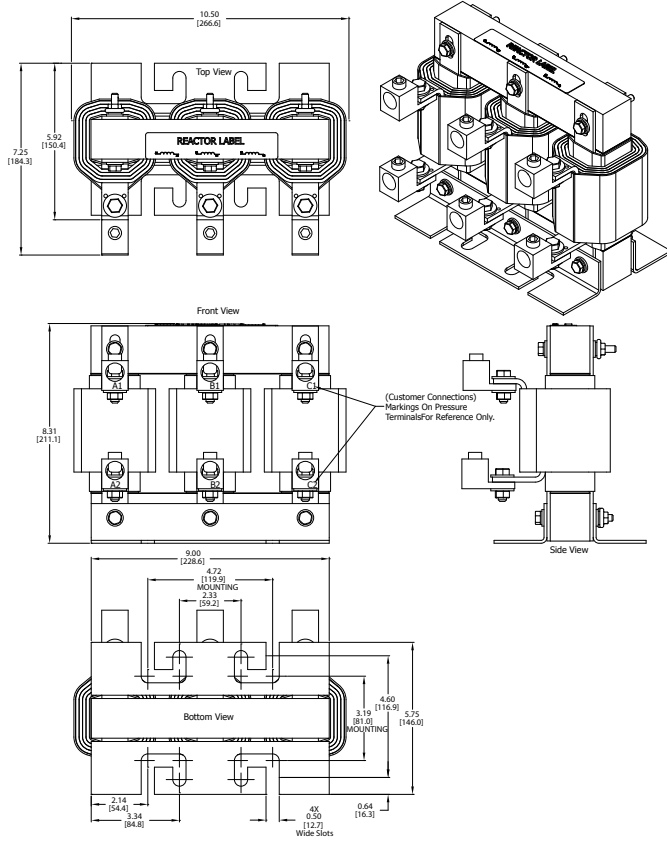

19) LR(2) LINE REACTORS DIMENSION DRAWING #19 LR2075, LR2100

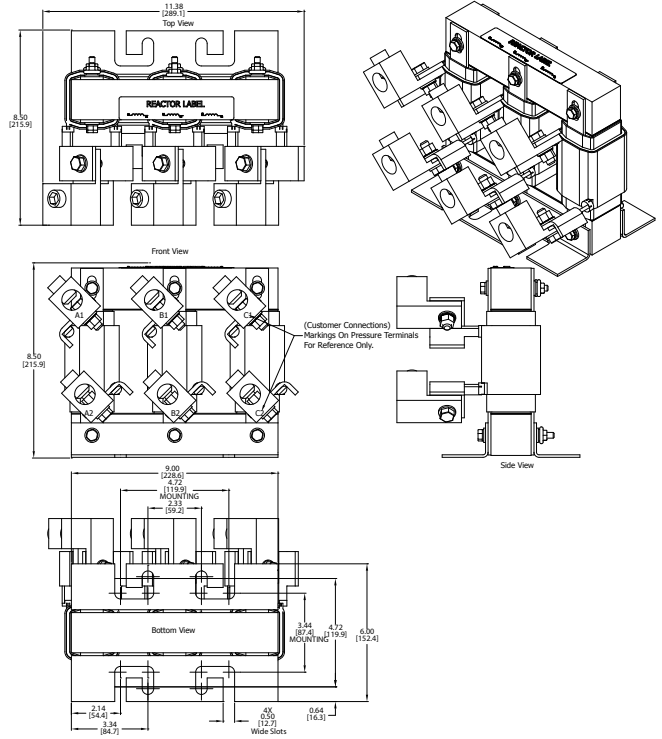

GS/DURAPULSE Drives Accessories – Line/Load Reactors

Line/Load Reactors for GS/DURAPULSE AC Drives – Generic One-Line Wiring Examples



WARNING: CONSULT THE APPLICABLE GS DRIVE USER MANUAL BEFORE ACTUALLY WIRING THE DRIVE!

Input side of the drive

When installed on the input side of the AC drive, line reactors will reduce line notching, and limit current and voltage spikes and surges from the incoming line. The line reactor will also reduce harmonic distortion from the drive onto the line. Units are installed in front of the AC drive as shown.

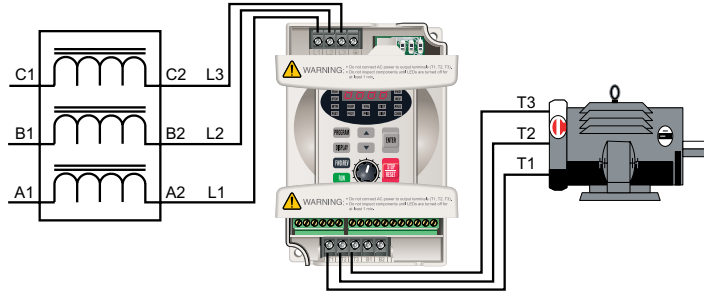

Note: Single phase line reactors should NOT be installed on the output of the AC drive. Use only three-phase reactors on drive outputs, and only for three-phase motors.

Output side of the drive

When installed on the output side of the drive, line reactors protect the drive from short circuits at the load. Voltage and current waveforms from the drive are enhanced, reducing motor overheating and noise emissions.

Note: If installing a line reactor on the output side of the drive, especially with motor lead lengths in excess of 75 feet, lower the drive PWM output carrier frequency to 4kHz in order to protect the line reactor from excess heating and possible damage.

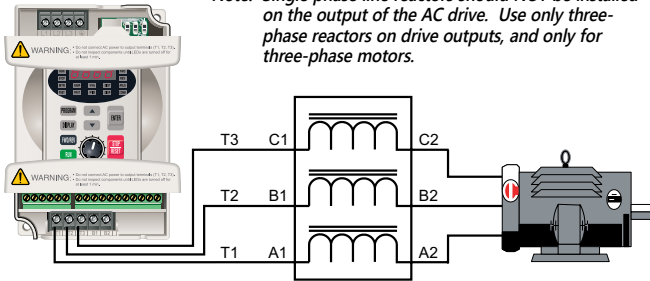

Multiple drives

Individual line reactors are recommended when installing multiple drives on the same power line. Individual line reactors eliminate crosstalk between multiple drives and provide isolated protection for each drive for its own specific load.

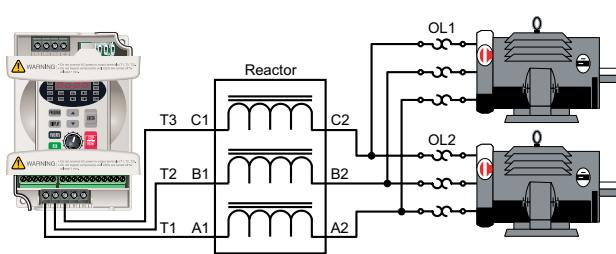
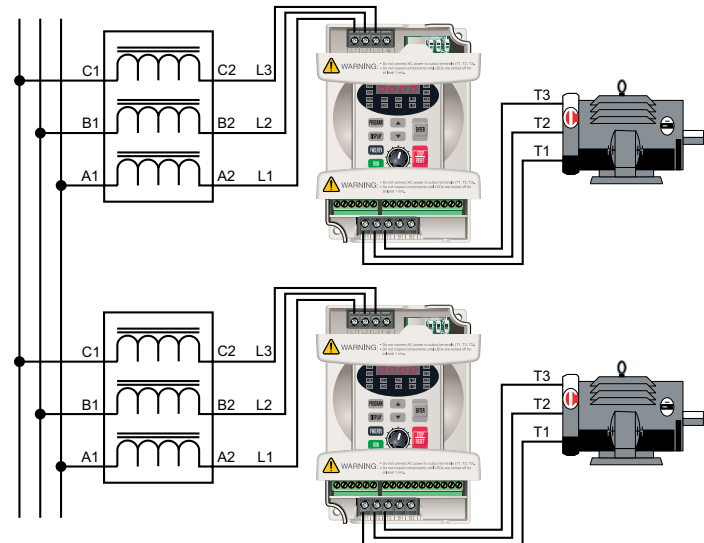

Multiple motors

A single reactor can be used for multiple motors on the same drive, if the motors operate simultaneously. Size the reactor based upon the total horsepower of all the motors. Select a reactor with a current rating greater than the sum of the motor full-load currents. **Overload relays are recommended** for use in multi-motor applications.

Note: A single reactor should be used with multiple motors only when the motors will always operate simultaneously.

Single phase applications

Some of the line reactors are listed for use with single-phase input power. Make sure that terminals B1 and B2, if present, are properly insulated before any connections are made.



WARNING: Ensure that terminals B1 and B2 are properly insulated before making any connections to single-phase power.

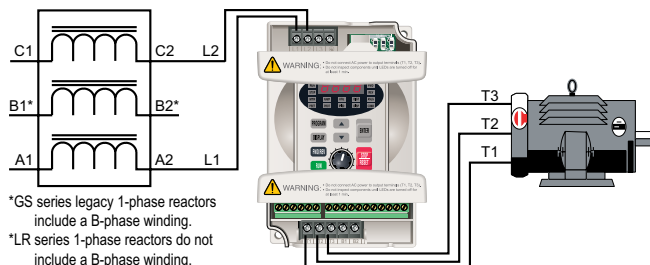

*GS series legacy 1-phase reactors include a B-phase winding.
*LR series 1-phase reactors do not include a B-phase winding.

GS/DURAPULSE Series AC Drives Optional Accessories

– Overview

GS/DURAPULSE Accessories
(not all accessories are applicable for every drive model)

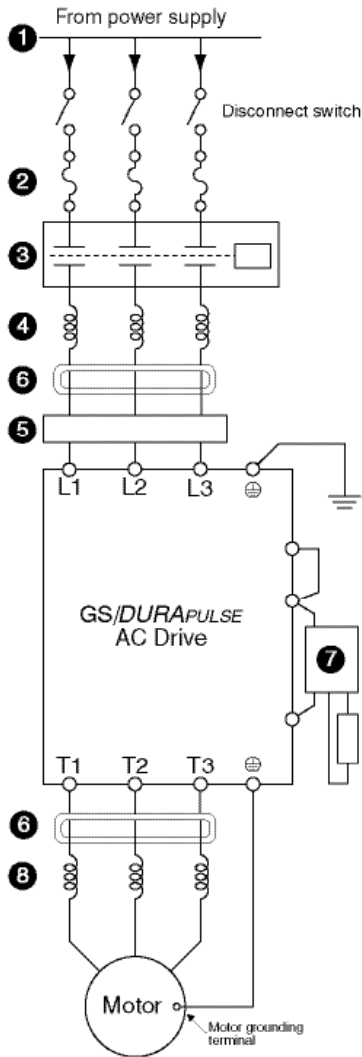

1 Power Supply

Please follow the specific power supply requirements shown in Chapter 1 of the applicable GS/DURAPULSE AC Drives User Manual (AutomationDirect.com).

2 Fuses

(See pages [tGSX-89](#), [tGSX-90](#), [pg.tGSX-92](#) for more information.)

Input fuses protect the AC drive from excessive input current due to line surges, short circuits, and ground faults. They are recommended for all installations and may be required for UL-listed installations.

3 Contactor (Optional)

(Contactors are available from AutomationDirect.com)

Do not use a contactor or disconnect switch for run/stop control of the AC drive and motor. This will reduce the operating life cycle of the AC drive. Cycling a power circuit switching device while the AC drive is in run mode should be done only in emergency situations.

4 Input Line Reactor (Optional)

(See pages [tGSx-74](#), [tGSX-50](#), and [tGSX-51](#) for more information.)

Input line reactors protect the AC drive from transient overvoltage conditions, typically caused by utility capacitor switching. The input line reactor also reduces the harmonics associated with AC drives. Input line reactors are recommended for all installations.

5 EMI filter (Optional)

(See pages [tDGA-29](#) and [tDGA-26](#) for more information.)

Input EMI filters reduce electromagnetic interference or noise on the input side of the AC drive. They are required for CE compliance and recommended for installations prone to or sensitive to electromagnetic interference.

6 RF filter (Optional)

(See page [tGSx-1](#) for more information.)

RF filters reduce the radio frequency interference or noise on the input or output side of the inverter.

7 Braking Unit and/or Braking Resistor (Optional)

(See pages [tGSX-77](#), [tGSX-50](#), [tGSX-79](#) for more information.)

Dynamic braking allows the AC drive to produce additional braking (stopping) torque. AC drives can typically produce between 15% & 20% braking torque without the addition of any external components. The addition of optional braking may be required for applications that require rapid deceleration or high inertia loads.

8 Output Load Reactor (Optional)

(See pages [tGSx-74](#), [tGSx-72](#), and [tGSX-51](#) for more information.)

Output line reactors protect the motor insulation against AC drive short circuits and IGBT reflective wave damage, and also “smooth” the motor current waveform, allowing the motor to run cooler. They are **recommended for operating “non-inverter-duty” motors and when the length of wiring between the AC drive and motor exceeds 75 feet.**