

# Black Max<sup>®</sup> Vector Duty Motors

\*\*\* 230/460V and 575V Motors Available \*\*\*



## Features

- Class F MAX GUARD<sup>®</sup> insulation system
- Constant torque operation from 0 to base speed on vector drive
- Constant horsepower operation to twice base RPM
- Continuous duty at 40° C ambient
- Optimized for operation with IGBT inverter (NEMA Design A)
- Class F N/C thermostats (one per phase)
- Utilizes double shielded ball bearings
- Exxon Polyrex<sup>®</sup> EM bearing grease
- C-Face with rigid base, except C-Face with removable rigid base as noted
- F1 standard conduit box location, field reversible to F2 (except as noted)
- Available with optional encoder installed on opposite drive end
- Electrically reversible
- UL Recognized, CSA Certified, and CE Mark
- Three year warranty (through Marathon Electric)

## Applications

- Designed for inverter or vector applications where up to a 1000:1 constant torque speed range is required.
- Typical uses include: material handling, machine tools, conveyors, crane and hoist, metal processing, test stands, pumps, compressors, textile processing, and other industrial machinery installed in dusty or dirty environments.

# Black Max<sup>®</sup> Vector Duty Motors

## Motor Shipping Schedule \*

Same or one day \*      Up to 7 days      Up to 10 days

Color indicates shipping lead time in business days. Check stock status online.

\* Certain heavy and oversized items can be shipped only via LTL. Check our website for current shipping method constraints by part number.

## 230/460V Motor Specifications

Part Number *	Price	HP	Base RPM	Volts	Enclosure	NEMA Frame	Model No.	F.L. Amps	Weight (lb) *	Footnotes
<b>Y592</b>		1/4	1800	230/460	TENV	56C	56H17T2001	1.2 / 0.6	19	T, S, 13
<b>Y534</b>		1/2	1800	230/460	TENV	56C	56H17T5301	1.6 / 0.8	28	T, S, 6, 13
<b>Y535</b>		1	1800	230/460	TENV	56C	56H17T5302	3.0 / 1.5	41	T, S, 6, 13
<b>Y536</b>		1	1800	230/460	TENV	143TC	143THTR5326	3.0 / 1.5	43	T, S, 6, 13
<b>Y537</b>		1	1200	230/460	TENV	145TC	145THTR5376	3.8 / 1.9	49	T, S, 6, 13
<b>Y538</b>		1-1/2	1800	230/460	TENV	145TC	145THTR5326	4.8 / 2.4	50	T, S, 6, 13
<b>Y551</b>		2	1800	230/460	TENV	145TC	145HTN6046	6.0 / 3.0	72	T, CI
<b>Y540</b>	6.00	2	1200	230/460	TENV	184TC	184HTL7776	6.6 / 3.3	88	T, AL
<b>Y541A</b>	8.00	3	1800	230/460	TENV	182TC	182HTY7726	8.2 / 4.1	110	T, AL
<b>Y542</b>	0.00	3	1200	230/460	TENV	213TC	213HTL7776	9.4 / 4.7	118	T, AL
<b>Y543A</b>		5	1800	230/460	TENV	184TC	184HTY7726	13.4 / 6.7	125	T, AL
<b>Y544</b>	7.50	5	1200	230/460	TENV	215TC	215HTL7776	15.4 / 7.7	138	T, AL
<b>Y545</b>	0.00	7-1/2	1800	230/460	TENV	213TC	213HTL7726	21.0 / 10.5	146	T, AL
<b>Y546</b>	2.50	7-1/2	1200	230/460	TENV	254TC	254HTL5776	22.0 / 11.0	209	T, AL
<b>Y547</b>	8.50	10	1800	230/460	TENV	215TC	215HTL7726	27.0 / 13.5	159	T, AL
<b>Y548</b>	9.50	10	1200	230/460	TENV	256TC	256HTL5776	28 / 14	203	T, AL
<b>Y549</b>	9.00	15	1800	230/460	TENV	254TC	254HTL5726	40 / 20	250	T, AL, I
<b>Y552</b>	5.50	20	1800	230/460	TENV	256TC	256HTNA7026	52 / 26	300	T, I, CI
<b>Y553</b>	9.00	25	1800	230/460	TENV	284TC	284HTNA7026	62 / 31	495	T, I, CI
<b>Y393</b>	5.50	30	1800	230/460	TENV	286TC	286HTNA7026	74 / 37	575	T, I, CI

\* Refer to the Motor Shipping Schedule table for shipping information.

**Footnotes:**

6 Bolt-on, removable base for footless mounting option  
 13 F1 Mounting Only, cannot modify to F2  
 AL Aluminum Frame Construction

**Footnotes (continued):**

CI Cast Iron Frame Construction  
 I Intermittent duty from 90-120 Hz operation  
 S Steel Frame Construction

**Footnotes (continued):**

T Thermostat overload

**Note:** Please review the AutomationDirect Terms & Conditions for warranty and service on his product.

Warranty service can be arranged through numerous Marathon Electric service centers. See list of service centers on our Web site at

# Black Max® Vector Duty Motors

## Motor Shipping Schedule \*

Same or one day \*      Up to 7 days      Up to 10 days

Color indicates shipping lead time in business days. Check stock status online.

\* Certain heavy and oversized items can be shipped only via LTL. Check our website for current shipping method constraints by part number.

## 575V Motor Specifications

Part Number	Price	HP	Base RPM	Volts	Enclosure	NEMA Frame	Model No.	F.L. Amps	Weight (lb)	Footnotes
<b>Y555</b>		1/2	1800	575	TENV	56C	56H17T5311	0.64	28	T, S, 6, 13
<b>Y556</b>		1	1800	575	TENV	56C	56H17T5312	1.2	41	T, S, 6, 13
<b>Y557</b>		2	1800	575	TENV	145TC	145THTN6060	2.4	72	T, CI
<b>Y558A</b>	8.00	3	1800	575	TENV	182TC	182THTY7736	3.3	110	T, AL
<b>Y559A</b>		5	1800	575	TENV	184TC	184THTY7736	5.4	125	T, AL
<b>Y560</b>	0.00	7-1/2	1800	575	TENV	213TC	213THTL7736	8.4	146	T, AL
<b>Y561</b>	8.50	10	1800	575	TENV	215TC	215THTL7736	10.8	159	T, AL
<b>Y562</b>	9.00	15	1800	575	TENV	254TC	254THTL5736	16.0	250	T, AL, I
<b>Y563</b>	5.50	20	1800	575	TENV	256TC	256THTNA7036	20.8	300	T, CI, I

**Footnotes:**  
 6 Bolt-on, removable base for footless mounting option  
 13 F1 Mounting Only, cannot modify to F2  
 AL Aluminum Frame Construction

**Footnotes (continued):**  
 CI Cast Iron Frame Construction  
 I Intermittent duty from 90-120 Hz operation  
 S Steel Frame Construction

**Footnotes (continued):**  
 T Thermostat overload

**Note: Please review the AutomationDirect Terms & Conditions for warranty and service on this product. Warranty service can be arranged through numerous Marathon Electric service centers. See list of service centers on our Web site at**

## Motor with Shaft-Mounted Encoder\*

A Dynapar Model HS35 shaft-mounted encoder can be supplied pre-installed on the motors as shown in the price table below. The encoder requires a 5–26 VDC power source, provides a count of 1024 pulses per revolution (PPR) differential line driver output, and includes a 10-pin mating connector.

\* If connecting the motor to a GS3 DURApulse AC drive, a [GS3-FB Feedback Card](#) is required for the drive.

## Motor Accessories

Part Number	Price	Description *
<b>A772</b>	3.00	Encoder kit, replacement, for Black Max encoder motors. Dynapar HS35 encoder, 5–26 VDC input, Line Driver output, 1024 pulses per revolution, 5/8-in bore.

\* Replacement/spare encoder kit for Black Max Yxxx-A772 motors; can also be field installed on Black Max Yxxx motors without encoders.

## Motor with Pre-installed Shaft-Mounted Encoder

230/460V Motors						575V Motors		
Part Number	Price	HP	Part Number	Price	HP	Part Number	Price	HP
<b>Y592-A772</b>	6.50	1/4	<b>Y592-A772</b>	6.50	5	<b>Y592-A772</b>	6.50	2
<b>Y534-A772</b>	8.50	1/2	<b>Y534-A772</b>	8.50	7-1/2	<b>Y534-A772</b>	8.50	3
<b>Y535-A772</b>	8.50	1	<b>Y535-A772</b>	8.50	7-1/2	<b>Y535-A772</b>	8.50	5
<b>Y536-A772</b>	1.00	1	<b>Y536-A772</b>	1.00	10	<b>Y536-A772</b>	1.00	7-1/2
<b>Y537-A772</b>	1.00	1	<b>Y537-A772</b>	1.00	10	<b>Y537-A772</b>	1.00	10
<b>Y538-A772</b>	9.00	1-1/2	<b>Y538-A772</b>	9.00	15	<b>Y538-A772</b>	9.00	15
<b>Y551-A772</b>	1.50	2	<b>Y551-A772</b>	1.50	20	<b>Y551-A772</b>	1.50	20
<b>Y540-A772</b>	5.00	2	<b>Y540-A772</b>	5.00	25	<b>Y540-A772</b>		
<b>Y541A-A772</b>	7.00	3	<b>Y541A-A772</b>	7.00	30			
<b>Y542-A772</b>	8.50	3	<b>Y542-A772</b>	8.50	1/2			
<b>Y543A-A772</b>	0.00	5	<b>Y543A-A772</b>	0.00	1			

**Note: Please review the AutomationDirect Terms & Conditions for warranty and service on this product. Warranty service can be arranged through numerous Marathon Electric service centers.**

# Black Max® Vector Duty Motors

## Encoder Connector Pinout

Note: A mating connector is supplied with the encoder. Prewired cables TRDA-25CBL-VWD-xx (10, 20, & 30 ft) and replacement MS connectors TRDA-25CON-VWD are available from AutomationDirect.

Dynapar HS35 Encoder PIN TRDA-25CBL-VWD-xx Cable Wire Color



Cable TRDA-25CBL-VWD-xx is available separately from AutomationDirect.

Connections to equipment determined by customer.

## Motor Performance Data (460 Volt) \*

Part Number	HP	F.L. rpm	F.L. Amps @460V	N.L. Amps @460V	F.L. Torque (lb-ft)	B.D. Torque (lb-ft)	Max. C hp rpm *	Max. Safe rpm	F.L. Effic. (%)	F.L. Power Factor	Rotor Inertia (lb-ft <sup>2</sup> )	Ohms/Ph - Equiv. Wye Circuit (460 VAC) (at rated operating temp. in 40° C ambient)				
												R1	R2	X1	X2	XM
<b>Y592</b>	1/4	1755	0.6	0.45	0.75	4.5	3540	5400	70.0	58.0	0.045	26.300	23.000	30.240	14.700	572.000
<b>Y534</b>	1/2	1735	0.8	0.52	1.5	5.8	3510	5400	80.0	72.0	0.056	22.307	17.028	24.123	18.163	532.976
<b>Y535</b>	1	1750	1.5	1.0	3.0	15.0	3505	5400	84.0	75.0	0.110	8.378	5.623	10.707	9.912	278.036
<b>Y536</b>	1	1750	1.5	1.0	3.0	15.0	3505	5400	84.0	75.0	0.110	8.378	5.623	10.707	9.912	278.036
<b>Y537</b>	1	1145	1.9	1.3	4.5	16.0	2260	5400	80.0	62.5	0.140	10.302	8.372	13.793	15.325	193.835
<b>Y538</b>	1-1/2	1755	2.4	1.6	4.5	29.0	3518	5400	85.5	69.0	0.140	4.257	3.538	5.998	5.884	161.009
<b>Y551</b>	2	1750	3.0	1.7	6.0	28.5	3525	5400	85.5	78.0	0.130	3.834	2.897	5.950	5.637	154.800
<b>Y540</b>	2	1160	3.3	2.1	9.0	34.0	2315	5400	82.5	67.5	0.380	3.948	3.436	7.725	12.113	116.900
<b>Y541A</b>	3	1755	4.1	2.3	9.0	49.3	3515	5400	87.5	78.5	0.420	1.578	1.802	2.838	2.091	94.13
<b>Y542</b>	3	1158	4.7	3.0	13.6	49.0	2300	4200	82.5	72.5	0.600	2.469	2.318	6.508	4.125	83.910
<b>Y543A</b>	5	1760	6.7	3.2	14.9	61.5	3520	5400	89.5	79	0.520	1.428	1.05	2.09	3.379	63.334
<b>Y544</b>	5	1165	7.7	4.8	22.5	87.0	2320	4200	84.0	71.0	0.900	1.130	1.250	3.709	2.573	51.972
<b>Y545</b>	7-1/2	1765	10.5	5.5	22.3	95.5	3525	4200	90.2	76.0	0.850	0.699	0.567	1.765	2.260	38.178
<b>Y546</b>	7-1/2	1170	11.0	6.0	34.0	118.0	2325	4200	87.5	73.0	1.200	0.510	0.680	2.846	3.247	42.714
<b>Y547</b>	10	1774	13.5	7.4	29.5	125.0	3540	4200	90.2	76.0	1.300	0.369	0.334	1.423	2.281	34.932
<b>Y548</b>	10	1160	14	7.0	45.5	135.0	2320	4200	89.5	75.5	1.500	0.534	0.693	2.258	2.323	30.530
<b>Y549</b>	15	1765	20	11.0	45.0	170.0	3550	4200	92.4	76.0	1.600	0.134	0.316	1.047	1.569	22.151
<b>Y552</b>	20	1768	26	13.5	59.5	290.0	3560	5400	93.6	80.0	3.100	0.234	0.213	0.746	0.689	18.204
<b>Y553</b>	25	1770	31	14.0	74.2	330.0	3530	3600	93.6	75.0	4.400	0.143	0.160	0.724	0.678	13.965
<b>Y393</b>	30	1772	37	23.5	89.0	375.0	3560	3600	94.5	74.0	5.500	0.113	0.123	0.543	0.557	11.200

\* Maximum Constant hp rpm is for direct coupled loads.

# Black Max<sup>®</sup> Vector Duty Motors

Motor Performance Data (575 Volt) *																
Part Number	HP	F.L. rpm	F.L. Amps @575V	N.L. Amps @575V	F.L. Torque (lb-ft)	B.D. Torque (lb-ft)	Max. C hp rpm*	Max. Safe rpm	F.L. Effic. (%)	F.L. Power Factor	Rotor Inertia (lb-ft <sup>2</sup> )	Ohms/Ph - Equiv. Wye Circuit (575 VAC) (at rated operating temp. in 40° C ambient)				
												R1	R2	X1	X2	XM
<b>Y555</b>	1/2	1735	0.8	0.8	1.52	5.8	3510	5400	80.0	72	0.056	22.307	17.028	24.123	18.163	532.976
<b>Y556</b>	1	1750	1.6	0.8	3.0	15.0	3505	5400	84.0	75	0.11	8.378	5.623	10.707	9.912	278.036
<b>Y557</b>	2	1750	2.4	1.6	6.0	28.5	3525	5400	85.5	78	0.13	3.834	2.897	5.950	5.637	154.780
<b>Y558A</b>	3	1755	3.3	1.8	9.0	49.3	3515	5400	87.5	78.5	0.42	1.578	1.802	2.838	2.091	94.13
<b>Y559A</b>	5	1760	5.4	2.6	14.9	61.5	3520	5400	89.5	79	0.52	1.4288	1.0489	2.092	3.379	63.3339
<b>Y560</b>	7-1/2	1765	8.0	4.8	22.3	95.5	3525	4200	90.2	76	0.9	0.699	0.567	1.765	2.260	38.178
<b>Y561</b>	10	1774	11.2	5.6	29.6	125.0	3540	4200	90.2	76	1.3	0.284	0.284	1.420	2.272	34.932
<b>Y562</b>	15	1765	16.0	8.8	44.6	170.0	3550	4200	92.4	76	1.6	0.314	0.316	1.047	1.569	22.151
<b>Y563</b>	20	1770	20.8	11.2	59.5	290.0	3560	3600	93.6	77	3.5	0.220	0.192	0.675	0.684	18.204

\* Maximum Constant hp rpm is for direct coupled loads.

# Black Max<sup>®</sup> Vector Duty Motors

## Motor Dimensions

N/A for NEMA frames 56C, 143TC, 145TC, which have the same C-face on both ends

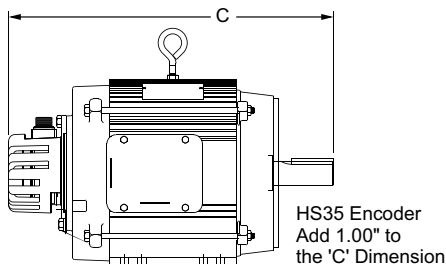
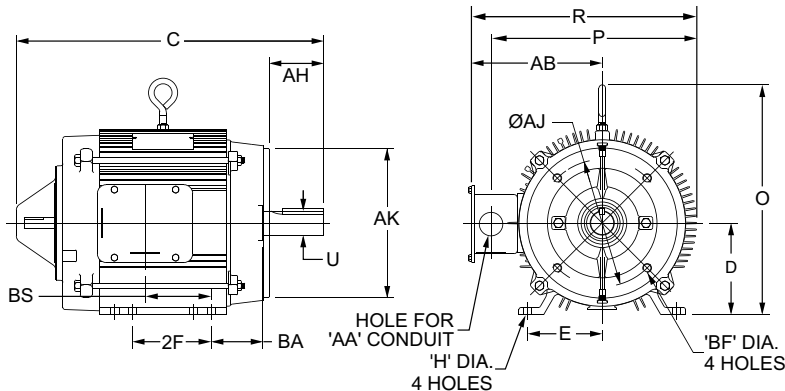
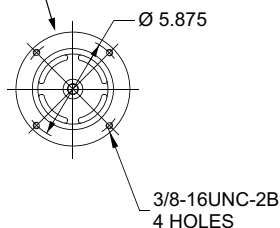

Note: Thermostat protector leads are brought out in the motor conduit box and marked as P1/P2.

**Black Max Vector Duty Motors Dimensions [Inches]**

Part #		NEMA Frame	Frame Construct	C	D	E	2F	H	O	P	R	U	AA	AB	AH	AJ	AK Max	BA	BF	BS	Key
230/460V	575V																				
Y592	-	56C	Rolled Steel	11.88	3.50	2.44	3.00	0.34	6.35	5.69	7.21	.625	None	4.37	2.06	5.875	4.500	2.75	3/8-16	2.84	.19x.19x1.38
Y534	Y555	56C	Rolled Steel	13.48	3.50	2.44	3.00	0.35	6.71	6.42	8.77	.625	None	5.56	2.06	5.875	4.500	2.75	3/8-16	3.75	.19x.19x1.38
Y535	Y556	56C	Rolled Steel	14.98	3.50	2.44	3.00	0.35	6.71	6.42	8.77	.625	None	5.56	2.06	5.875	4.500	2.75	3/8-16	5.25	.19x.19x1.38
Y536	-	143TC	Rolled Steel	15.04	3.50	2.75	4.00	0.35	6.71	6.42	8.46	.875	None	5.25	2.12	5.875	4.500	2.75	3/8-16	4.93	.19x.19x1.38
Y537	-	145TC	Rolled Steel	16.04	3.50	2.75	5.00	0.35	6.71	6.42	8.46	.875	None	5.25	2.12	5.875	4.500	2.75	3/8-16	5.93	.19x.19x1.38
Y538	-	145TC	Rolled Steel	16.04	3.50	2.75	5.00	0.35	6.71	6.42	8.46	.875	None	5.25	2.12	5.875	4.500	2.75	3/8-16	5.93	.19x.19x1.38
Y551	Y557	145TC	Cast Iron	14.68	3.50	2.75	5.00	0.37	7.45	7.98	11.03	.875	None	7.04	2.12	5.875	4.500	2.62	3/8-16	3.81	.19x.19x1.38
Y541A	-	182TC	Aluminum	16.19	4.50	3.75	4.50	0.43	10.44	10.13	11.40	1.1250	1.13	6.49	2.62	7.25	8.500	3.50	1/2-13	3.0	.25x.25x1.75
-	Y558A	182TC	Aluminum	16.19	4.50	3.75	4.50	0.43	10.44	10.13	11.40	1.1250	1.13	6.49	2.62	7.25	8.500	3.50	1/2-13	3.00	.25x.25x1.75
Y540	-	184TC	Aluminum	16.94	4.50	3.75	5.50	0.44	11.22	9.74	12.07	1.125	1.09	7.19	2.62	7.25	8.500	3.50	1/2-13	2.75	.25x.25x1.75
Y543A	-	184TC	Aluminum	17.69	4.50	3.75	5.50	0.43	10.44	10.13	11.40	1.1250	1.13	6.49	2.62	7.25	8.500	3.50	1/2-13	3.75	.25x.25x1.75
-	Y559A	184TC	Aluminum	17.69	4.50	3.75	5.50	0.43	10.44	10.13	11.40	1.1250	1.13	6.49	2.62	7.25	8.500	3.50	1/2-13	3.75	.25x.25x1.75
Y542	-	213TC	Aluminum	19.04	5.22	4.25	5.50	0.47	12.47	10.75	12.78	1.375	1.34	7.39	3.12	7.25	8.500	4.25	1/2-13	4.05	.31x.31x2.38
Y545	Y560	213TC	Aluminum	20.54	5.22	4.25	5.50	0.47	12.47	10.75	12.78	1.375	1.34	7.39	3.12	7.25	8.500	4.23	1/2-13	5.55	.31x.31x2.38
Y544	-	215TC	Aluminum	20.54	5.22	4.25	7.00	0.47	12.47	10.75	12.78	1.375	1.34	7.39	3.12	7.25	8.500	4.23	1/2-13	5.55	.31x.31x2.38
Y547	Y561	215TC	Aluminum	23.04	5.22	4.25	7.00	0.47	12.47	10.75	12.78	1.375	1.34	7.39	3.12	7.25	8.500	4.25	1/2-13	8.05	.31x.31x2.38
Y546	-	254TC	Aluminum	25.37	6.22	5.00	8.25	0.56	13.46	10.75	13.75	1.625	1.75 & 2.0	8.38	3.75	7.25	8.500	4.25	1/2-13	8.85	.38x.38x2.88
Y549	Y562	254TC	Aluminum	26.87	6.22	5.00	8.25	0.56	13.46	N/A	13.54	1.625	1.75 & 2.0	8.17	3.75	7.25	8.500	4.75	1/2-13	10.40	.38x.38x2.88
Y548	-	256TC	Aluminum	26.87	6.22	5.00	10.00	0.56	13.46	N/A	13.54	1.625	1.75 & 2.0	8.17	3.75	7.25	8.500	4.75	1/2-13	10.40	.38x.38x2.88
Y552	Y563	256TC	Cast Iron	27.13	6.22	5.00	10.00	0.56	16.49	14.32	17.84	1.625	1.25	10.68	3.79	7.25	8.500	4.75	1/2-13	4.75	.38x.38x2.88
Y553	-	284TC	Cast Iron	27.08	7.00	5.50	9.50	0.56	15.57	15.89	21.26	1.875	2.00	13.31	4.38	9.0	10.500	4.75	1/2-13	4.75	.50x.50x3.25
Y393	-	286TC	Cast Iron	28.58	7.00	5.50	11.00	0.56	15.57	15.89	21.26	1.875	2.00	13.31	4.38	9.0	10.500	4.75	1/2-13	5.50	.50x.50x3.25

Note: Dimensions are for reference only. For complete dimensional information, refer to Marathon Electric at [www.marathonelectric.com](http://www.marathonelectric.com).

# STABLE™ Motor Slide Bases

## Mounting Slide Bases for 56 to 449T NEMA Motors Features

- Allows adjustment of motor mounting position
- Slide direction is perpendicular to motor shaft
- Double adjusting screws for frames 182T-449T
- Manufactured to precise dimensional standards
- Dimensionally interchangeable with existing major makes
- Heavy-duty steel construction
- Painted with oven-baked primer for better adhesion of customer's paint
- All "D" bolts (motor mounting bolts) are fixed to the exact motor foot pattern
- All "D" bolts are welded into position to prevent spinning and dropping from slots
- Nuts and washers are provided for securing the motor to the slide base



STABLE Motor Slide Bases for 3-Phase Motors										
Part Number	Price	Fits Frame Type	Product Wt. (lb)	Fits Motor						
				IronHorse	Marathon					
					micro -MAX ---- Max+	Black Max 230/460V ---- Black Max 575V	Blue Max	XRI GP & NEMA Premium	Powerwash SXT & Jet Pump	Blue Chip XRI 230/460V ---- Blue Chip XRI 575V
<b><u>MTA-BASE-W56 *</u></b>		56*	2.8	MTPM-P3x-1x18 MTPM-P5x-1x18 MTPM-P7x-1x18 MTPM-0xx-1x18 MTPM-1xx-1x18 MTR(2)(P)-xxx-xxxxx*	<a href="#">Y500</a> <a href="#">Y502</a> <a href="#">Y360</a> <a href="#">Y362</a> <a href="#">Y364</a> <a href="#">Y280</a> <a href="#">Y281</a> <a href="#">Y282</a>	<a href="#">Y592(-A772)</a> <a href="#">Y534(-A772)</a> <a href="#">Y535(-A772)</a> <a href="#">Y555(-A772)</a> <a href="#">Y556(-A772)</a>	-	<a href="#">E2000</a> <a href="#">D390</a> <a href="#">G580</a> <a href="#">D391</a> <a href="#">G581</a> <a href="#">K705</a> <a href="#">D392</a> <a href="#">G582</a> <a href="#">K707</a> <a href="#">D393A</a> <a href="#">K708A</a> <a href="#">G583A</a> <a href="#">K709A</a> <a href="#">D394A</a> <a href="#">K721A</a> <a href="#">G584A</a> <a href="#">D395A</a> <a href="#">G585A</a> <a href="#">K724A</a> <a href="#">D396A</a> <a href="#">K725A</a>	<a href="#">N410</a> <a href="#">J066A</a>	-
<b><u>MTA-BASE-W143T</u></b>		143T/TC	4.6	<a href="#">MTC2-001-3BD18(C)</a> <a href="#">MTC2-1P5-3BD36</a>	-	<a href="#">Y536(-A772)</a>	-	<a href="#">E2001A</a> <a href="#">E2003</a>		-
<b><u>MTA-BASE-W145T</u></b>		145T/TC	5.1	<a href="#">MTC2-001-3BD12</a> <a href="#">MTC2-1P5-3BD18(C)</a> <a href="#">MTC2-002-3BD18(C)</a> <a href="#">MTC2-002-3BD36</a>	<a href="#">Y366</a> <a href="#">Y368</a> <a href="#">Y284</a> <a href="#">Y285</a>	<a href="#">Y537(-A772)</a> <a href="#">Y538(-A772)</a> <a href="#">Y551(-A772)</a> <a href="#">Y557(-A772)</a>	-	<a href="#">E2002</a> <a href="#">E2004A</a> <a href="#">E2007A</a>		-
<b><u>MTA-BASE-W182T</u></b>		182T/TC	9.2	<a href="#">MTC2-1P5-3BD12</a> <a href="#">MTC2-003-3BD18(C)</a> <a href="#">MTC2-003-3BD36</a> <a href="#">MTF-002-1C18-182</a>	<a href="#">Y1999</a> <a href="#">Y286A</a>	<a href="#">Y541A(-A772)</a> <a href="#">Y558A(-A772)</a>	-	<a href="#">E2009</a> <a href="#">E2010</a>	<a href="#">C383B</a>	-

\* IronHorse MTR2 56HC motors have double-punched bases to fit on slide base [MTA-BASE-W56](#).

\*\* Motors [MTC-250-3D18](#) and [MTC-300-3D18](#) are obsolete, and no longer available.

table continued on next page

# STABLE™ Motor Slide Bases

table continued from previous page

STABLE Motor Slide Bases for 3-Phase Motors										
Part Number	Price	Fits Frame Type	Product Wt. (lb)	Fits Motor						
				IronHorse	Marathon					Blue Chip XRI 230/460V ---- Blue Chip XRI 575V
					micro-MAX ---- Max +	Black Max 230/460V ---- Black Max 575V	Blue Max	XRI GP & NEMA Premium	Powerwash SXT & Jet Pump	
<a href="#">MTA-BASE-W184T</a>		184T/TC	10	<a href="#">MTCP2-002-3BD12</a> <a href="#">MTCP2-005-3BD18(C)</a> <a href="#">MTCP2-005-3BD36</a> <a href="#">MTF-00x-1C18</a>	<a href="#">Y1372</a> <a href="#">Y287A</a>	<a href="#">Y540(-A772)</a> <a href="#">Y543A(-A772)</a> <a href="#">Y559A(-A772)</a>	-	<a href="#">E2012</a> <a href="#">E2013</a>	<a href="#">C387B</a>	-
<a href="#">MTA-BASE-W213T</a>		213T/TC	13	<a href="#">MTCP2-003-3BD12</a> <a href="#">MTCP2-7P5-3BD18(C)</a> <a href="#">MTCP2-7P5-3BD36</a>	<a href="#">Y994</a>	<a href="#">Y542(-A772)</a> <a href="#">Y545(-A772)</a> <a href="#">Y560(-A772)</a>	-	<a href="#">E2011</a> <a href="#">E2016A</a>	<a href="#">C389B</a> <a href="#">C390B</a> <a href="#">C391B</a> <a href="#">E2011A</a> <a href="#">E2016B</a>	-
<a href="#">MTA-BASE-W215T</a>		215T/TC	15	<a href="#">MTCP2-005-3BD12</a> <a href="#">MTCP2-010-3BD18(C)</a> <a href="#">MTCP2-010-3BD36</a>	<a href="#">Y996</a>	<a href="#">Y544(-A772)</a> <a href="#">Y547(-A772)</a> <a href="#">Y561(-A772)</a>	-	<a href="#">E2018</a>	<a href="#">C392B</a> <a href="#">E2014A</a> <a href="#">E2018A</a>	-
<a href="#">MTA-BASE-W254T</a>		254T/TC	18	<a href="#">MTCP2-7P5-3BD12</a> <a href="#">MTCP2-015-3BD18(C)</a> <a href="#">MTCP2-015-3BD36</a>	-	<a href="#">Y546(-A772)</a> <a href="#">Y549(-A772)</a> <a href="#">Y562(-A772)</a>	-	-	-	-
<a href="#">MTA-BASE-W256T</a>		256T/TC	19	<a href="#">MTCP2-010-3BD12</a> <a href="#">MTCP2-020-3BD18(C)</a> <a href="#">MTCP2-20-3BD36</a>	-	<a href="#">Y548(-A772)</a> <a href="#">Y552(-A772)</a> <a href="#">Y563(-A772)</a>	-	-	-	-
<a href="#">MTA-BASE-W284T</a>		284T/TC	20	<a href="#">MTCP2-015-3BD12</a> <a href="#">MTCP2-025-3BD18(C)</a>	-	<a href="#">Y553(-A772)</a>	-	-	-	<a href="#">E207</a>
<a href="#">MTA-BASE-W286T</a>		286T/TC	21	<a href="#">MTCP2-20-3BD12</a> <a href="#">MTCP2-030-3BD18(C)</a>	-	<a href="#">Y393(-A772)</a>	-	-	-	-
<a href="#">MTA-BASE-W324T</a>		324T/TC	30	<a href="#">MTCP2-040-3BD18(C)</a>	-	-	<a href="#">Y571(-A774)</a> <a href="#">Y513(-A775)</a>	-	-	<a href="#">E209</a>
<a href="#">MTA-BASE-W326T</a>		326T/TC	31	<a href="#">MTCP2-050-3BD18(C)</a>	-	-	<a href="#">Y572(-A774)</a> <a href="#">Y514(-A775)</a>	-	-	-
<a href="#">MTA-BASE-W364T</a>		364T/TC	43	<a href="#">MTCP2-060-3BD18(C)</a>	-	-	<a href="#">Y573(-A774)</a> <a href="#">Y515(-A775)</a>	-	-	-
<a href="#">MTA-BASE-W365T</a>		365T/TC	43	<a href="#">MTCP2-075-3BD18(C)</a>	-	-	<a href="#">Y574(-A774)</a> <a href="#">Y516(-A775)</a>	-	-	<a href="#">E212</a>
<a href="#">MTA-BASE-W404T</a>		404T/TC	58	-	-	-	-	-	-	-
<a href="#">MTA-BASE-W405T</a>		405T/TC	60	<a href="#">MTCP2-100-3BD18(C)</a>	-	-	<a href="#">Y575(-A774)</a> <a href="#">Y517(-A775)</a>	-	-	-
<a href="#">MTA-BASE-W444T</a>		444T	63	<a href="#">MTCP2-125-3BD18</a>	-	-	-	-	-	-
<a href="#">MTA-BASE-W445T</a>		445T	65	<a href="#">MTCP2-150-3BD18</a>	-	-	-	-	-	-
<a href="#">MTA-BASE-W447T</a>		447T	89	<a href="#">MTCP2-200-3BD18</a>	-	-	-	-	-	-
<a href="#">MTA-BASE-W449T</a>		449T	94	<a href="#">MTCP2-250-3D18</a> <a href="#">MTCP2-300-3D18</a>	-	-	-	-	-	-

\* IronHorse MTR2 56HC motors have double-punched bases to fit on slide base [MTA-BASE-W56](#).



# AutomationDirect AC Motors Selection Overview

## General-purpose or inverter-duty motor?

### How to choose a general purpose motor vs. an inverter-duty motor

General purpose motors have been around for many years. They are the workhorse of almost every industry. An inverter-duty motor is a much newer concept that was necessary as general purpose motors began to be driven by VFDs (inverters or AC drives). An inverter duty motor can withstand the higher voltage spikes produced by all VFDs (amplified at longer cable lengths) and can run at very slow speeds without overheating. This performance comes at a cost: inverter-duty motors can be much more expensive than general purpose motors. Guidelines for choosing an IronHorse general purpose motor vs. an inverter-duty motor are given below. If your application falls within the guidelines below, there is no need to apply an inverter-duty motor.

NOTE: Marathon inverter-duty motors have limitations as well. Please see the Marathon section for more details.

**Background:** For many years, AC motors were driven by across-the-line contactors and starters. The electricity sent to the motor was a very clean sine wave at 60Hz. Noise and voltage peaks were relatively small. However, there were drawbacks: they only ran electrically at one speed (speed reduction was usually handled by gearboxes or some other, usually inefficient, mechanical means) and they had an inrush of electrical current (when the motor was first turned on) that was usually 5 to 6 times the normal current that the motor would consume. The speed reduction apparatus was expensive and bulky, and the inrush would wreak havoc with power systems and loading (imagine an air conditioning system in an old house - when the compressor would kick on, the lights would dim; now imagine the same circumstances with a motor the size of a small car).

**Note: The following discussion applies only to 3-phase motors.**

**Enter the VFDs (variable frequency drives):**

Drives were introduced to allow the speed of these motors to be changed while running and to lessen the inrush current when the drive first starts up. To do this, the drive takes the incoming 60Hz AC power and rectifies it to a DC voltage (every drive has a DC bus that is around  $1.414 \text{ (sqrt of 2) * incoming AC Line Voltage}$ ).

This DC voltage is then "chopped" by power transistors at very high frequencies to simulate a sine wave that is sent to the motor [see Figure 1]. By converting the incoming power to DC and then reconverting it to AC, the drive can vary its output voltage and output frequency, thus varying the speed of a motor. Everything sounds great, right? We get to control the frequency and voltage going out to the motor, thus controlling its speed.

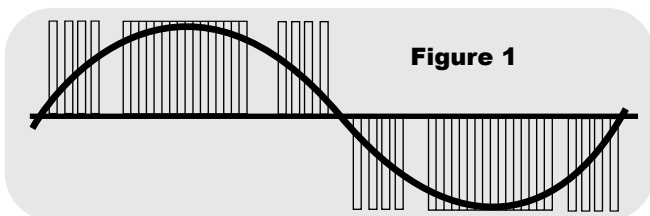

Figure 1

**Some things to watch out for:** A VFD-driven general purpose motor can overheat if it is run too slowly. (Motors can get hot if they're run slower than their rated speed.) Since most general purpose motors cool themselves with shaft-mounted fans, if the motor overheats, bearing and insulation life will be reduced. Therefore there are minimum speed requirements for all motors.

The voltage "chopping" that occurs in the drive actually sends high-voltage spikes (at the DC bus level) down the wire to the motor. If the system contains long cabling, there are actually instances where a reflected wave occurs at the motor. The reflected wave can effectively double the voltage on the wire. This can lead to premature failure of the motor insulation. Long cable lengths between the motor and drive increase the harmful effects of the reflected wave, as do high chopping frequencies (listed in drive manuals as carrier frequencies).

Line reactors, 1:1 transformers placed at the output of the drive, can help reduce the voltage spikes going from the drive to the motor. Line reactors are used in many instances when the motor is located far from the drive [see Figure 2].

In summary, general purpose motors can be run with drives in many applications; however inverter-duty motors are designed to handle much lower speeds without overheating and they are capable of withstanding higher voltage spikes without their insulation failing. With the increased performance comes an increase in cost. This additional cost can be worth it if you need greater performance.

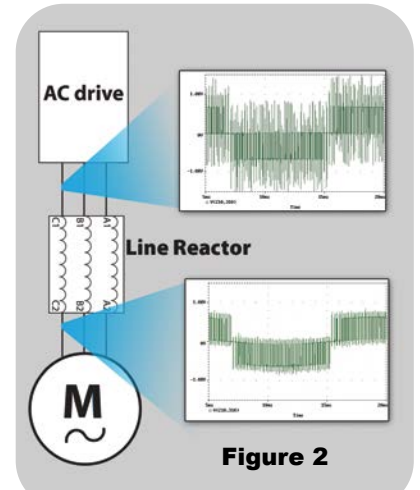

Figure 2

The considerations for applying IronHorse motors are given below.

### Heat considerations

	IronHorse speed ratio	For an 1800 RPM motor, minimum IronHorse speed is:
Variable Torque applications (fans, centrifugal pumps, etc.)	5:1 (EPA motors) 10:1 (PE motors)	1800/5 = 360RPM 1800/5 = 180RPM
Constant Torque Applications (conveyors, extruders, etc.)	2:1 (EPA motors) 4:1 (PE motors)	1800/2 = 900RPM 1800/4 = 450RPM

### Voltage Spike considerations

	Max cable distance from drive to IronHorse motor	Max cable distance with a 3% line reactor between drive and IronHorse motor
For use with 230V and 460V VFDs*	125 ft	250 ft

\* Up to 6kHz carrier frequency