



A-Series Pneumatic Cylinders 9/16 inch Bore Accessories

A-Series Pneumatic Cylinder 9/16 inch Bore Accessories				
Part Number	Description	Pcs/Pkg	Wt (lb)	Price
AMB-4	Cylinder mounting bracket used to mount 7/16 and 9/16 inch bore NITRA pneumatic stainless steel round body, interchangeable, non-repairable cylinders.	1	0.1	
ARC-10-32	Cylinder rod clevis and hex nut, #10-32 thread, for use with 7/16 and 9/16 inch bore NITRA pneumatic stainless steel round body, interchangeable, non-repairable cylinders.	1	0.1	
APBP-2	Cylinder pivot mounting bracket with pivot pin used to mount 9/16 inch bore NITRA pneumatic stainless steel round body, interchangeable, non-repairable cylinders.	1	0.1	
AN-716-20	Cylinder mounting nut with 7/16-20 UNF-2B threads used to mount 7/16 inch and 9/16 inch bore NITRA pneumatic stainless steel round body, interchangeable, non-repairable cylinders.	1	0.2	

Dimensions

inches [mm]

AMB-4

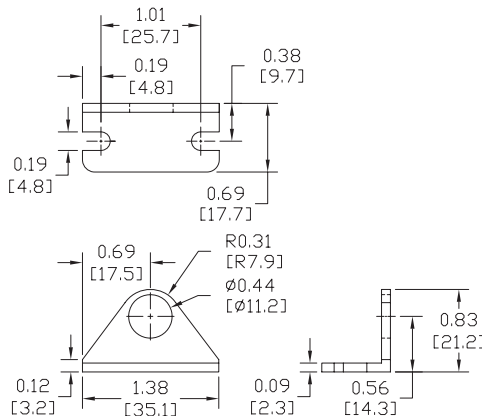

ARC-10-32

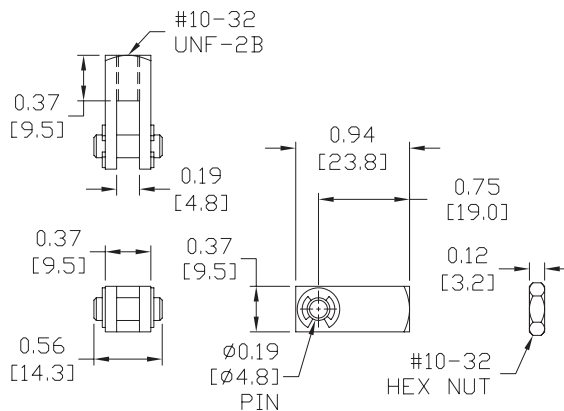

A-Series Pneumatic Cylinders 9/16 inch Bore Accessories

Dimensions

inches [mm]

APBP-2

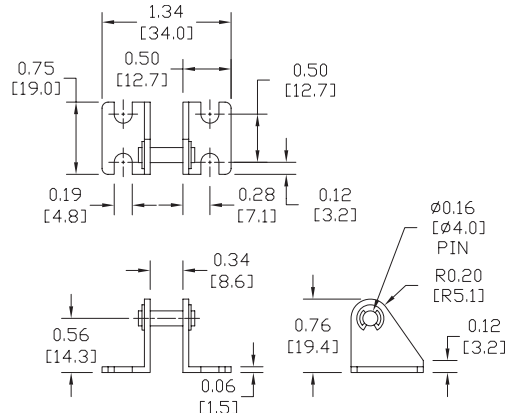

AN-716-20

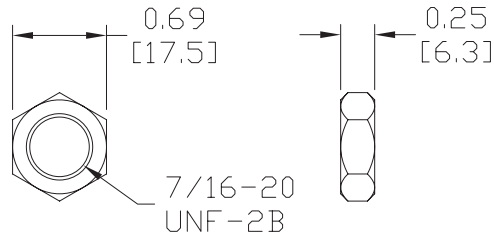



Pneumatic Cylinders - A-Series

Nitra A-Series Pneumatic Stainless Steel Round Body Air Cylinders

The NITRA Pneumatics A-Series non-repairable stainless steel round body cylinders includes bore sizes from 7/16" to 2" and stroke lengths from 1/2" to 18" to meet a broad range of applications. These high quality cylinders are constructed with stainless steel bodies and double rolled-in high strength aluminum end caps with full flow ports. To minimize friction the inside of the cylinder body is polished to a mirror finish and all cylinders are factory lubricated for optimum performance and long, reliable life. The high strength aluminum alloy piston is securely threaded and sealed to a piston rod that is ground and roller burnished 303 stainless steel (7/16" and 9/16" bores) or ground and polished high strength steel (3/4" – 2" bores) with roll-formed threads for exceptional strength. Low friction wear compensating Buna N U-cup rod and piston seals, sintered bronze rod guide bushing (except 7/16" and 9/16" bores), and end caps with slots all combine for smooth breakaway even at low pressures.

Features

- Interchangeable with other common brands of round body cylinders
- Available bore sizes: 7/16", 9/16", 3/4", 7/8", 1-1/16", 1-1/4", 1-1/2", 2"
- Excellent selection of stroke lengths
- Single-acting (spring return) and double-acting models
- Nose, pivot and double-end mounting options
- Type 304 stainless steel body with high-strength aluminum alloy end caps
- Factory lubricated for long, maintenance-free operation
- 250 psi operating pressure
- Models available with magnetic piston for position indication
- All models are available for same-day shipment
- Made in North America
- 3-year warranty

Operation

Single-acting cylinders with spring return have one compressed air port to extend the rod in the "push" direction. The internal spring retracts in the "pull" direction.

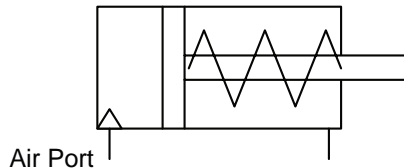

*Single-Acting Cylinder with Spring Return
(Force in Push Direction)*

Double-acting cylinders have two compressed air ports. One of the ports will extend the rod in the "push" direction and the other port will retract the rod in the "pull" direction.

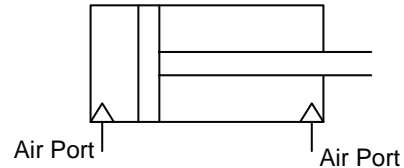

*Double-Acting Cylinder
(Force in Push and Pull Direction)*

Mounting Options



Nose mount uses one AMB bracket and one AN nut.



Pivot mount uses one APB or one APBP bracket.



Double end mount uses two AMB brackets and two AN nuts.

Cylinder Features

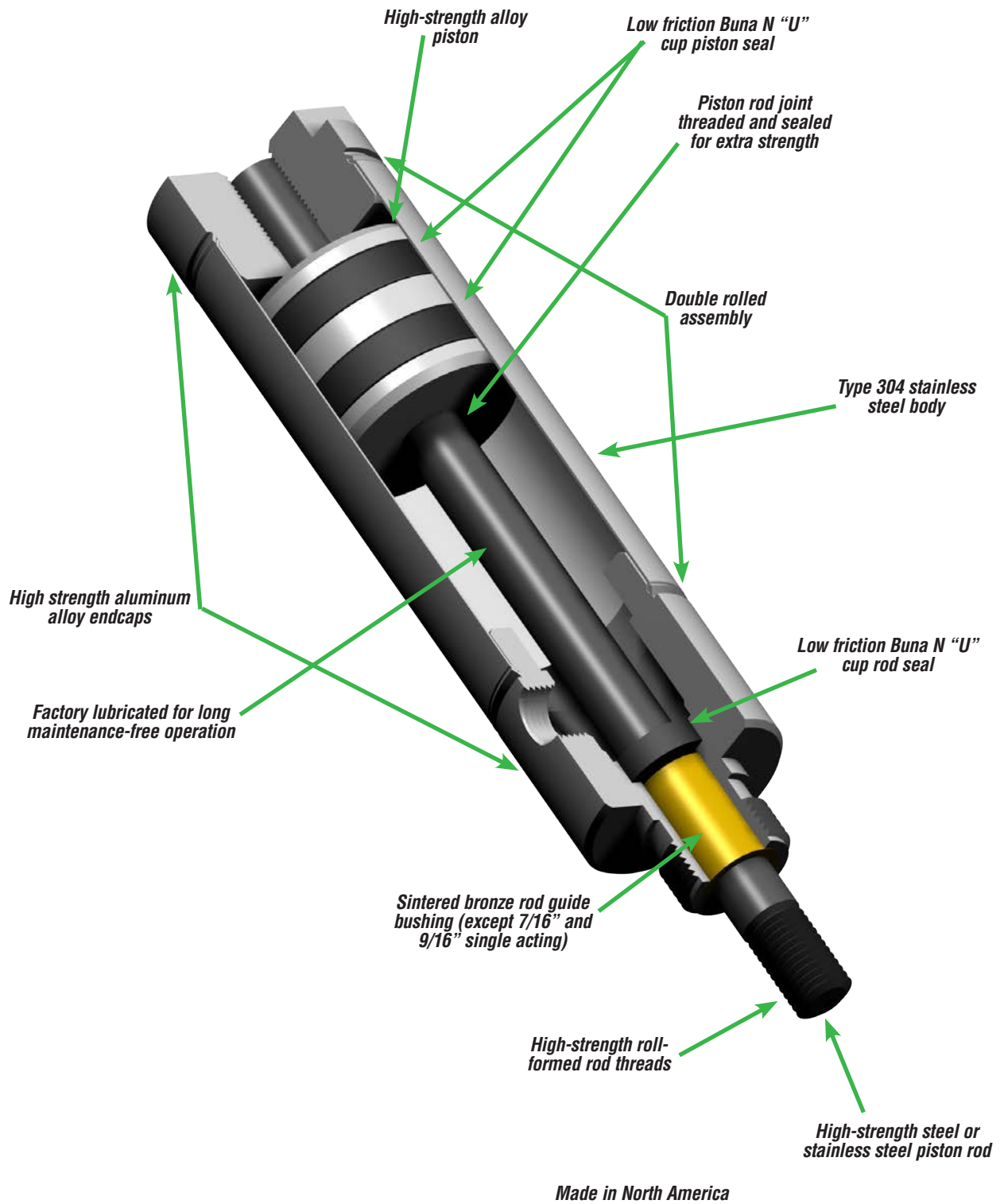

Position Switch Cross Reference Chart			
NITRA Switch Type	Cylinder Brand (may fit some of these cylinders)	Photo Example	Groove Illustration
CPS CPSF	NITRA A-Series, D-Series, F-Series		
CPS9C	DE-STA-CO Robohand SMC Compact Air		
CPS9D	Fabco Numatics Rotomation		
CPS9F	NITRA G-Series Fabco Festo Numatics Rotomation		
CPS9H	NITRA E-Series NITRA H-Series		
CPS9M	Norgren		
CPS9Q	NITRA G-Series Parker		
CPS9T	SMC		