



D2-Series Heavy Duty Pneumatic Cylinders – 1-1/2 inch Bore

1-1/2 in. Bore, Double-acting, Tapped End Caps, Magnetic Piston



Part no. D224030DT-M

NITRA heavy duty pneumatic, NFPA interchangeable cylinder, 1-1/2" bore, 5/8" diameter piston rod, 7/16"-20 male threaded end, 1/4" female NPT ports, double acting, tapped end caps and one side for mount; flange, pivot and clevis mount options available. Some models available with cushions on both ends.

1-1/2 in bore, double acting, tapped end caps							
Part Number no Cushions	Price	Drawing Link	Part Number w/ Cushions*	Price	Drawing Link	Stroke Length (in)	Weight (lb)
D224010DT-M		PDF	D224010DT-MC		PDF	1	1.5
D224020DT-M		PDF	D224020DT-MC		PDF	2	1.7
D224030DT-M		PDF	D224030DT-MC		PDF	3	1.9
D224040DT-M		PDF	D224040DT-MC		PDF	4	2.2
D224050DT-M		PDF	D224050DT-MC		PDF	5	2.4
D224060DT-M		PDF	D224060DT-MC		PDF	6	2.6
D224070DT-M		PDF	D224070DT-MC		PDF	7	2.8
D224080DT-M		PDF	D224080DT-MC		PDF	8	3.0
D224100DT-M		PDF	D224100DT-MC		PDF	10	3.5
D224120DT-M		PDF	D224120DT-MC		PDF	12	3.9
D224140DT-M		PDF	D224140DT-MC		PDF	14	4.4
D224160DT-M		PDF	D224160DT-MC		PDF	16	4.8
D224180DT-M		PDF	D224180DT-MC		PDF	18	5.3
D224200DT-M		PDF	D224200DT-MC		PDF	20	5.7
D224220DT-M		PDF	D224220DT-MC		PDF	22	6.1
D224240DT-M		PDF	D224240DT-MC		PDF	24	6.6
D224280DT-M		PDF	D224280DT-MC		PDF	28	7.1
D224320DT-M		PDF	D224320DT-MC		PDF	32	7.5

* The cushions decelerate the piston rod over the last 11/16 inch (approx.) of stroke and are adjustable. Cushioned cylinders have an adjustable orifice and pre-lubricated nitrile cushion seal.

Specifications	
Aluminum hard anodized to 60 Rc cylinder body	1.77 sq. in. piston area
Solid aluminum bar, black anodized end caps	Pressure rating 250 psi, AIR ONLY
High tensile ground and polished hard chrome plated steel piston rod	Non-detergent petroleum based oil is recommended
Low friction Buna-N seals	Temperature range -20°F to 200°F (-25 to 90°C)
Extend force at 100 psi = 177 lb.	Retract force at 100 psi = 146 lb.
Filtration: Not essential, however a standard 40 micron filter placed upstream will prolong seal life.	

Mounting Accessories		
Style	NFPA Designation	Part No.
Front Flange	MF1	D2FM-1
Rear Flange	MF2	D2FM-1
Rear Clevis	MP2	D2PC-1
Rear Clevis Short	MP1	D2SPC-1
Rear Pivot	MP4	D2PA-1
Angle Mount	MS1	D2AM-1
Base Mount	None	D2BB-1

Rod Accessories	
Style	Part No.
Rod Clevis	D2RC-1
Rod Eye	D2RE-1
Rod Couplers	D2RCP-1
Rod Nuts	D2-716-20
Seal Kit	D2SK-24

D2-Series Heavy Duty Pneumatic Cylinders – Accessories

Rod Clevis



Part no. D2RC-2



Note: Comes with Pivot Pin installed.

D2-Series Heavy Duty Pneumatic Cylinder Accessories					
Part Number	Description	Pcs/Pkg	Wt (lb)	Price	Drawing Link
D2RC-1	NITRA rod clevis, 7/16-20 UNF thread, steel. For use with D2 series NFPA cylinders.	1	0.3		PDF
D2RC-2	NITRA rod clevis, 3/4-16 UNF thread, steel. For use with D2 series NFPA cylinders.	1	0.8		PDF

Rod Eye



Part no. D2RE-2

D2-Series Heavy Duty Pneumatic Cylinder Accessories					
Part Number	Description	Pcs/Pkg	Wt (lb)	Price	Drawing Link
D2RE-1	NITRA rod eye, 7/16-20 UNF thread, steel. For use with D2 series NFPA cylinders.	1	0.4		PDF
D2RE-2	NITRA rod eye, 3/4-16 UNF thread, steel. For use with D2 series NFPA cylinders.	1	1.2		PDF

D2-Series Heavy Duty Pneumatic Cylinders – Accessories

Rear Clevis



Part no. D2PC-3



Part no. D2SPC-3



Note: Comes with pivot pin installed.

D2-Series Heavy Duty Pneumatic Cylinder Accessories

Part Number	Description	Pcs/Pkg	Wt (lb)	Price	Drawing Link
D2PC-1	NITRA cylinder rear clevis bracket, steel. For use with 1.5in bore D2 series NFPA cylinders. Mounting hardware included.	1	0.5		PDF
D2PC-2	NITRA cylinder rear clevis bracket, steel. For use with 2in bore D2 series NFPA cylinders. Mounting hardware included.	1	0.7		PDF
D2PC-3	NITRA cylinder rear clevis bracket, steel. For use with 2.5in bore D2 series NFPA cylinders. Mounting hardware included.	1	0.8		PDF
D2PC-4	NITRA cylinder rear clevis bracket, steel. For use with 3.25in bore D2 series NFPA cylinders. Mounting hardware included.	1	1.6		PDF
D2PC-5	NITRA cylinder rear clevis bracket, steel. For use with 4in bore D2 series NFPA cylinders. Mounting hardware included.	1	1.7		PDF
D2SPC-1	NITRA cylinder rear short clevis bracket, steel. For use with 1.5in bore D2 series NFPA cylinders. Mounting hardware included.	1	0.7		PDF
D2SPC-2	NITRA cylinder rear short clevis bracket, steel. For use with 2in bore D2 series NFPA cylinders. Mounting hardware included.	1	0.7		PDF
D2SPC-3	NITRA cylinder rear short clevis bracket, steel. For use with 2.5in bore D2 series NFPA cylinders. Mounting hardware included.	1	0.8		PDF
D2SPC-4	NITRA cylinder rear short clevis bracket, steel. For use with 3.25in bore D2 series NFPA cylinders. Mounting hardware included.	1	2.4		PDF
D2SPC-5	NITRA cylinder rear short clevis bracket, steel. For use with 4in bore D2 series NFPA cylinders. Mounting hardware included.	1	3.2		PDF

Rear Pivot Eye



Part no. D2PA-3

D2-Series Heavy Duty Pneumatic Cylinder Accessories

Part Number	Description	Pcs/Pkg	Wt (lb)	Price	Drawing Link
D2PA-1	NITRA rear pivot eye, steel. For use with 1.5in bore D2 series NFPA cylinders. Mounting hardware included.	1	0.4		PDF
D2PA-2	NITRA rear pivot eye, steel. For use with 2in bore D2 series NFPA cylinders. Mounting hardware included.	1	0.5		PDF
D2PA-3	NITRA rear pivot eye, steel. For use with 2.5in bore D2 series NFPA cylinders. Mounting hardware included.	1	0.7		PDF
D2PA-4	NITRA rear pivot eye, steel. For use with 3.25in bore D2 series NFPA cylinders. Mounting hardware included.	1	1.3		PDF
D2PA-5	NITRA rear pivot eye, steel. For use with 4in bore D2 series NFPA cylinders. Mounting hardware included.	1	1.4		PDF

D2-Series Heavy Duty Pneumatic Cylinders – Accessories

Flange Attachment



Part no. D2FM-2

D2-Series Heavy Duty Pneumatic Cylinder Accessories						
Part Number	Description	Pcs/Pkg	Wt (lb)	Price	Drawing Link	
D2FM-1	NITRA flange mount plate, steel. For use with 1.5in bore D2 series NFPA cylinders. Mounting hardware included.	1	0.3		PDF	
D2FM-2	NITRA flange mount plate, steel. For use with 2in bore D2 series NFPA cylinders. Mounting hardware included.	1	0.4		PDF	
D2FM-3	NITRA flange mount plate, steel. For use with 2.5in bore D2 series NFPA cylinders. Mounting hardware included.	1	0.5		PDF	
D2FM-4	NITRA flange mount plate, steel. For use with 3.25in bore D2 series NFPA cylinders. Mounting hardware included.	1	3.0		PDF	
D2FM-5	NITRA flange mount plate, steel. For use with 4in bore D2 series NFPA cylinders. Mounting hardware included.	1	4.3		PDF	

Rod Couplers



Part no. D2RCP-2

NITRA self-aligning rod couplers reduce cylinder alignment issues by compensating for $\pm 1^\circ$ angular error and 1/16" lateral misalignment on both the extension and retraction strokes. Better reliability by reducing cylinder and component wear.

D2-Series Heavy Duty Pneumatic Cylinder Accessories						
Part Number	Description	Pcs/Pkg	Wt (lb)	Price	Drawing Link	
D2RCP-1	NITRA self-aligning rod coupler, 7/16-20 UNF thread, steel. For use with D2 series NFPA cylinders.	1	0.5		PDF	
D2RCP-2	NITRA self-aligning rod coupler, 3/4-16 UNF thread, steel. For use with D2 series NFPA cylinders.	1	0.6		PDF	

Jam Nuts



Part no. D2-34-16

D2-Series Heavy Duty Pneumatic Cylinder Accessories						
Part Number	Description	Pcs/Pkg	Wt (lb)	Price	Drawing Link	
D2-716-20	NITRA jam nut, 7/16-20 UNF thread, steel. For use with D2 series NFPA cylinders.	1	0.02		PDF	
D2-34-16	NITRA jam nut, 3/4-16 UNF thread, steel. For use with D2 series NFPA cylinders.	1	0.07		PDF	

D2-Series Heavy Duty Pneumatic Cylinders – Accessories

Mount Brackets



Part no. D2AM-3



Part no. D2BB-3

D2-Series Heavy Duty Pneumatic Cylinder Accessories					
Part Number	Description	Pcs/Pkg	Wt (lb)	Price	Drawing Link
D2AM-1	NITRA angle mount bracket, steel. For use with 1.5in bore D2 series NFPA cylinders. Mounting hardware included.	1	0.5		PDF
D2AM-2	NITRA angle mount bracket, steel. For use with 2in bore D2 series NFPA cylinders. Mounting hardware included.	1	0.9		PDF
D2AM-3	NITRA angle mount bracket, steel. For use with 2.5in bore D2 series NFPA cylinders. Mounting hardware included.	1	0.9		PDF
D2AM-4	NITRA angle mount bracket, steel. For use with 3.25in bore D2 series NFPA cylinders. Mounting hardware included.	1	1.5		PDF
D2AM-5	NITRA angle mount bracket, steel. For use with 4in bore D2 series NFPA cylinders. Mounting hardware included.	1	2.2		PDF
D2BB-1	NITRA base mount bracket, anodized aluminum. For use with 1.5in bore D2 series NFPA cylinders. Mounting hardware included.	1	0.3		PDF
D2BB-2	NITRA base mount bracket, anodized aluminum. For use with 2in bore D2 series NFPA cylinders. Mounting hardware included.	1	0.4		PDF
D2BB-3	NITRA base mount bracket, anodized aluminum. For use with 2.5in bore D2 series NFPA cylinders. Mounting hardware included.	1	0.6		PDF
D2BB-4	NITRA base mount bracket, anodized aluminum. For use with 3.25in bore D2 series NFPA cylinders. Mounting hardware included.	1	1.1		PDF
D2BB-5	NITRA base mount bracket, anodized aluminum. For use with 4in bore D2 series NFPA cylinders. Mounting hardware included.	1	1.2		PDF

Seal Kits



D2-Series Heavy Duty Pneumatic Cylinder Replacement Seal Kit				
Part Number	Description	Pcs/Pkg	Wt (lb)	Price
D2SK-24	NITRA seal kit, for use with 1.5in bore NFPA cylinders. All wear parts for both D-series and D2-series NFPA cylinders included.	1	0.1	
D2SK-32	NITRA seal kit, for use with 2in bore NFPA cylinders. All wear parts for both D-series and D2-series NFPA cylinders included.	1	0.1	
D2SK-40	NITRA seal kit, for use with 2.5in bore NFPA cylinders. All wear parts for both D-series and D2-series NFPA cylinders included.	1	0.1	
D2SK-52	NITRA seal kit, for use with 3.25in bore NFPA cylinders. All wear parts for both D-series and D2-series NFPA cylinders included.	1	0.2	
D2SK-64	NITRA seal kit, for use with 4in bore NFPA cylinders. All wear parts for both D-series and D2-series NFPA cylinders included.	1	0.2	



D2-Series Heavy Duty Pneumatic Cylinders

Nitra Heavy Duty Pneumatic Air Cylinders

The NITRA Pneumatics D2-Series heavy duty cylinders include bore sizes from 1-1/2" to 4" and stroke lengths from 1" to 32" to meet a broad range of applications where abusive conditions exist. These NFPA heavy duty cylinders are constructed with high quality aluminum components and a magnetic piston fitted with a PTFE wear band.

The cylinders feature flush-mount sleeve nuts on the tie rods and are fitted with a PTFE coated cast iron bushing. This bearing ensures smooth rod motion while maintaining rod rigidity and stability.

All D2-Series cylinders have a magnetic piston that can be used along with solid state or reed switches for rod position sensing. The solid state and reed switches sense the rod position by emitting an electrical signal when the magnetized piston reaches a point adjacent to their location. Tie rod mounting allows fast and accurate positioning setup.

Cushioned cylinders are also available to provide end-of-stroke deceleration at both ends. The cushions decelerate the piston rod at the end-of-stroke and are adjustable with a flat head screwdriver.

Mounting Options and Accessories

Front or Rear Flange Mount (MF1 or MF2)

For Front or Rear Flange mounting, use the Flange Mount Kit. Use the drawings below for installation reference.

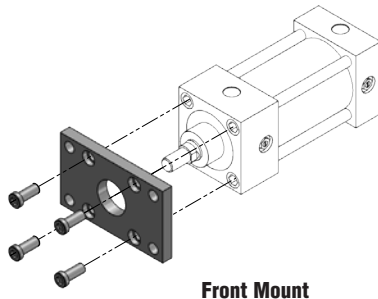

Front Mount

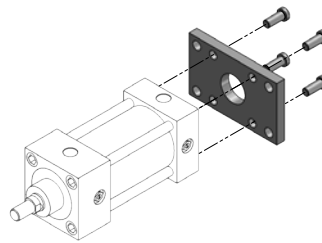

Rear Mount

Rear Clevis Mount (MP1 or MP2)

For Rear Clevis mounting, use the Rear Clevis Mount Kit. Use the drawing below for installation reference.

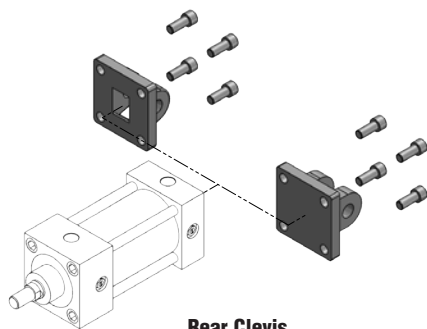

Rear Clevis

Features

- Interchangeable with other popular brands of NFPA cylinders
- Available bore sizes: 1-1/2", 2", 2-1/2", 3-1/4", 4"
- Wide selection of stroke lengths
- All models are double-acting
- Head and end caps drilled for mounting
- All models have a magnetic piston
- PTFE coated cast iron bushing
- 250 psi max operating pressure
- Some models available with adjustable cushions (both ends)
- Made in the USA
- All models are typically available for same-day shipment
- Temperature range is -20° F to 200° F

Operation

Double-acting cylinders have two compressed air ports. One of the ports will extend the rod in the "push" direction and the other port will retract the rod in the "pull" direction.

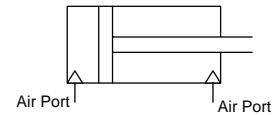

Double-Acting Cylinder
(Force in Push and Pull Direction)



Click on the thumbnail or go to <https://VID-PN-0047> for a short video on NITRA D2 Series Heavy Duty Cylinders.

D2-Series Heavy Duty Pneumatic Cylinders

Base Mount Bracket (Non NFPA)

For base mounting, use the Base Mount Bracket Kit. Use the drawing below for installation reference.

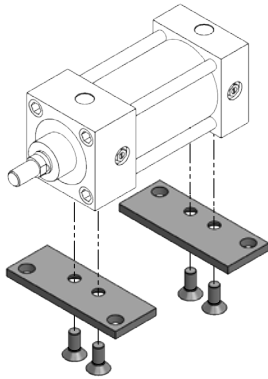

Base Mount

Rear Pivot Mount (MP4)

For Rear Pivot mounting, use the Pivot Attachment Kit. Use the drawing below for installation reference.

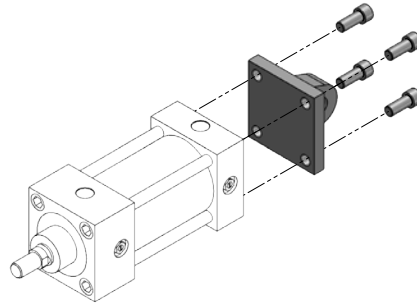

Rear Pivot

Angle Mount Bracket (MS1)

For angle mounting, use the Angle Mount Bracket Kit. Use the drawing below for installation reference.

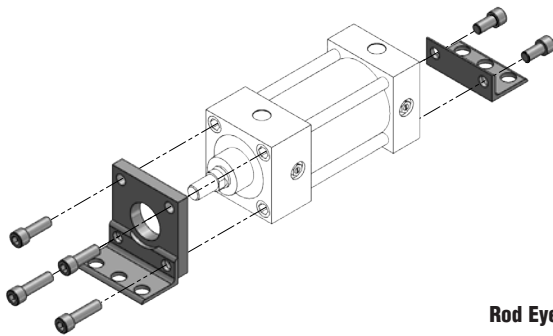

Rod Accessories

There is a Rod Eye, Rod Clevis and Self-Aligning Rod Coupler to fit each size piston rod. 7/16-20 thread size fits 1-1/2", 2" and 2-1/2" bore cylinders. 3/4-16 thread fits 3-1/4" and 4" bore cylinders. Jam nuts are sold separately.

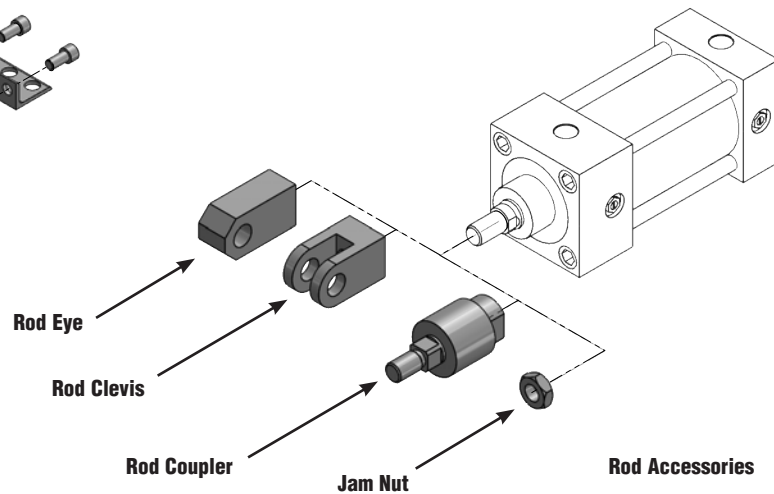

Rod Accessories

D2-Series Heavy Duty Pneumatic Cylinders

Cylinder Features

