



G-Series ISO Pneumatic Cylinders – 100mm Bore

100mm Bore, Double-acting, Magnetic Piston, Cushions



Part no. G100M125MD-MC

NITRA pneumatic ISO 15552 interchangeable cylinder, 100mm bore, 25mm diameter piston rod, G1/2 (BSPP) female ports, double acting; flange, pivot and clevis mount options available. Adjustable cushions on both ends. See the end of the section for accessory details.

Features

- Adjustable cushions
- Internal magnet for sensor switching
- Three sides with longitudinal slots for inserting and securing retractable sensors such as type CPS9F and CPS9Q (see position switches at the end of the cylinder section for further details)
- G (BSPP) threaded ports



100mm bore, double acting, tapped end caps				
Part Number	Price	Stroke Length (mm)	"A" (mm [inch])	Weight (lb)
G100M025MD-MC		25	163 [6.42]	9.3
G100M050MD-MC		50	188 [7.40]	9.8
G100M075MD-MC		75	213 [8.39]	10.3
G100M100MD-MC		100	238 [9.37]	10.8
G100M125MD-MC		125	263 [10.35]	11.4
G100M150MD-MC		150	288 [11.34]	11.9
G100M200MD-MC		200	338 [13.31]	13.0
G100M250MD-MC		250	388 [15.28]	14.0
G100M300MD-MC		300	438 [17.24]	15.0
G100M400MD-MC		400	538 [21.18]	17.1
G100M500MD-MC		500	638 [25.12]	19.2
G100M600MD-MC		600	738 [29.10]	21.3

Specifications	
Aluminum body and end caps	Plastoferrite magnet
C45 chromed piston rod	NBR (Nitrile Butadiene Rubber) buffer + static o-rings
Die cast aluminum head	NBR (Nitrile Butadiene Rubber) cushioning gasket
NBR (Nitrile Butadiene Rubber) piston and piston rod gasket	Brass cushioning needle with needle out movement safety system
Steel guide bushing with bronze and PTFE (Teflon) insert	Pressure rating 145 psi [10 bar], AIR ONLY
Drawn anodized aluminum body	Temperature rating 14°F to 176°F [-10°C to 80°C]
Aluminum piston with PTFE (Teflon) pad	
Extend force at 100 psi = 1217.4 lb.	Retract force at 100 psi = 1141.3 lb.

BSPP = British Standard Pipe Parallel

* The cushions decelerate the piston rod over the last mm (approx.) of stroke and are adjustable. Cushioned cylinders have an adjustable orifice and pre-lubricated nitrile cushion seal.

Mounting Accessories	
Style	Part No.
Foot Mount	GMB-100MM
Front or Rear Flange	GFL-100MM
Male Rear Clevis	GMC-100MM
Spherical Male Clevis	GSMC-100MM

Rod Accessories	
Style	Part No.
Rod Clevis	GRC-M20-15
Rod Eye	GRE-M20-15
Self Aligning Rod Coupler	GRCP-M20-15
Rod Nut	GN-M20-15

Dimensions

mm [inches]

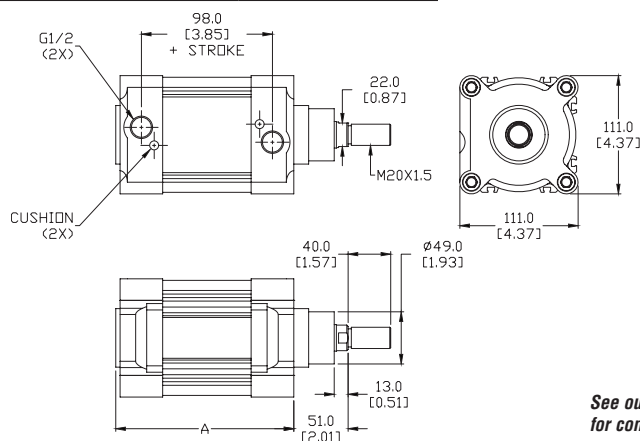

See our website for complete Engineering drawings.



G-Series ISO Pneumatic Cylinders – Accessories

D-Series Heavy Duty Pneumatic Cylinder Accessories				
Part Number	Description	Pcs/Pkg	Wt (lb)	Price
GRC-M10-125	Rod clevis, M10 X 1.25 thread, zinc plated steel. For use with NITRA G-series cylinders.	1	0.2	
GRC-M12-125	Rod clevis, M12 X 1.25 thread, zinc plated steel. For use with NITRA G-series cylinders.	1	0.3	
GRC-M16-15	Rod clevis, M16 X 1.5 thread, zinc plated steel. For use with NITRA G-series cylinders.	1	0.8	
GRC-M20-15	Rod clevis, M20 X 1.5 thread, zinc plated steel. For use with NITRA G-series cylinders.	1	1.5	
GRE-M10-125	Rod eye, M10 X 1.25 thread, spherical bearing, zinc plated steel. For use with NITRA G-series cylinders.	1	0.2	
GRE-M12-125	Rod eye, M12 X 1.25 thread, spherical bearing, zinc plated steel. For use with NITRA G-series cylinders.	1	0.3	
GRE-M16-15	Rod eye, M16 X 1.5 thread, spherical bearing, zinc plated steel. For use with NITRA G-series cylinders.	1	0.5	
GRE-M20-15	Rod eye, M20 X 1.5 thread, spherical bearing, zinc plated steel. For use with NITRA G-series cylinders.	1	0.9	
GRCP-M10-125	Self-aligning rod coupler, M10 X 1.25 thread, zinc plated steel. For use with NITRA G-series cylinders.	1	0.5	
GRCP-M12-125	Self-aligning rod coupler, M12 X 1.25 thread, zinc plated steel. For use with NITRA G-series cylinders.	1	0.7	
GRCP-M16-15	Self-aligning rod coupler, M16 X 1.5 thread, zinc plated steel. For use with NITRA G-series cylinders.	1	1.4	
GRCP-M20-15	Self-aligning rod coupler, M20 X 1.5 thread, zinc plated steel. For use with NITRA G-series cylinders.	1	1.5	
GMB-32MM	Foot mount bracket, zinc plated steel. For use with 32mm bore NITRA G-series cylinders.	1	0.2	
GMB-40MM	Foot mount bracket, zinc plated steel. For use with 40mm bore NITRA G-series cylinders.	1	0.3	
GMB-50MM	Foot mount bracket, zinc plated steel. For use with 50mm bore NITRA G-series cylinders.	1	0.4	
GMB-63MM	Foot mount bracket, zinc plated steel. For use with 63mm bore NITRA G-series cylinders.	1	0.6	
GMB-80MM	Foot mount bracket, zinc plated steel. For use with 80mm bore NITRA G-series cylinders.	1	1.0	
GMB-100MM	Foot mount bracket, zinc plated steel. For use with 100mm bore NITRA G-series cylinders.	1	1.3	
GMC-32MM	Rear pivot eye, zinc plated steel. For use with 32mm bore NITRA G-series cylinders.	1	0.2	
GMC-40MM	Rear pivot eye, zinc plated steel. For use with 40mm bore NITRA G-series cylinders.	1	0.3	
GMC-50MM	Rear pivot eye, zinc plated steel. For use with 50mm bore NITRA G-series cylinders.	1	0.6	
GMC-63MM	Rear pivot eye, zinc plated steel. For use with 63mm bore NITRA G-series cylinders.	1	0.9	
GMC-80MM	Rear pivot eye, zinc plated steel. For use with 80mm bore NITRA G-series cylinders.	1	1.5	
GMC-100MM	Rear pivot eye, zinc plated steel. For use with 100mm bore NITRA G-series cylinders.	1	2.4	
GSMC-32MM	Rear spherical pivot, spherical bearing, zinc plated steel. For use with 32mm bore NITRA G-series cylinders.	1	0.3	
GSMC-40MM	Rear spherical pivot, spherical bearing, zinc plated steel. For use with 40mm bore NITRA G-series cylinders.	1	0.4	
GSMC-50MM	Rear spherical pivot, spherical bearing, zinc plated steel. For use with 50mm bore NITRA G-series cylinders.	1	0.5	
GSMC-63MM	Rear spherical pivot, spherical bearing, zinc plated steel. For use with 63mm bore NITRA G-series cylinders.	1	0.7	
GSMC-80MM	Rear spherical pivot, spherical bearing, zinc plated steel. For use with 80mm bore NITRA G-series cylinders.	1	1.3	
GSMC-100MM	Rear spherical pivot, spherical bearing, zinc plated steel. For use with 100mm bore NITRA G-series cylinders.	1	1.9	
GFL-32MM	Flange mount plate, zinc plated steel. For use with 32mm bore NITRA G-series cylinders.	1	0.5	
GFL-40MM	Flange mount plate, zinc plated steel. For use with 40mm bore NITRA G-series cylinders.	1	0.6	
GFL-50MM	Flange mount plate, zinc plated steel. For use with 50mm bore NITRA G-series cylinders.	1	1.2	
GFL-63MM	Flange mount plate, zinc plated steel. For use with 63mm bore NITRA G-series cylinders.	1	1.5	
GFL-80MM	Flange mount plate, zinc plated steel. For use with 80mm bore NITRA G-series cylinders.	1	3.1	
GFL-100MM	Flange mount plate, zinc plated steel. For use with 100mm bore NITRA G-series cylinders.	1	4.5	
GN-M10-125	Rod nut, M10 X 1.25 thread, zinc plated steel. For use with NITRA G-series cylinders.	1	0.2	
GN-M12-125	Rod nut, M12 X 1.25 thread, zinc plated steel. For use with NITRA G-series cylinders.	1	0.2	
GN-M16-15	Rod nut, M16 X 1.5 thread, zinc plated steel. For use with NITRA G-series cylinders.	1	0.2	
GN-M20-15	Rod nut, M20 X 1.5 thread, zinc plated steel. For use with NITRA G-series cylinders.	1	0.2	

Rod Clevis



Part no. **GRC-M10-125**

Dimensions
mm [inches]

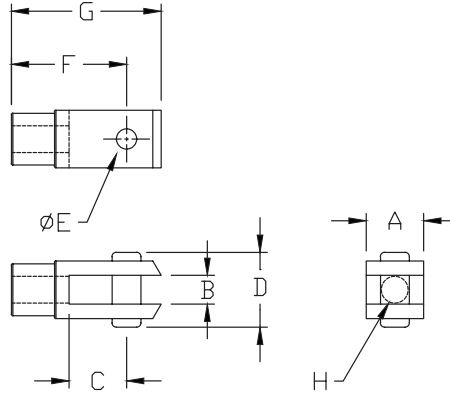

Note: Comes with Pivot Pin installed.

Rod Clevis Dimension Table								
Part #	A	B	C	D	E	F	G	H
GRC-M10-125	20.00 [0.78]	10.00 [0.39]	10.00 [0.39]	26.00 [1.02]	10.00 [0.39]	40.00 [1.57]	52.00 [2.04]	M10x1.25
GRC-M12-125	24.00 [0.94]	12.00 [0.47]	24.00 [0.94]	32.00 [1.25]	12.00 [0.47]	48.00 [1.88]	62.00 [2.44]	M12x1.25
GRC-M16-15	32.00 [1.25]	16.00 [0.62]	32.00 [1.25]	40.00 [1.57]	16.00 [0.62]	64.00 [2.51]	83.00 [3.26]	M16x1.5
GRC-M20-15	40.00 [1.57]	20.00 [0.78]	40.00 [1.57]	48.00 [1.88]	20.00 [0.78]	80.00 [3.14]	105.00 [4.13]	M20x1.5

Rod Eye



Part no. **GRE-M10-125**

Dimensions
mm [inches]

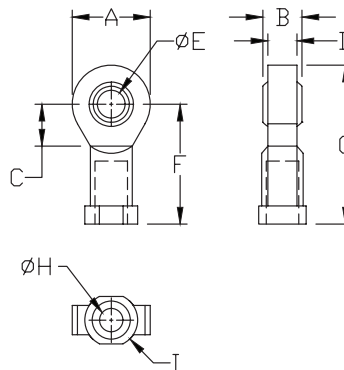

Rod Eye Dimension Table									
Part #	A	B	C	D	E	F	G	H	I
GRE-M10-125	28.00 [1.10]	14.00 [0.55]	15.00 [0.59]	10.50 [0.41]	10.00 [0.39]	43.00 [1.69]	57.00 [2.24]	M10x1.25	19 [0.74]
GRE-M12-125	32.00 [1.25]	16.00 [0.62]	17.00 [0.66]	12.00 [0.47]	12.00 [0.47]	50.00 [1.96]	66.00 [2.59]	M12x1.25	19 [0.74]
GRE-M16-15	42.00 [1.65]	21.00 [0.82]	22.00 [0.86]	15.00 [0.59]	16.00 [0.62]	64.00 [2.51]	85.00 [3.34]	M16x1.5	22 [0.86]
GRE-M20-15	50.00 [1.96]	25.00 [0.98]	26.00 [1.02]	18.00 [0.70]	20.00 [0.78]	77.00 [3.03]	102.00 [4.01]	M20x1.5	27 [1.06]

See our website for complete Engineering drawings.

Self Aligning Rod Coupler



Part no. GRCP-M10-125

Dimensions

mm [inches]

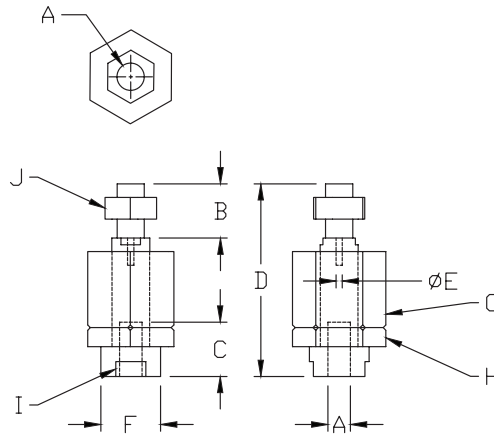

Self Aligning Rod Coupler Dimension Table										
Part #	A	B	C	D	E	F	G	H	I	J
GRCP-M10-125	M10x1.25	20.00 [0.78]	20.00 [0.78]	71.00 [2.79]	4.00 [0.15]	22.00 [0.86]	30.00 [1.18]	30.00 [1.18]	19.00 [0.74]	17.00 [0.66]
GRCP-M12-125	M12x1.25	24.00 [0.94]	20.00 [0.78]	75.00 [2.95]	4.00 [0.15]	22.00 [0.86]	30.00 [1.18]	30.00 [1.18]	19.00 [0.74]	19.00 [0.74]
GRCP-M16-15	M16x1.5	32.00 [1.25]	32.00 [1.25]	103.00 [4.05]	4.00 [0.15]	32.00 [1.25]	41.00 [1.61]	41.00 [1.61]	30.00 [1.18]	24.00 [0.94]
GRCP-M20-15	M20x1.5	40.00 [1.57]	40.00 [1.57]	119.00 [4.68]	4.00 [0.15]	32.00 [1.25]	41.00 [1.61]	41.00 [1.61]	30.00 [1.18]	30.00 [1.18]

Foot Mount Bracket



Part no. GMB-32MM

Dimensions

mm [inches]

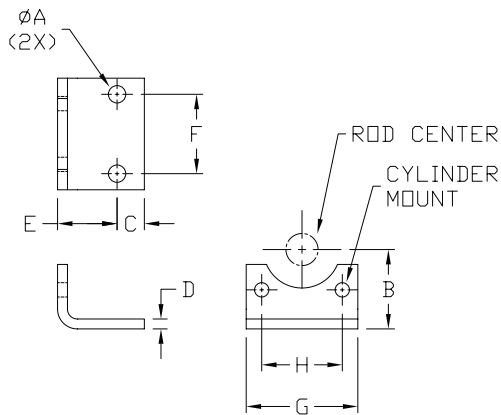

Note: Individually packed with 2 screws

Foot Mount Dimension Table								
Part #	A	B	C	D	E	F	G	H
GMB-32MM	7.00 [0.27]	32.00 [1.25]	11.00 [0.43]	4.00 [0.15]	24.00 [0.94]	32.00 [1.25]	45.00 [1.77]	32.5 [1.28]
GMB-40MM	9.00 [0.35]	36.00 [1.41]	15.00 [0.59]	4.00 [0.15]	28.00 [1.10]	36.00 [1.41]	52.00 [2.04]	38.0 [1.50]
GMB-50MM	9.00 [0.35]	45.00 [1.77]	15.00 [0.59]	4.00 [0.15]	32.00 [1.25]	45.00 [1.77]	52.00 [2.04]	46.5 [1.83]
GMB-63MM	9.00 [0.35]	50.00 [1.96]	15.00 [0.59]	6.00 [0.23]	32.00 [1.25]	50.00 [1.96]	75.00 [2.95]	56.5 [2.22]
GMB-80MM	12.00 [0.47]	63.00 [2.48]	20.00 [0.78]	6.00 [0.23]	41.00 [1.61]	63.00 [2.48]	95.00 [3.74]	63.0 [2.48]
GMB-100MM	14.00 [0.55]	71.00 [2.79]	25.00 [0.98]	6.00 [0.23]	41.00 [1.61]	75.00 [2.95]	115.00 [4.52]	89.0 [3.50]

See our website for complete Engineering drawings.

Rear Pivot Eye



Part no. **GMC-32MM**



Note: Supplied with 4 screws, 4 washers

Dimensions

mm [inches]

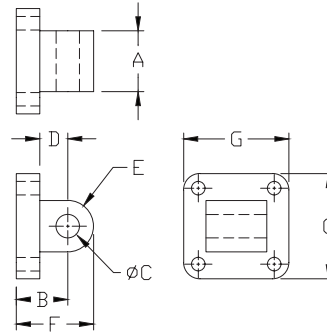

Male Rear Clevis Dimension Table							
Part #	A	B	C	D	E	F	G
GMC-32MM	26.00 [1.02]	22.00 [0.86]	10.00 [0.39]	12.00 [0.47]	11.00 [0.43]	33.00 [1.29]	45.00 [1.77]
GMC-40MM	28.00 [1.10]	25.00 [0.98]	12.00 [0.47]	15.00 [0.59]	13.00 [0.51]	38.00 [1.49]	52.00 [2.04]
GMC-50MM	32.00 [1.25]	27.00 [1.06]	12.00 [0.47]	15.00 [0.59]	13.00 [0.51]	40.00 [1.57]	65.00 [2.55]
GMC-63MM	40.00 [1.57]	32.00 [1.25]	16.00 [0.62]	20.00 [0.78]	17.00 [0.66]	49.00 [1.92]	75.00 [2.95]
GMC-80MM	50.00 [1.96]	36.00 [1.41]	16.00 [0.62]	20.00 [0.78]	17.00 [0.66]	53.00 [2.08]	95.00 [3.74]
GMC-100MM	60.00 [2.36]	41.00 [1.61]	20.00 [0.78]	25.00 [0.98]	21.00 [0.82]	62.00 [2.44]	115.00 [4.52]

Spherical Rear Pivot



Part no. **GSMC-32MM**



Note: Supplied with 4 screws, 4 washers

Dimensions

mm [inches]

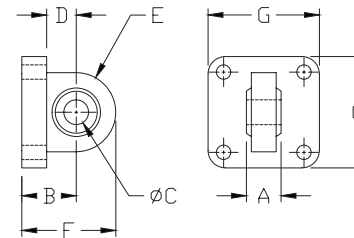

Spherical Male Clevis Dimension Table							
Part #	A	B	C	D	E	F	G
GSMC-32MM	14.00 [0.55]	22.00 [0.86]	10.00 [0.39]	12.00 [0.47]	16.00 [0.62]	38.00 [1.49]	45.00 [1.77]
GSMC-40MM	16.00 [0.62]	25.00 [0.98]	12.00 [0.47]	15.00 [0.59]	19.00 [0.74]	44.00 [1.73]	52.00 [2.04]
GSMC-50MM	16.00 [0.62]	27.00 [1.06]	12.00 [0.47]	15.00 [0.59]	19.00 [0.74]	46.00 [1.81]	65.00 [2.55]
GSMC-63MM	21.00 [0.82]	32.00 [1.25]	16.00 [0.62]	20.00 [0.78]	24.00 [0.94]	56.00 [2.20]	75.00 [2.95]
GSMC-80MM	21.00 [0.82]	36.00 [1.41]	16.00 [0.62]	20.00 [0.78]	24.00 [0.94]	60.00 [2.36]	95.00 [3.74]
GSMC-100MM	25.00 [0.98]	41.00 [1.61]	20.00 [0.78]	25.00 [0.98]	30.00 [1.18]	71.00 [2.79]	115.00 [4.52]

See our website for complete Engineering drawings.

Front or Rear Flange



Part no. GFL-32MM



Note: Supplied with 4 screws

Dimensions
mm [inches]

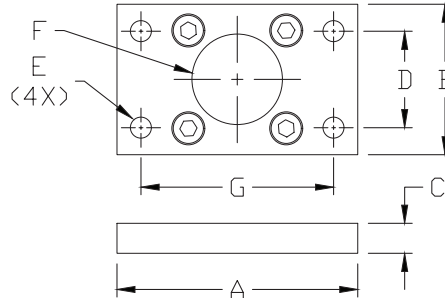

Front or Rear Flange Dimension Table							
Part #	A	B	C	D	E	F	G
GFL-32MM	80.00 [3.14]	50.00 [1.96]	10.00 [0.39]	32.00 [1.25]	7.00 [1.25]	32.00 [1.25]	64.00 [2.52]
GFL-40MM	90.00 [3.54]	55.00 [2.16]	10.00 [0.39]	36.00 [1.41]	9.00 [0.35]	40.00 [1.57]	72.00 [2.83]
GFL-50MM	110.00 [4.33]	65.00 [2.55]	12.00 [0.47]	45.00 [1.77]	9.00 [0.35]	50.00 [1.96]	90.00 [3.54]
GFL-63MM	120.00 [4.72]	75.00 [2.95]	12.00 [0.47]	50.00 [1.96]	9.00 [0.35]	63.00 [2.48]	100.00 [3.93]
GFL-80MM	153.00 [6.02]	95.00 [3.74]	16.00 [0.62]	63.00 [2.48]	12.00 [0.47]	80.00 [3.14]	126.00 [4.96]
GFL-100MM	178.00 [7.00]	115.00 [4.52]	16.00 [0.62]	75.00 [2.95]	14.00 [0.55]	100.00 [3.93]	150.00 [5.90]

Rod Nut



Part no. GN-M20-15

Dimensions
mm [inches]

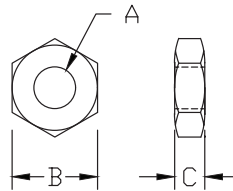

Rod Nut Dimension Table			
Part #	A	B	C
GN-M10-125	M10x1.25	17.00 [0.66]	6.00 [0.23]
GN-M12-125	M12x1.25	19.00 [0.74]	7.00 [0.27]
GN-M16-15	M16x1.5	24.00 [0.94]	8.00 [0.31]
GN-M20-15	M20x1.5	30.00 [1.18]	9.00 [0.35]

See our website for complete Engineering drawings.

Position Switch Cross Reference Chart			
NITRA Switch Type	Cylinder Brand (may fit some of these cylinders)	Photo Example	Groove Illustration
CPS CPSF	NITRA A-Series, D-Series, F-Series		
CPS9C	DE-STA-CO Robohand SMC Compact Air		
CPS9D	Fabco Numatics Rotomation		
CPS9F	NITRA G-Series Fabco Festo Numatics Rotomation		
CPS9H	NITRA E-Series NITRA H-Series		
CPS9M	Norgren		
CPS9Q	NITRA G-Series Parker		
CPS9T	SMC		