

pro^{sense}® Float Level Switches, Vertical Suspendible / Submersible

Float Level Switch Specifications												
Part No.	Price	Float Material	Stem Material	Slosh Shield	Temperature Range*	Pressure	Float Specific Gravity	Electrical Rating ¹	Lead Wires	Mounting	Approvals	Weight (lbs)
FLS-VL-900		Buna-N	Brass	Polybutylene Terephthalate (PBT)	-40°F to 221°F [-40°C to 105°C]	50 psig [3.4 bar]	0.45	SPST-NC, 30W max 240VAC, 0.14 A 120VAC, 0.28 A 120VDC, 0.07 A 24VDC, 0.28 A	22AWG, Halar jacketed 20- foot cable	Suspendible cable	CE (See Approvals table for details)	0.3

* Not for use in hot water at temperatures above 149°F [65°C]

¹ Normally closed switch. Can be converted in the field to function as normally open as described under "Operation". Electrical ratings are for resistive loads ONLY. For inductive loads, maximum life will be obtained with the use of appropriate transient suppression such as an MOV or TVS.

Caution: Not recommended for use with PLC AC inputs or other digital AC input devices due to damage that may occur to the switch or input device.



Dimensions

inches [mm]

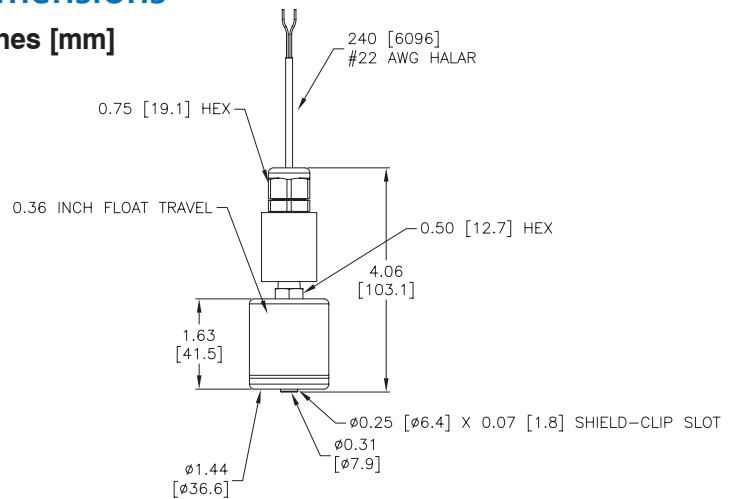

pro^sense® Float Level Switch Kits

Float Level Switch Specifications											
Part No.	Price	Float Material	Other Components Material	Temperature Range	Pressure	Float Specific Gravity	Electrical Rating*	Lead Wires	Mounting Thread	Approvals	Weight (lbs)
FLS-VK-300		316SS	316SS	-40°F to 392°F [-40°C to 200°C]	200 psig [13.79 bar]	0.55	SPST NO or NC, 60W max 240VAC, 0.4 A 120VAC, 0.5 A 120VDC, 0.2 A 24VDC, 0.5 A	22AWG, Teflon 6ft	2in MNPT pipe plug / 1/2 in MNPT conduit	cURus, CE (See Approvals table for details)	4.0

* Each float can be installed to function as either normally open or normally closed switch. Electrical ratings are for resistive loads ONLY. For inductive loads, maximum life will be obtained with the use of appropriate transient suppression such as an MOV or TVS.

Caution: Not recommended for use with PLC AC inputs or other digital AC input devices due to damage that may occur to the switch or input device.

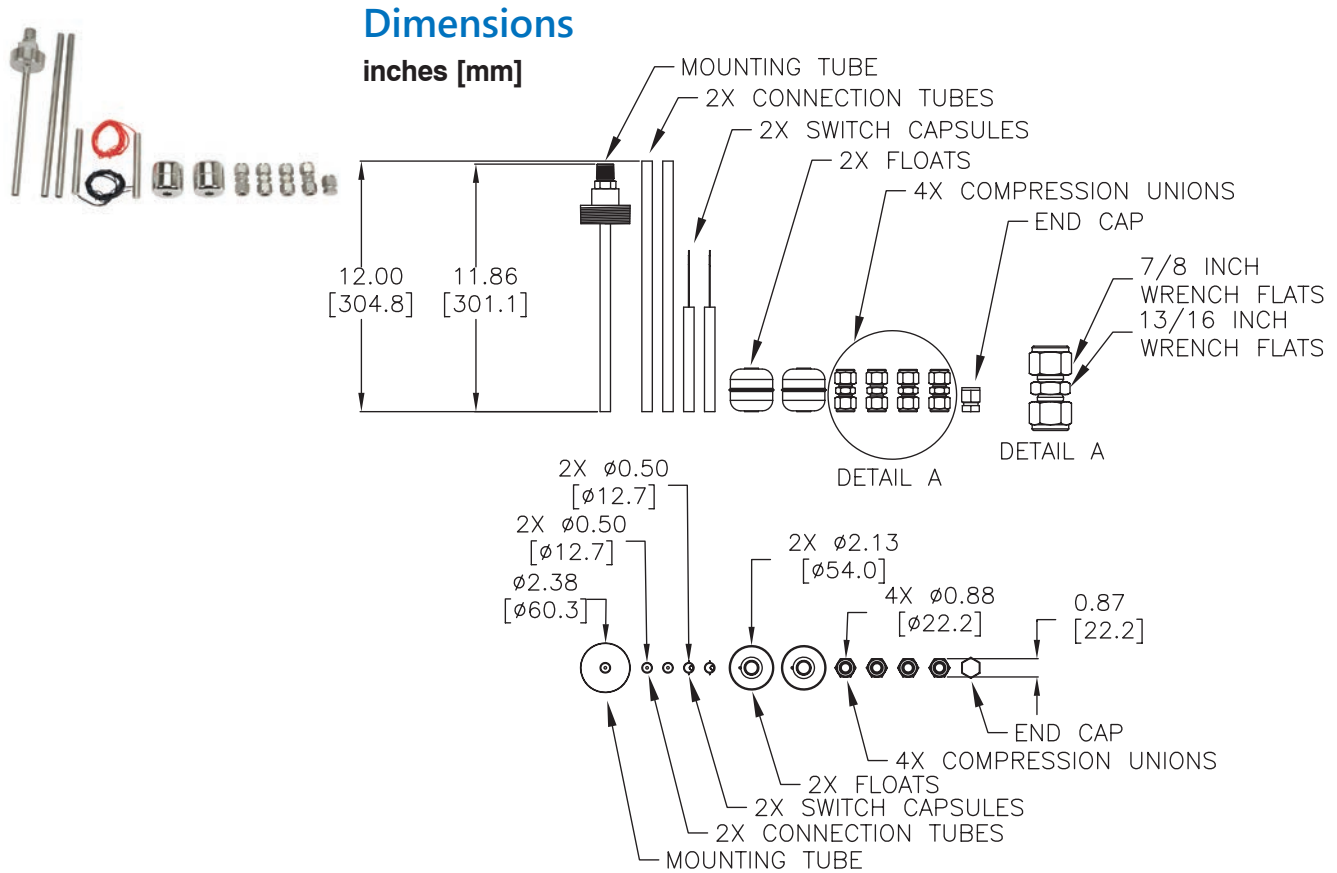

ProSense Float Level Switches

ProSense float level switches provide a low-cost general purpose solution for single point monitoring of liquid level in a variety of applications. Powerful permanent magnets within the float actuate a highly reliable and repeatable hermetically sealed reed switch as the float rises and lowers with liquid level. These switches are available in several different material constructions for compatibility with many types of liquids, a wide temperature range, and system pressure requirements. Vertical and horizontal mounting styles with several mounting thread variations are offered for ease of installation. Reed switches carry electrical ratings for both AC and DC voltage for adaptability to many control interface applications. Although these switches come configured for normally closed operation, most models can be easily converted to normally open operation in the field. Designed to be shock and vibration resistant, ProSense float level switches ensure long and trouble-free service.

Features

- Low-cost solution for general purpose single point liquid level monitoring
- Magnetically operated, highly reliable and repeatable hermetically sealed reed switch
- Vertical and horizontal mounting styles with a variety of mounting threads
- Several material constructions for compatibility with different liquids
- Electrical ratings for AC and DC voltage
- Most switches easily converted in the field from normally closed to normally open operation
- Made in the USA

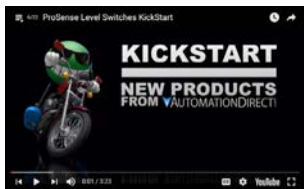

Click on the thumbnail or go to <https://VID-LE-0001> for a short video on ProSense Level Switches.

Operation

ProSense float level switches are shipped configured for normally closed switch operation. Except where noted, most models can be easily converted to normally open operation in the field.

Vertical Mount Switches

For Vertical Mount switches, normally closed is defined as the switch mounted in a vertical position with the mounting threads above the float (top mount) and the float in the "dry" position at the bottom of the stem (Figure 1). When the liquid raises the float, the switch will open.

To change the operation of the switch to normally open, remove the C-clip, remove the float from the stem, flip the float 180 degrees, re-install the float on the stem and replace the C-clip. Now the switch will be normally open in the "dry" position and will close when the liquid raises the float.

Vertical Mount switches can also be mounted with the mounting threads below the float (bottom mount) as in the bottom of a tank. If bottom mounted, switch operation will be the opposite of top mounted installation described above.

Horizontal Mount Switches

For Horizontal Mount switches installed in the side of a tank (side-mounted), normally closed is defined as when the float arm is below and parallel with the stem in the "dry" position (Figure 2). When the liquid raises the float, the switch will open.

To change the operation of the switch, rotate the installed position of the switch 180 degrees so the float arm is above and hanging at an angle with the stem. Now the switch will be normally open in the "dry" position and will close when the liquid raises the float.

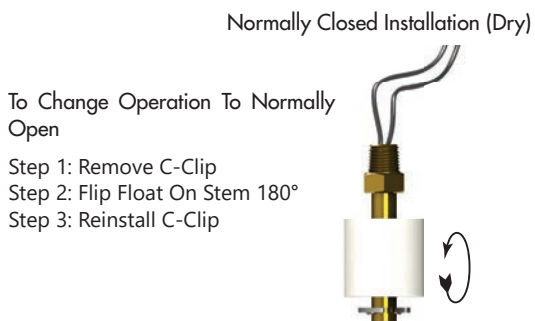

Figure 1: Vertical (Top) Mount Switch Operation

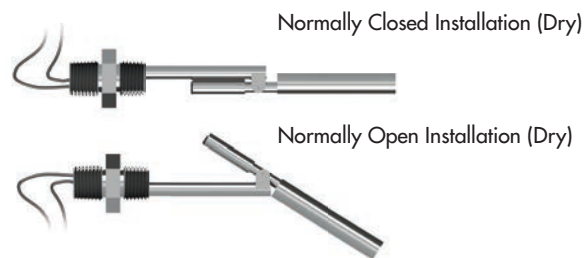

Figure 2: Horizontal Mount Switch Operation