

Dold UG6961 Series Dual Channel Emergency Stop with Adjustable Delay



Designed to protect people and machines in applications with E-stop buttons and safety gates.

• Various delay functions adjustable at device (power off before selecting the desired function):

- Release delay
- Release delay retriggerable
- On delay
- Fleeting on make / break
- Delay function settable via potentiometer

Note: See Delay Functions for more information.



• According to:

- Performance Level (PL) e and category 4 to EN ISO 13849-1: 2008
- SIL Claimed Level (SIL CL) 3 to IEC/EN 62061
- Safety Integrity Level (SIL) 3 to IEC/EN 61508 and IEC/EN 61511
- Acc. to EN 50156-1 for furnaces
- Line fault detection on Push-button:
- Manual restart or automatic restart
- With cross fault monitoring
- 2-channel
- 2 N.O. time delay (selectable) positive guided safety contact(s), 1 N.O. time delay monitoring contact
- LED indicator for operation, delay contacts and failure
- Pluggable terminal blocks for easy exchange of devices

Safety Relays Selection Chart				
Part Number	Price	Marking Type	Voltage	Outputs
UG6961-02PS100-300		Safety relay module	24VDC	2 N.O. time delay (selectable) positive guided safety contact(s), 1 N.O. time delay monitoring contact

Safety Data – Values per EN ISO 13849-1	
Category	4
Performance level	PLe
MTTF _d	215.7 years
DC _{avg}	99%

Function Diagram

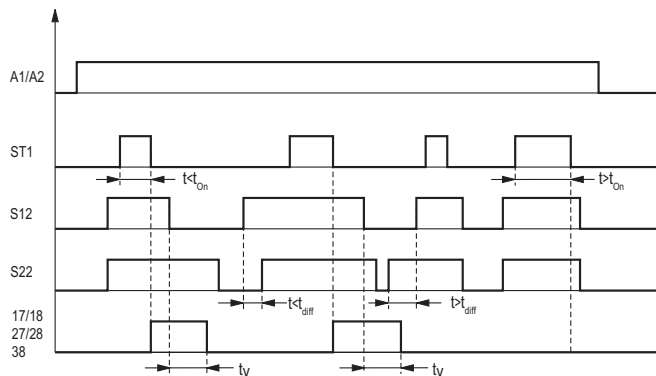

t_{diff} : max. time delay for simultaneity demand dependent on selected safety function
 E-Stop, safety gate, safety mat t_{diff} : max. 3s
 Light curtains t_{diff} : max. 1s
 Two-hand control t_{diff} : max. 0,5s
 other times on request

t_{on} : max. actuation time of start button
 Standard t_{on} : max. 3s
 other times on request

t_v : Time delay
 Example: release delay

Safety Data – Values per IEC/EN 62061 / IEC/EN 61508	
SIL CL	3
SIL	3
HFT (Hardware Failure Tolerance)	1
DC _{avg}	99%
SFF	99.6%
PFH _D	$2.33E^{-10} h^{-1}$

Block Diagram

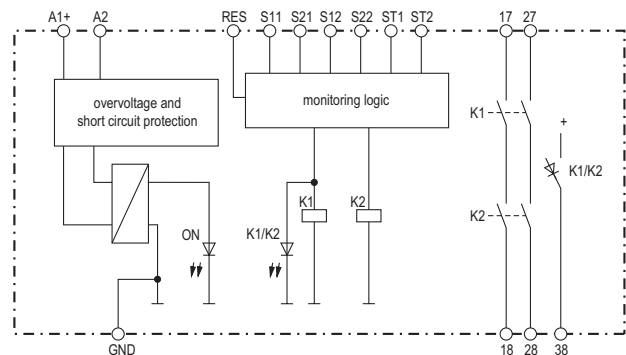

Dold UG6961 Series Dual Channel Emergency Stop with Adjustable Delay

Dold UG6961 Series Dual Channel Emergency Stop with Adjustable Delay Specification Table	
General Specifications	
Temperature	Storage: -25°C to 85°C (-13°F to 185°F) Operating: -15°C to 55°C (5°F to 131°F)
Altitude	<2,000 meters
Vibration Resistance	Amplitude: 0.35mm, Frequency: 10 to 55 Hz (IEC/EN 60-068-2-6)
Degree of Protection	Per IEC/EN 60 529. Housing: IP40; Terminals IP20
Housing	UL 94V-0 Thermoplastic; DIN mount 35 mm x 7.5 mm
Weight	210g (210 oz.)
Agency Approvals and Standards	CSA, cULus file E107778, CE, RoHS, TUV
Terminal Designation per EN 50 005 Wire Connections	1x4 mm ² solid or 1 x 2.5 mm ² stranded ferruled (isolated) or 2 x 1.5 mm ² stranded ferruled (isolated) DIN 46 228-1/-2/-3/-4 or 2 x 2.5 mm ² solid DIN 46 228-1/-2/-3/-4
Wire Fixing	Terminal screws M3.5 box terminals with wire protection.
Wire Connection	60degC/75degC Copper conductors only; AWG20-12 Sol/Str Torque 0.5NM
Input Specifications	
Nominal Voltage	24VDC
Voltage Range	At 10% residual ripple: DC: 0.8 to 1.1 UN;
Maximum Consumption	DC approx. 1.9W
Nominal Frequency	Not applicable
Minimum Off-time	250 ms
Control Voltage on S11 At UN	22VDC
Control Current Typ. Over S12, S22	8mA at UN
Min. Voltage on S12, S22 (relay activated)	10VDC
Short Circuit Protection	Internal with PTC (Positive Temperature Coefficient resistor)
Overvoltage Protection	Internal VDR (Voltage Dependent Resistor)
Output Specifications	
Electrical Contact Life	AC 15 at 5A, 230VAC: > 2.2x10 ⁵ switching cycles
Mechanical Life	> 10x10 ⁶ switching cycles
Contact Type	2 N.O. time delay (selectable) positive guided safety contact(s), 1 N.O. time delay contact
Operate Delay	Manual start: 30ms; automatic start: 350 ms.
Release Delay	E-Stop (1) (6), Safety gate (2) (7), Exclusive or contacts (5): Start up at U : < 65ms Release delay at U and disconnecting the supply: < 40ms Release delay at U and disconnecting S12,S22: < 60ms
Nominal Output Voltage	24VDC: See continuous current limit curve in installation manual.
Thermal Current (I_{tp})	Max. 8A. See continuous current limit curve in installation manual.
Short Circuit Strength	Max. fuse rating: 6A gL (IEC/EN 60 947-5-1)
Switching Capacity (IEC/EN 60 947-5-1)	AC 15: N.O. contacts: 3A/230V DC 13: N.O. contacts: 2A/DC24V
Switching Frequency	Max. 1800 switching cycles/hr
Agency Approvals and Standards	CSA, cULus file E107778, CE, RoHS, TUV

To obtain the most current agency approval information, see the Agency Approval Checklist section on the specific part number's web page at _____

Release Delay: When disconnecting the signal the contacts remain closed and only open after the time is finished. Restarting the unit during time delay has no influence. The time has to run down fully before you can restart the unit.

Release Delay Retriggerable: Same as above, but you can restart the unit while the time is running and before the contacts open.

On Delay: The output contacts are energized after the adjusted time after restarting the unit.

Fleeting on Make: The output contacts are energized after restarting the unit for the adjusted time, and then go off again.

Fleeting on Break: The output contacts are energized for the adjusted time after disconnecting the signal, and then go off again.

Dold UG6961 Series Dual Channel Emergency Stop with Adjustable Delay

Application Examples

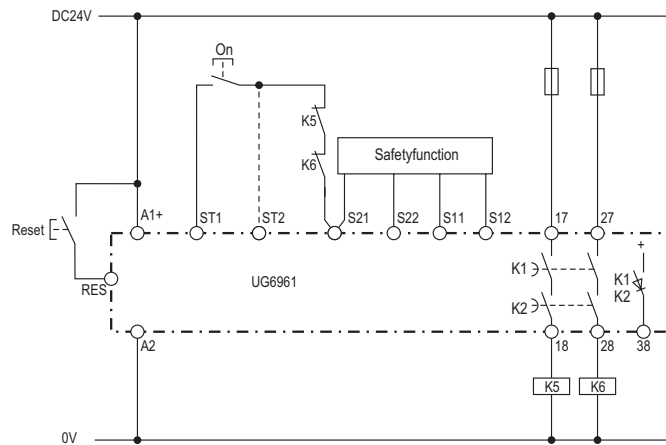

Safety function: see below, Manual-Start (for automatic start make a bridge to ST2 instead of ON button).
 Delay function: release delay (1)



Fct.: E-stop (1),
 with cross fault detection
 3, PL e, Cat. 4

Fct.: Safety gate (2),
 with cross fault detection
 SIL 3, PL e, Cat. 4

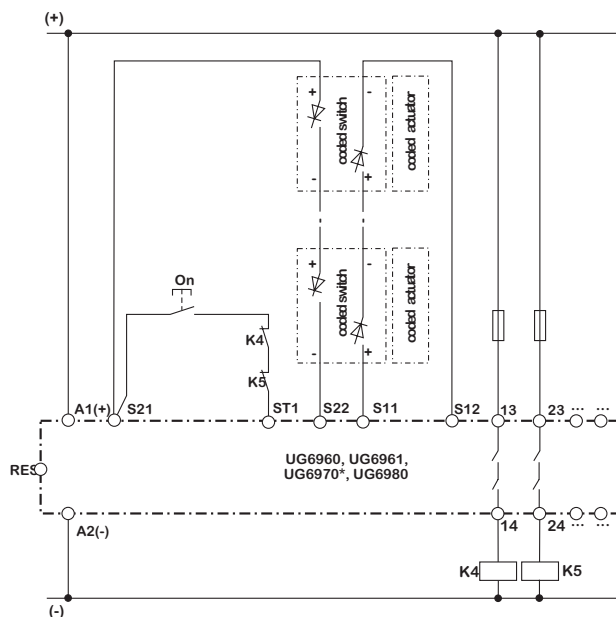

*UG6970: The safety function 2 is connected as well as safety function 1, but
 S11 = S31, S12 = S32, S21 = S41, S22 = S42 and ST1 = ST2

Dold UG6961 Series Dual Channel Emergency Stop with Adjustable Delay

Characteristic Curves

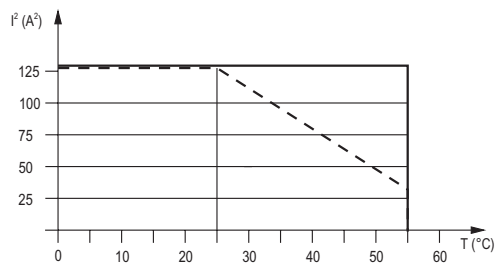

— device free-standing
max. current at 55°C over
2 contact path = $8A \hat{=} 2 \times 8^2 A^2 = 128A^2$

- - - device mounted without distance heated by
devices with same load,
max. current at 55°C over
2 contact path = $4A \hat{=} 2 \times 4^2 A^2 = 32A^2$

$$\Sigma I^2 = I_1^2 + I_2^2$$

I_1, I_2 - current in contact paths

Quadratic total current limit curve

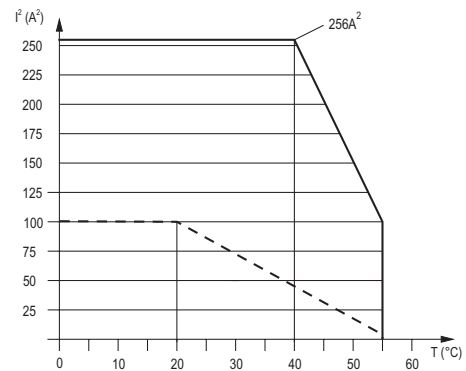

— device free-standing
max. current at 55°C over
4 contact path = $5A \hat{=} 4 \times 5^2 A^2 = 100A^2$

- - - device mounted without distance heated by
devices with same load,
max. current at 55°C over
4 contact path = $1A \hat{=} 4 \times 1^2 A^2 = 4A^2$

$$\Sigma I^2 = I_1^2 + I_2^2 + I_3^2 + I_4^2$$

I_1, I_2, I_3, I_4 - current in contact paths

Quadratic total current limit curve

Dimensions

mm [in]

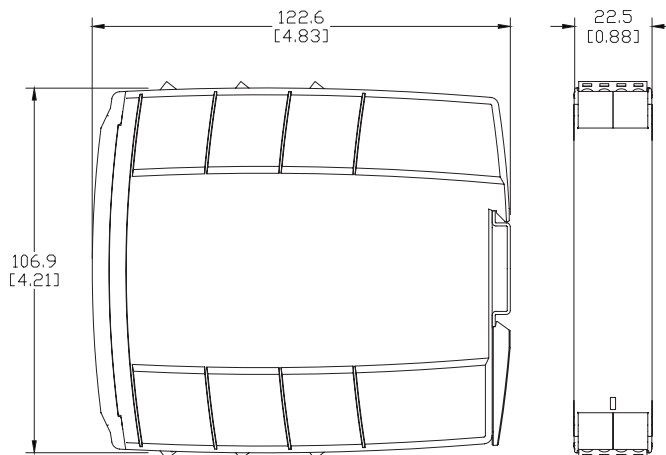

Setting Delay Mode

On the variant /_0_ the delay mode can be set via rotary switch t_{FK1} .
Possible functions:

t_{FK1}	Function
1	Release delay
2	Release delay retriggerable
3	On delay
4	Fleeting on make
5	Fleeting on break

Dold LG5929 Extension Module



Additional contacts for emergency-stop modules and safety gate monitors.

- 1-channel or 2-channel connection
- LED indication for operation
- Output: 5 N.O. and 1 N.C. contacts

Safety Relays Selection Chart				
Part Number	Price	Marking Type	Voltage	Outputs
LG5929-60-100-61		Safety relay extension module	24 VAC/VDC	5 N.O./1 N.C.

Safety Data – Values per EN ISO 13849-1	
Category	4 according to EN 954-1
Performance level	PLe according to EN 13849-1
MTTF_d	>100 years
DC_{avg}	99%
Safety Data – Values per IEC/EN 62061 /IEC/EN 61508	
SIL CL	3 per IEC/EN 62061
SIL	3 per IEC/EN 61508
HFT (Hardware Failure Tolerance)	1
DC_{avg}	99%
SFF	99.7%
PFH_D	4.68E-10 h ⁻¹

Safety Relay Extension Module Specification Table	
General Specifications	
Temperature	Storage: -25°C to 85°C (-13°F to 185°F) Operating: -15°C to 55°C (5°F to 131°F)
Altitude	< 2,000 meters
Vibration Resistance	Amplitude: 0.35mm, Frequency: 10 to 55 Hz (IEC/EN 60-068-2-6)
Degree of Protection	Per IEC/EN 60 529. Housing: IP40; Terminals IP20
Housing	UL 94V-0 Thermoplastic; Din mount 35 mm x 7.5 mm
Weight	205g (7.23 oz.)
Agency Approvals and Standards	CSA, cULus file E107778, CE, RoHS, TUV
Terminal Designation per EN 50 005 Wire Connections	1x4 mm ² solid or 1 x 2.5 mm ² stranded ferruled (isolated) or 2 x 1.5 mm ² stranded ferruled (isolated) DIN 46 228-1/-2/-3/-4 or 2 x 2.5 mm ² solid per DIN 46 228-1/-2/-3 /-4
Wire Fixing	Plus-minus terminal screws M3.5 box terminals with wire protection or cage clamp terminals.
Input Specifications	
Nominal Voltage	24V AC/DC
Voltage Range	AC: 0.85 to 1.1 U _N At 10% residual ripple: 0.9 to 1.1 U _N ; At 48% residual ripple: 0.85 to 1.1 U _N
Maximum Consumption	24VAC/DC: 1.8VA
Nominal Frequency	50 to 60 Hz
Control Current	Control current typ. at 24V over 2 relays: 75 mA
Overvoltage Protection	Internal VDR (Voltage Dependent Resistor)
Output Specifications	
Electrical Contact Life	To AC15 at 2 A,230V: 10 ⁵ switching cycles IEC/EN 60 947-5-1
Mechanical Life	20 x 10 ⁶ switching cycles
Contact Type	5 N.O. positively driven and 1 N.C. relay contacts (N.O. contacts are safety contacts)
Operate/Release Time	Operate typ at U _N : 20 ms.; Release typ at U _N : 35 ms.
Nominal Output Voltage	250VAC
Thermal Current (I_{th})	Max. 5A per contact. See continuous current limit curve in installation manual.
Short Circuit Strength	Max fuse rating:10A gl (IEC/EN 60 9470-5-1); Line circuit breaker: B6A
Switching Capacity IEC/EN 60 947-5-1	AC 15: N.O. contacts: 3A/230V; N.C. contacts: 2A/230VAC DC 13: N.O. contacts: 4A/24V; N.C. contacts: 4A/24VDC; N.O. contact: 8A/24V >25x10 ³ ON: 0.4s, OFF: 9.6s
Switching Frequency	Max. 1,200 switching cycles/hr

Dold LG5929 Extension Module

Wiring

Dimensions mm [in]

LG5929 Block Diagram

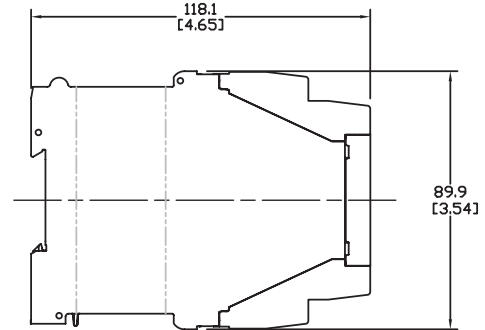
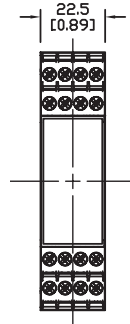
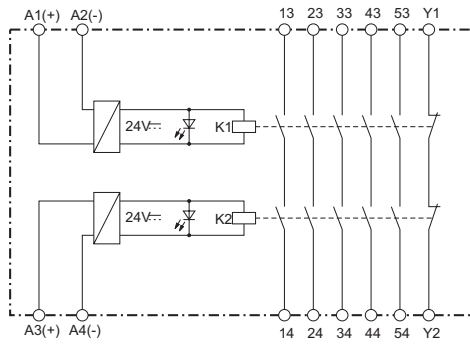

Applications

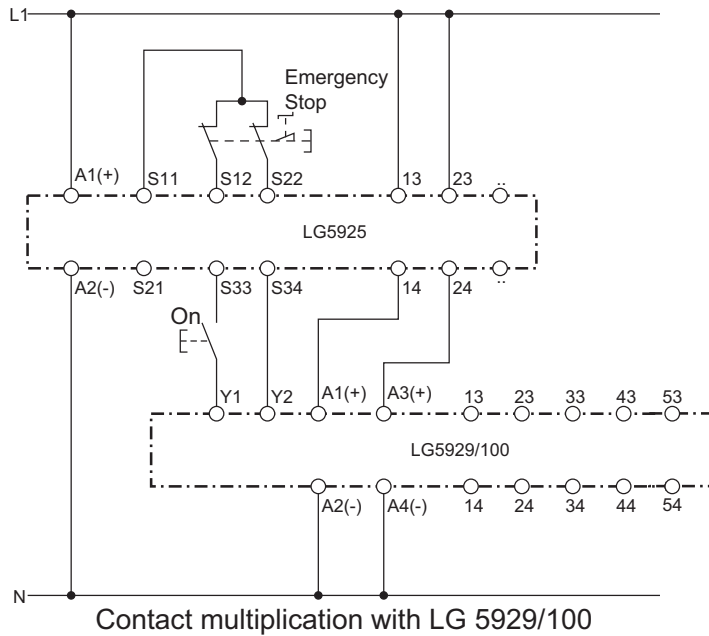

Note: This is a representative drawing. Depending on the LG5925 safety relay you select, different voltage sources may be required.

**Note: When switching inductive loads, surge suppressors are recommended.*

Safety Products



Warning: Safety products sold by AutomationDirect are Safety components only. The purchaser/installer is solely responsible for the application of these components and ensuring all necessary steps have been taken to assure each application and use meets all performance and applicable safety requirements and/or local, national and/or international safety codes as required by the application. AutomationDirect cannot certify that our products, used solely or in conjunction with other AutomationDirect or other vendors' products, will assure safety for any application. Any person using or applying any products sold by AutomationDirect is responsible for learning the safety requirements for their individual application and applying them, and therefore assumes all risks, and accepts full and complete responsibility, for the selection and suitability of the product for their respective application.

AutomationDirect does not provide design or consulting services, and cannot advise whether any specific application or use of our products would ensure compliance with the safety requirements for any application.