

# Dold BH5928 Series – 2-Channel Emergency Stop and Safety Gates with Delay

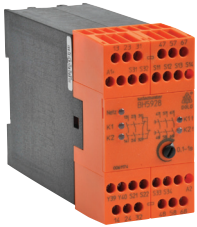

BH5928-92-61-24-1

Designed to protect people and machines in applications with E-stop buttons and safety gates. One or two channels can be monitored with time-delay function.

- Three time-delay options with potentiometer adjustment
- Single and 2-channel operation
- Output: 3 N.O. contacts with delay, 2 N.O. instantaneous contacts, 1 N.C. instantaneous contact
- Line fault detection for ON button, when connected to S33-S34
- Manual restart with button on S33-S34 or automatic restart with jumper between S13-S14
- Can be wired with or without cross-fault monitoring in the E-stop loop
- LED indicators for power and state of operation

Safety Data – Values per EN ISO 13849-1	
<b>Category</b>	4 according to EN 954-1
<b>Performance level</b>	PLe according to EN 13849-1
<b>MTTF<sub>d</sub></b>	>240.5 years
<b>DC<sub>avg</sub></b>	99%
Safety Data – Values per IEC/EN 62061 /IEC/EN 61508	
<b>SIL CL</b>	3 per IEC/EN 62061
<b>SIL</b>	3 per IEC/EN 61508
<b>HFT (Hardware Failure Tolerance)</b>	1
<b>DC<sub>avg</sub></b>	99%
<b>SFF</b>	99.9%
<b>PFH<sub>D</sub></b>	1.94E <sup>-10</sup> h <sup>-1</sup>

Safety Relays					
Part Number	Price	Marking Type	Voltage	Outputs	Time Delay
<a href="#">BH5928-92-61-24-1</a>		2-channel E-STOP / GATE	24 VDC	3 N.O. time delay positive guided safety contacts, 2 N.O. instantaneous positive guided safety contacts and	0.1 to 1 second
<a href="#">BH5928-92-61-24-5</a>		2-channel E-STOP / GATE	24 VDC		0.5 to 5 seconds
<a href="#">BH5928-92-61-24-30</a>		2-channel E-STOP / GATE	24 VDC	1 N.C. instantaneous monitoring contact	3 to 30 seconds

Two-Hand Controllers Safety Relay Specification Table	
<b>General Specifications</b>	
<b>Temperature</b>	Storage: -25°C to 85°C (-13°F to 185°F) Operating: -15°C to 55°C (5°F to 131°F)
<b>Altitude</b>	< 2,000 meters
<b>Vibration Resistance</b>	Amplitude: 0.35mm, Frequency: 10 to 55 Hz (IEC/EN 60-068-2-6)
<b>Degree of Protection</b>	Per IEC/EN 60 529. Housing: IP40; Terminals IP20
<b>Housing</b>	UL 94V-0 Thermoplastic; Din mount 35 mm x 7.5 mm
<b>Weight</b>	400 g (14.11 oz.)
<b>Agency Approvals and Standards</b>	cULus file E107778, CE, RoHS
<b>Terminal Designation per EN 50 005 Wire Connections</b>	1x4 mm <sup>2</sup> solid or 1 x 2.5 mm <sup>2</sup> stranded ferruled (isolated) or 2 x 1.5 mm <sup>2</sup> stranded ferruled (isolated) DIN 46 228-1/-2/-3/-4 or 2 x 2.5 mm <sup>2</sup> stranded ferruled DIN 46 228-1/-2/-3
<b>Wire Fixing</b>	Box terminal with wire protection
<b>Input Specifications</b>	
<b>Nominal Voltage</b>	24VDC
<b>Voltage Range</b>	At 10% residual ripple: DC: 0.9 to 1.1 UN At 48% residual ripple: DC: 0.8 to 1.1 UN
<b>Maximum Consumption</b>	DC approx. 3.5W
<b>Minimum Off-time</b>	1.0 second
<b>Short Circuit Protection</b>	Internal with PTC (Positive Temperature Coefficient resistor)
<b>Overvoltage Protection</b>	Internal VDR (Voltage Dependent Resistor)
<b>Output Specifications</b>	
<b>Electrical Contact Life</b>	To DC 13 at 2A, DC 24V: >1.5 x 10 <sup>5</sup> switching cycles To AC 15 at 2A, 230VAC: 10 <sup>5</sup> switching cycles IEC/EN 60 947-5-1
<b>Mechanical Life</b>	10 x 10 <sup>6</sup> switching cycles
<b>Contact Type</b>	2 N.O. positively driven and 1 N.C. relay contacts, and 3 N.O. positively driven relay contacts with delay. (N.O. contacts are safety contacts)
<b>Operate Delay</b>	Operate delay typ at UN: manual start: 40 ms; automatic start: 500 ms
<b>Release Delay</b>	Release delay typ at UN: Disconnecting supply: 40 ms; Disconnecting S12, S22, S31 and S32: 15ms
<b>Repeat Accuracy</b>	±1% of setting value
<b>Nominal Output Voltage</b>	AC: 250V; DC: See continuous current limit curve in manual.
<b>Thermal Current (I<sub>th</sub>)</b>	Max. 5A, See continuous current limit curve in manual.
<b>Switching of Low Loads</b>	M100 mV; (contacts with 5μ Au) M 1 mA
<b>Short Circuit Strength</b>	Max. fuse rating: 6 A gL (IEC/EN 60 947-5-1); Line circuit breaker C 8 A
<b>Switching Capacity</b>	AC 15: N.O. contacts: 3A/230V; N.C. contacts: 2A/230VAC; DC 13: N.O. contacts: 5A/24VDC; ON: 0.4s, OFF: 9.6 s
<b>Switching Frequency</b>	Max. 1200 switching cycles/hr, with manual restart and short release delay time
<b>Indicator Contact</b>	DC 13: N.C. contact: 2A/24VDC

# Dold BH5928 Series – 2-Channel Emergency Stop and Safety Gates with Delay

## Wiring

BH5928 Block Diagram

## Dimensions

mm [in]

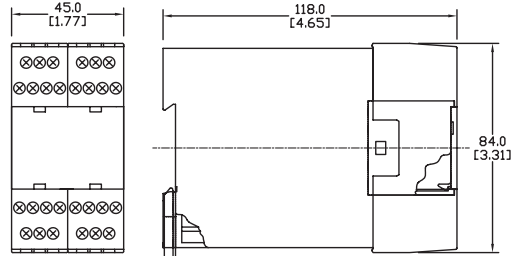
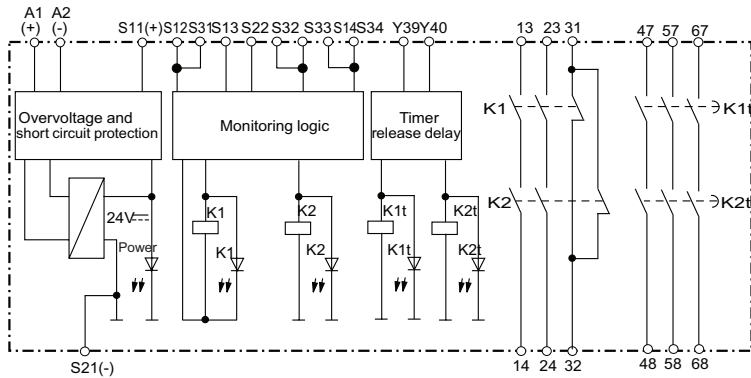

## Applications

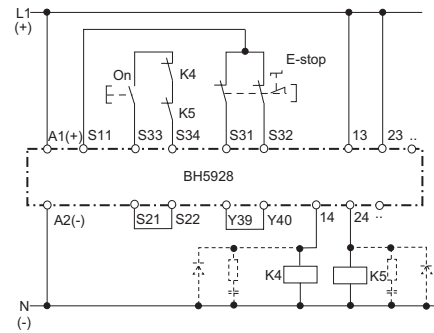
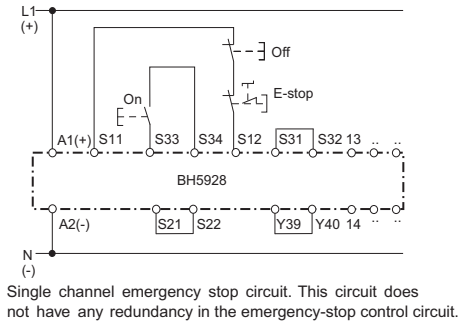

Contact reinforcement by external contactors, 2-channel controlled. The output contacts can be reinforced by external contactors with positive guided contacts for switching currents > 5 A. Functioning of the external contactors is monitored by looping the N.C. contacts into the closing circuit (terminals S13-S14 or S33-S34)

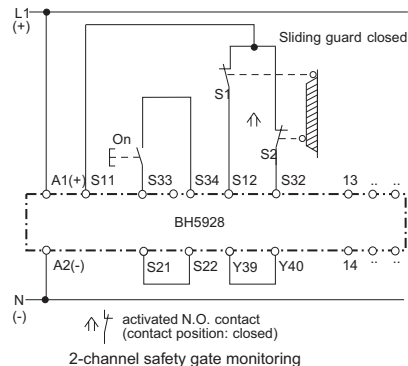
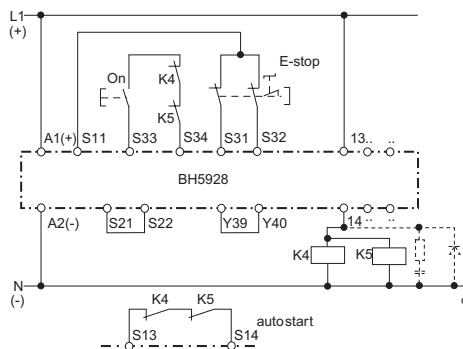
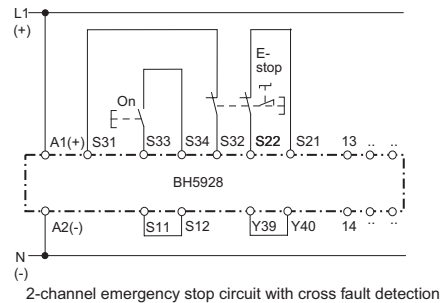
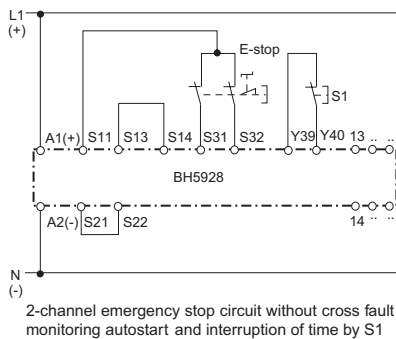

Contact reinforcement by external contactors controlled by one contact path. S33 - S34 must be opened.

\*Note: When switching inductive loads, surge suppressors are recommended.

# Dold LG5929 Extension Module



Additional contacts for emergency-stop modules and safety gate monitors.

- 1-channel or 2-channel connection
- LED indication for operation
- Output: 5 N.O. and 1 N.C. contacts

Safety Relays Selection Chart				
Part Number	Price	Marking Type	Voltage	Outputs
<b>LG5929-60-100-61</b>		Safety relay extension module	24 VAC/VDC	5 N.O./1 N.C.

Safety Data – Values per EN ISO 13849-1	
<b>Category</b>	<b>4 according to EN 954-1</b>
<b>Performance level</b>	PLe according to EN 13849-1
<b>MTTF<sub>d</sub></b>	>100 years
<b>DC<sub>avg</sub></b>	99%
Safety Data – Values per IEC/EN 62061 /IEC/EN 61508	
<b>SIL CL</b>	3 per IEC/EN 62061
<b>SIL</b>	3 per IEC/EN 61508
<b>HFT (Hardware Failure Tolerance)</b>	1
<b>DC<sub>avg</sub></b>	99%
<b>SFF</b>	99.7%
<b>PFH<sub>D</sub></b>	4.68E-10 h <sup>-1</sup>

Safety Relay Extension Module Specification Table	
<b>General Specifications</b>	
<b>Temperature</b>	Storage: -25°C to 85°C (-13°F to 185°F) Operating: -15°C to 55°C (5°F to 131°F)
<b>Altitude</b>	< 2,000 meters
<b>Vibration Resistance</b>	Amplitude: 0.35mm, Frequency: 10 to 55 Hz (IEC/EN 60-068-2-6)
<b>Degree of Protection</b>	Per IEC/EN 60 529. Housing: IP40; Terminals IP20
<b>Housing</b>	UL 94V-0 Thermoplastic; Din mount 35 mm x 7.5 mm
<b>Weight</b>	205g (7.23 oz.)
<b>Agency Approvals and Standards</b>	CSA, cULus file E107778, CE, RoHS, TUV
<b>Terminal Designation per EN 50 005 Wire Connections</b>	1x4 mm <sup>2</sup> solid or 1 x 2.5 mm <sup>2</sup> stranded ferruled (isolated) or 2 x 1.5 mm <sup>2</sup> stranded ferruled (isolated) DIN 46 228-1/-2/-3/-4 or 2 x 2.5 mm <sup>2</sup> solid per DIN 46 228-1/-2/-3 /-4
<b>Wire Fixing</b>	Plus-minus terminal screws M3.5 box terminals with wire protection or cage clamp terminals.
<b>Input Specifications</b>	
<b>Nominal Voltage</b>	24V AC/DC
<b>Voltage Range</b>	AC: 0.85 to 1.1 U <sub>N</sub> At 10% residual ripple: 0.9 to 1.1 U <sub>N</sub> ; At 48% residual ripple: 0.85 to 1.1 U <sub>N</sub>
<b>Maximum Consumption</b>	24VAC/DC: 1.8VA
<b>Nominal Frequency</b>	50 to 60 Hz
<b>Control Current</b>	Control current typ. at 24V over 2 relays: 75 mA
<b>Overvoltage Protection</b>	Internal VDR (Voltage Dependent Resistor)
<b>Output Specifications</b>	
<b>Electrical Contact Life</b>	To AC15 at 2 A,230V: 10 <sup>5</sup> switching cycles IEC/EN 60 947-5-1
<b>Mechanical Life</b>	20 x 10 <sup>6</sup> switching cycles
<b>Contact Type</b>	5 N.O. positively driven and 1 N.C. relay contacts (N.O. contacts are safety contacts)
<b>Operate/Release Time</b>	Operate typ at U <sub>N</sub> : 20 ms.; Release typ at U <sub>N</sub> : 35 ms.
<b>Nominal Output Voltage</b>	250VAC
<b>Thermal Current (I<sub>th</sub>)</b>	Max. 5A per contact. See continuous current limit curve in installation manual.
<b>Short Circuit Strength</b>	Max fuse rating:10A gl (IEC/EN 60 9470-5-1); Line circuit breaker: B6A
<b>Switching Capacity IEC/EN 60 947-5-1</b>	AC 15: N.O. contacts: 3A/230V; N.C. contacts: 2A/230VAC DC 13: N.O. contacts: 4A/24V; N.C. contacts: 4A/24VDC; N.O. contact: 8A/24V >25x10 <sup>3</sup> ON: 0.4s, OFF: 9.6s
<b>Switching Frequency</b>	Max. 1,200 switching cycles/hr

# Dold LG5929 Extension Module

## Wiring

## Dimensions mm [in]

**LG5929 Block Diagram**

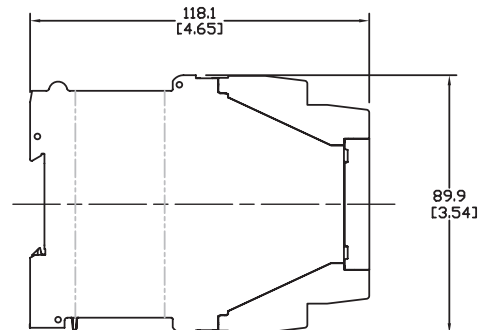
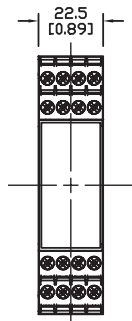
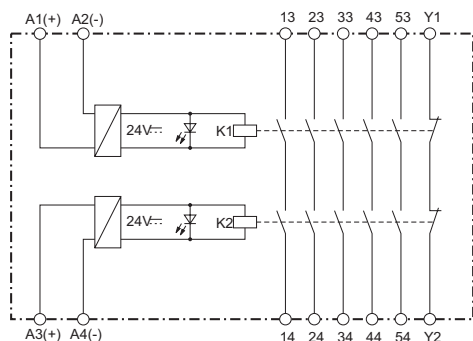

## Applications

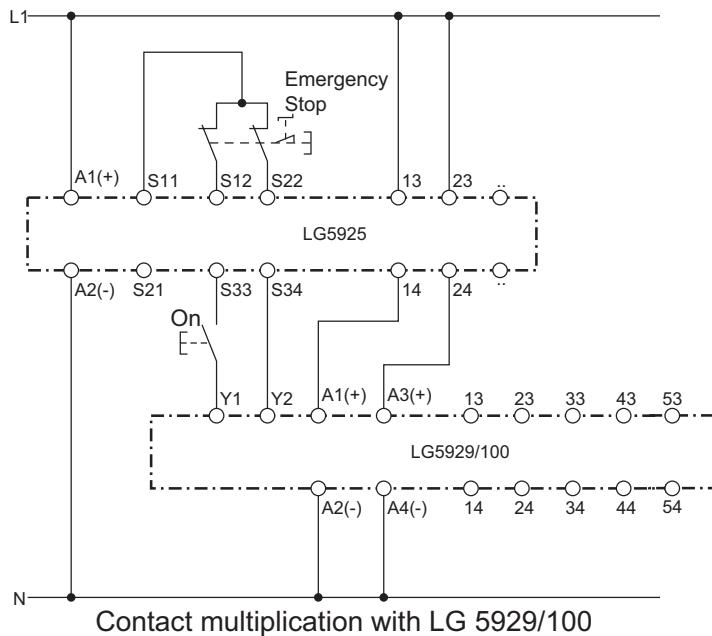

*Note: This is a representative drawing. Depending on the LG5925 safety relay you select, different voltage sources may be required.*

*\*Note: When switching inductive loads, surge suppressors are recommended.*

# Safety Products



*Warning: Safety products sold by AutomationDirect are Safety components only. The purchaser/installer is solely responsible for the application of these components and ensuring all necessary steps have been taken to assure each application and use meets all performance and applicable safety requirements and/or local, national and/or international safety codes as required by the application. AutomationDirect cannot certify that our products, used solely or in conjunction with other AutomationDirect or other vendors' products, will assure safety for any application. Any person using or applying any products sold by AutomationDirect is responsible for learning the safety requirements for their individual application and applying them, and therefore assumes all risks, and accepts full and complete responsibility, for the selection and suitability of the product for their respective application.*

*AutomationDirect does not provide design or consulting services, and cannot advise whether any specific application or use of our products would ensure compliance with the safety requirements for any application.*