

Dold Safety Relay Mat and Edge

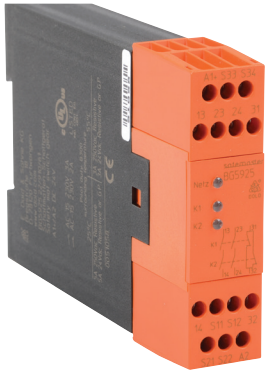

- Safety-mat switch gear with manual or automatic restart
- Can also be used for safety edges
- Output: 2 NO contacts
- Line fault detection at the ON pushbutton
- LED indicator for state of operation
- LED indicator for channel 1 and 2
- Wire connection: also 2 x 1.5 mm² stranded ferruled (isolated), DIN 46 228-1/-2/-3/-4 or 2 x 2.5 mm² stranded



Safety Data – Values per EN ISO 13849-1

Category	4
Performance level	PLe
MTTF_d	236.3 years
DC_{avg}	99%

Safety Data – Values per IEC/EN 62061 /IEC/EN 61508

SIL CL	3
SIL	3
HFT (Hardware Failure Tolerance)	1
DC_{avg}	99%
SFF	99.7%
PFH_D	2.09E ⁻¹⁰ h ⁻¹

Safety Relays Selection Chart

Part Number	Price	Marking Type	Voltage	Outputs
BG5925-22-910-24		Dold safety relay module, safety mat/edges, dual channel, manual or automatic restart	24VDC coil voltage	2 NO positive guided safety contact(s), 1 NC monitoring contact(s)

Relay Mat and Edge Specification Table

General Specifications	
Temperature	Storage: -25°C to 85°C (-13°F to 185°F) Operating: -15°C to 55°C (5°F to 131°F)
Altitude	< 2000m (6562ft)
Vibration Resistance	Amplitude: 0.35mm, Frequency: 10 to 55 Hz (IEC/EN 60-068-2-6)
Degree of Protection	Per IEC/EN 60 529. Housing: IP40; Terminals IP20
Housing	UL 94V-0 Thermoplastic; DIN mount 35 mm x 7.5 mm
Weight	220g (7.76 oz.)
Terminal Designation per EN 50 005 Wire Connections	1x4 mm ² solid or 1x2.5 mm ² stranded ferruled (isolated) or 2x1.5 mm ² stranded ferruled (isolated) DIN 46 228-1/-2/-3/-4 or 2 x 2.5 mm ² stranded ferruled DIN 46 228-1/-2/-3
Wire Fixing	Box terminal with wire protection, removable terminal strips
Wire Connection	60°C/75°C Copper conductors only AWG20-12 Sol Torque 0.8N•m (0.59 lb•ft) AWG 20-14 STR Torque 0.8 NM(0.59 lb•ft)
Input Specifications	
Nominal Voltage	24VDC
Voltage Range	At 10% residual ripple: 0.9 to 1.1 UN
Maximum Consumption	DC approx. 2W
Control Voltage - S11	UN: 23VDC
Control Current on S12, S22	40mA at UN
Minimum Voltage on Terminals S12, S22 (when relay activated)	21VDC
Short Circuit Protection	Internal fuse rating
Overvoltage Protection	Internal VDR (Voltage Dependent Resistor)
Output Specifications	
Electrical Contact Life	To 2A, AC 230V: > 10 ⁵ switching cycles IEC/EN 60 947-5-1
Mechanical Life	10 x 10 ⁶ switching cycles
Contact Type	Forcibly guided
Operate Delay	Operate delay typ at UN: manual start 80ms; automatic start 170ms
Release Delay	Release delay typ. at UN: Disconnecting the supply: 50ms; Disconnecting S12, S22: 15ms
Nominal Output Voltage	AC: 250V; DC: See continuous current limit curve in installation manual.
Thermal Current (I_{th})	Max. 5A per contact. See continuous current limit curve in installation manual.
Switching of Low Loads	M100mV; (contacts with 5µ Au) M 1mA
Short Circuit Strength	Max fuse rating: 6A gl (IEC/EN 60 947-5-1); Line circuit breaker: C 8A
Switching Capacity	AC 15: NO contacts: 3A/230V; NC contacts: 2A/230V AC DC 13: NO contacts: 1A/24V DC, 0.5A/110V AC; NO contacts: 1A/24V DC
Switching Frequency	Max. 1200 switching cycles/hr
Agency Approvals	cULus file E107778, CE, RoHS, TUV

To obtain the most current agency approval information, see the Agency Approval Checklist section on the specific part number's web page at _____

Dold Safety Relay Mat and Edge

Function Diagram

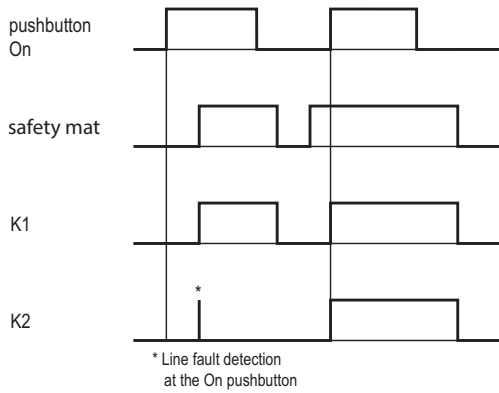

Block Diagram

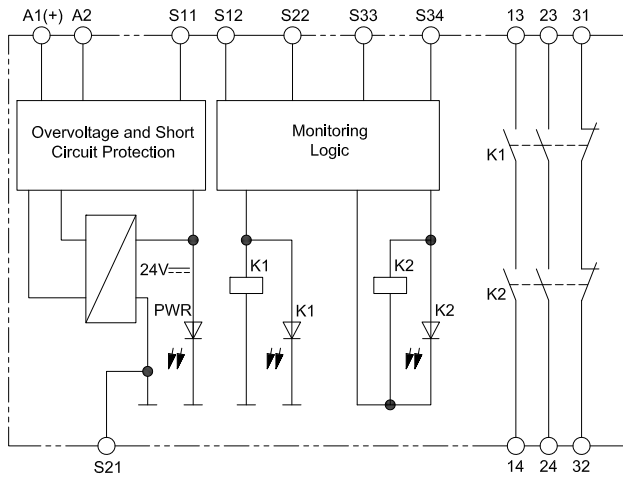

Dimensions

mm [in]

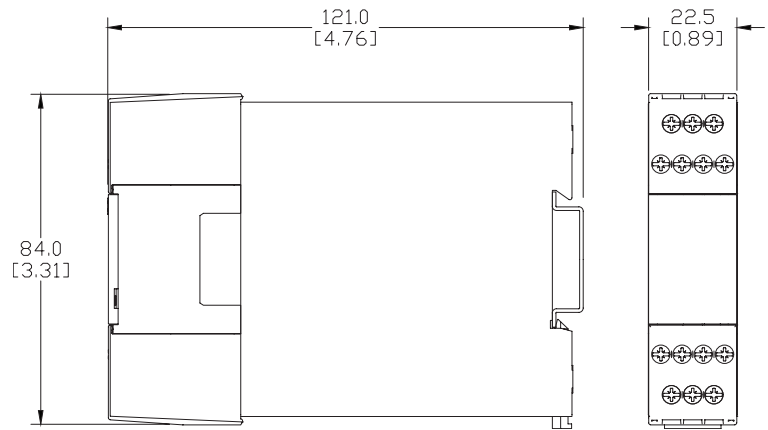

Characteristic Curves

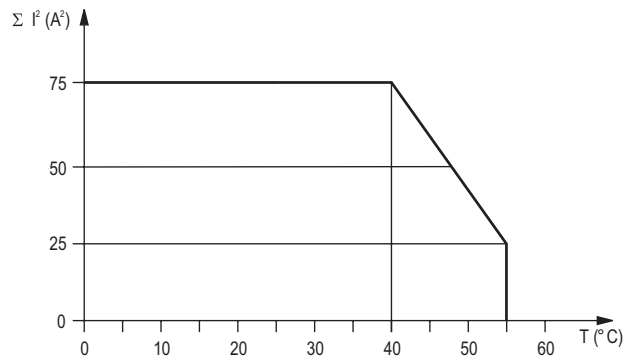
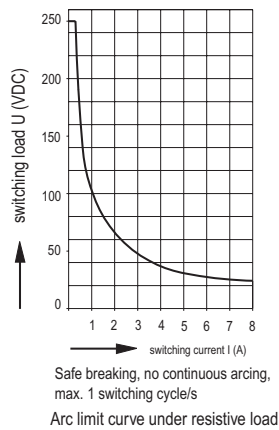

Quadratic total current

$$\Sigma I^2 = I_1^2 + I_2^2 + I_3^2$$

I_1, I_2, I_3 - current in contact paths

Quadratic total current limit curve

Dold Safety Relay Mat and Edge

Application Examples

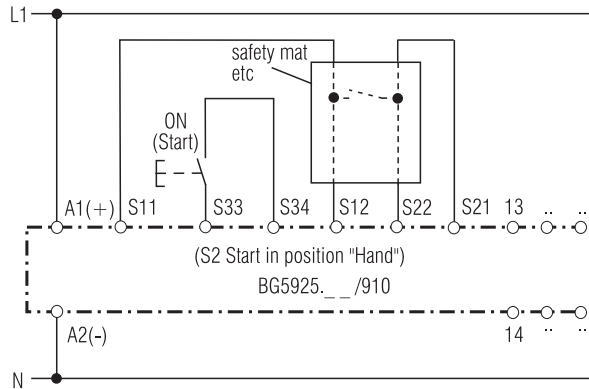

Switch gear for safety mats and edges
switch S2 position: Manual start
(For automatic restart S2 in position Autostart and link on S33-S34)
Suited up to SIL3, Performance Level e, Cat. 4

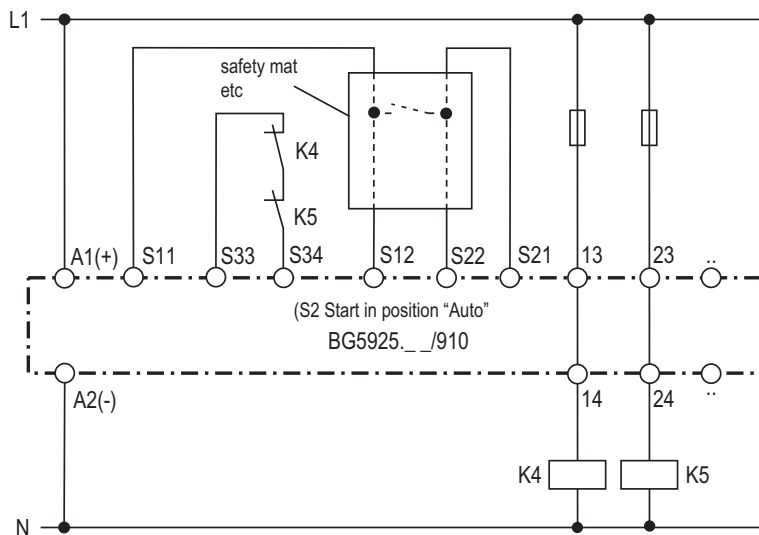

Switch gear for safety mats and edges
Contact reinforcement by external contactors, 2-channel.
switch S2 position: Auto start
Suited up to SIL3, Performance Level e, Cat. 4

Dold LG5929 Extension Module



Additional contacts for emergency-stop modules and safety gate monitors.

- 1-channel or 2-channel connection
- LED indication for operation
- Output: 5 N.O. and 1 N.C. contacts

Safety Relays Selection Chart				
Part Number	Price	Marking Type	Voltage	Outputs
LG5929-60-100-61		Safety relay extension module	24 VAC/VDC	5 N.O./1 N.C.

Safety Data – Values per EN ISO 13849-1	
Category	4 according to EN 954-1
Performance level	PLe according to EN 13849-1
MTTF_d	>100 years
DC_{avg}	99%
Safety Data – Values per IEC/EN 62061 /IEC/EN 61508	
SIL CL	3 per IEC/EN 62061
SIL	3 per IEC/EN 61508
HFT (Hardware Failure Tolerance)	1
DC_{avg}	99%
SFF	99.7%
PFH_D	4.68E-10 h ⁻¹

Safety Relay Extension Module Specification Table	
General Specifications	
Temperature	Storage: -25°C to 85°C (-13°F to 185°F) Operating: -15°C to 55°C (5°F to 131°F)
Altitude	< 2,000 meters
Vibration Resistance	Amplitude: 0.35mm, Frequency: 10 to 55 Hz (IEC/EN 60-068-2-6)
Degree of Protection	Per IEC/EN 60 529. Housing: IP40; Terminals IP20
Housing	UL 94V-0 Thermoplastic; Din mount 35 mm x 7.5 mm
Weight	205g (7.23 oz.)
Agency Approvals and Standards	CSA, cULus file E107778, CE, RoHS, TUV
Terminal Designation per EN 50 005 Wire Connections	1x4 mm ² solid or 1 x 2.5 mm ² stranded ferruled (isolated) or 2 x 1.5 mm ² stranded ferruled (isolated) DIN 46 228-1/-2/-3/-4 or 2 x 2.5 mm ² solid per DIN 46 228-1/-2/-3 /-4
Wire Fixing	Plus-minus terminal screws M3.5 box terminals with wire protection or cage clamp terminals.
Input Specifications	
Nominal Voltage	24V AC/DC
Voltage Range	AC: 0.85 to 1.1 U _N At 10% residual ripple: 0.9 to 1.1 U _N ; At 48% residual ripple: 0.85 to 1.1 U _N
Maximum Consumption	24VAC/DC: 1.8VA
Nominal Frequency	50 to 60 Hz
Control Current	Control current typ. at 24V over 2 relays: 75 mA
Overvoltage Protection	Internal VDR (Voltage Dependent Resistor)
Output Specifications	
Electrical Contact Life	To AC15 at 2 A,230V: 10 ⁵ switching cycles IEC/EN 60 947-5-1
Mechanical Life	20 x 10 ⁶ switching cycles
Contact Type	5 N.O. positively driven and 1 N.C. relay contacts (N.O. contacts are safety contacts)
Operate/Release Time	Operate typ at U _N : 20 ms.; Release typ at U _N : 35 ms.
Nominal Output Voltage	250VAC
Thermal Current (I_{th})	Max. 5A per contact. See continuous current limit curve in installation manual.
Short Circuit Strength	Max fuse rating:10A gl (IEC/EN 60 9470-5-1); Line circuit breaker: B6A
Switching Capacity IEC/EN 60 947-5-1	AC 15: N.O. contacts: 3A/230V; N.C. contacts: 2A/230VAC DC 13: N.O. contacts: 4A/24V; N.C. contacts: 4A/24VDC; N.O. contact: 8A/24V >25x10 ³ ON: 0.4s, OFF: 9.6s
Switching Frequency	Max. 1,200 switching cycles/hr

Dold LG5929 Extension Module

Wiring

Dimensions mm [in]

LG5929 Block Diagram

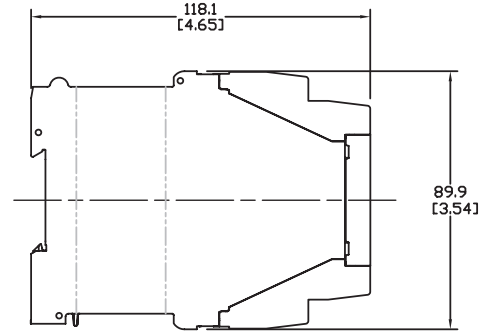
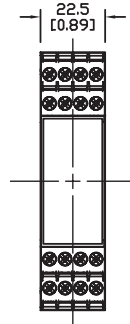
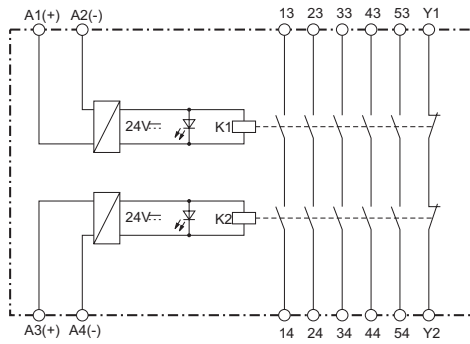

Applications

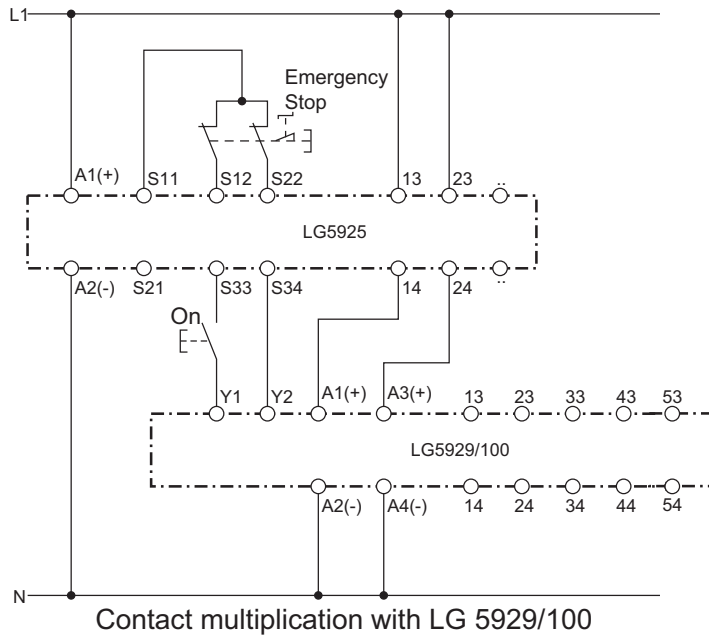

Note: This is a representative drawing. Depending on the LG5925 safety relay you select, different voltage sources may be required.

**Note: When switching inductive loads, surge suppressors are recommended.*

Safety Products



Warning: Safety products sold by AutomationDirect are Safety components only. The purchaser/installer is solely responsible for the application of these components and ensuring all necessary steps have been taken to assure each application and use meets all performance and applicable safety requirements and/or local, national and/or international safety codes as required by the application. AutomationDirect cannot certify that our products, used solely or in conjunction with other AutomationDirect or other vendors' products, will assure safety for any application. Any person using or applying any products sold by AutomationDirect is responsible for learning the safety requirements for their individual application and applying them, and therefore assumes all risks, and accepts full and complete responsibility, for the selection and suitability of the product for their respective application.

AutomationDirect does not provide design or consulting services, and cannot advise whether any specific application or use of our products would ensure compliance with the safety requirements for any application.