

Dold UG6970 Series Safety Relay 2 With Independent Selectable Function



- Designed to protect people and machines in applications with various safety devices.
- Two independent, separately adjustable safety functions: (power off before selecting the desired function):
 - E-Stop
 - Safety gate
 - Two-hand control
 - Safety mat / Safety edge
 - Exclusive XOR contacts
 - Light curtain
- Only one device, two safety functions at the same time

- According to:
 - Performance Level (PL) e and category 4 to EN ISO 13849-1: 2008
 - SIL Claimed Level (SIL CL) 3 to IEC/EN 62061
 - Safety Integrity Level (SIL) 3 to IEC/EN 61508 and IEC/EN 61511
 - Acc. to EN 50156-1 for furnaces
- Line fault detection on Pushbutton:
- Manual restart or automatic restart
- With or without cross fault monitoring
- 2-channel
- Forcibly guided output contacts
- Output: 2 N.O. contacts per safety function
- One semiconductor output per safety function
- LED indicator for operation, safety function 1, 2 and failure
- Pluggable terminal blocks for easy exchange of devices
- Width: 22.5 mm
- Two PNP sensor inputs only

Safety Data – Values per EN ISO 13849-1	
Category	4
Performance level	PLe
MTTF _d	134.5 years
DC _{avg}	99%
Safety Data – Values per IEC/EN 62061 /IEC/EN 61508	
SIL CL	3
SIL	3
HFT (Hardware Failure Tolerance)	1
DC _{avg}	99%
SFF	99.6%
PFH _D	3.89E-10 h ⁻¹

Safety Relays Selection Chart				
Part Number	Price	Marking Type	Voltage	Outputs
UG6970-04PS-61-24		Safety relay module	24VDC	4 N.O. positive guided safety contact(s), 2 N.O. monitoring contact(s)

Function Diagram

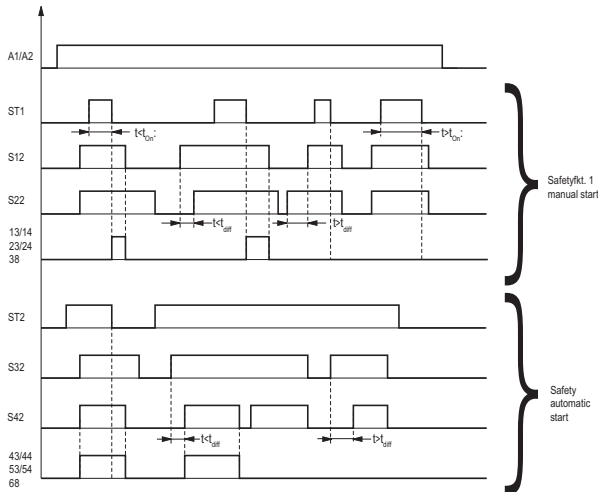

t_{off} : max. time delay for simultaneity demand dependent on selected safety function
 E-Stop, safety gate, safety mat t_{off} : max. 3s
 Light curtains t_{off} : max. 1s
 Two-hand control t_{off} : max. 0,5s
 other times on request

t_{on} : max. actuation time of start button
 Standard t_{on} : max. 3s
 other times on request

Block Diagram

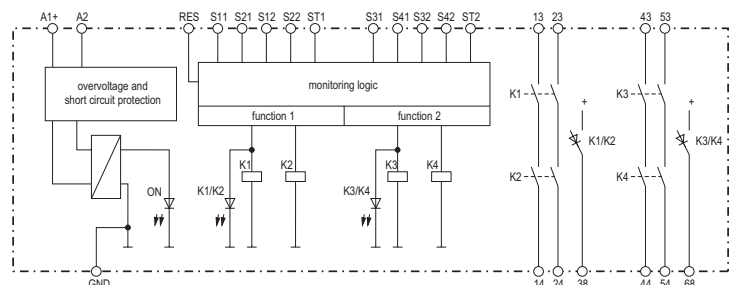

Dimensions

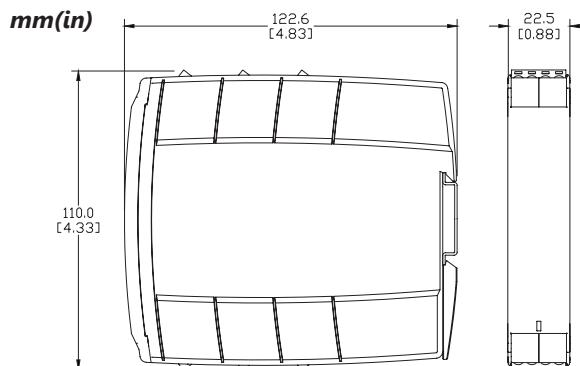

Dold UG6970 Series Safety Relay 2 With Independent Selectable Function

Dold UG6970 Series Safety Relay 2 with Independent Selectable Function Specification Table	
General Specifications	
Temperature	Storage: -25°C to 85°C (-13°F to 185°F) Operating: -15°C to 55°C (5°F to 131°F)
Altitude	<2,000 meters
Vibration Resistance	Amplitude: 0.35mm, Frequency: 10 to 55 Hz (IEC/EN 60-068-2-6)
Degree of Protection	Per IEC/EN 60 529. Housing: IP40; Terminals IP20
Housing	UL 94V-0 Thermoplastic; DIN mount 35 mm x 7.5 mm
Weight	275g (9.7 oz.)
Terminal Designation per EN 60 000 Wire Connections	1x4 mm ² solid or 1 x 2.5 mm ² stranded ferruled (isolated) or 2 x 1.5 mm ² stranded ferruled (isolated) DIN 46 228-1/-2/-3/-4 or 2 x 2.5 mm ² solid DIN 46 228-1/-2/-3/-4
Wire Fixing	Terminal screws M3.5 box terminals with wire protection.
Wire Connection	60degC/75degC Copper conductors only; AWG20-12 Sol/Str Torque 0.5NM
Input Specifications	
Nominal Voltage	24VDC
Voltage Range	At 10% residual ripple: DC: 0.8 to 1.1 U _N
Maximum Consumption	DC approx. 3.2W
Nominal Frequency	Not applicable
Minimum Off-time	250ms
Control Voltage on S11 At UN	20VDC
Control Current Typ. Over S12, S22	8mA at U _N
Min. Voltage on S12, S22 (relay activated)	10VDC
Short Circuit Protection	Internal with PTC (Positive Temperature Coefficient resistor)
Overvoltage Protection	Internal VDR (Voltage Dependent Resistor)
Output Specifications	
Electrical Contact Life	AC 15 at 5A, 230VAC: > 1.5x10 ⁵ switching cycles
Mechanical Life	> 10x10 ⁶ switching cycles
Contact Type	Independent N.O. positive-guided safety contacts (2 per safety function)
Operate Delay	Manual start: 30ms; automatic start: 350ms
Release Delay	E-Stop (1) (6), Safety gate (2) (7), Exclusive or contacts (5): Start up at U : < 65ms Release delay at U and disconnecting the supply: < 40ms Release delay at U and disconnecting S12,S22: < 60ms Two-hand control (3) Start up at U : < 110ms Release delay at U and disconnecting the supply: < 40ms Release delay at U and disconnecting S12,S22: < 60ms Simultaneity demand: max. 0,5 s Safety mat (4) Start up at U : < 85ms Release delay at U and disconnecting the supply: < 40ms Release delay at U and disconnecting S12,S22: < 60ms Light curtains (8) Start up at U : < 35ms Release delay at U and disconnecting the supply: < 40ms Release delay at U and disconnecting S12,S22: < 25ms
Nominal Output Voltage	AC: 24VDC: See continuous current limit curve in installation manual.
Thermal Current (I_{th})	Max. 8A. See quadratic total current limit curve in installation manual.
Short Circuit Strength	Max. fuse rating: 6A gL (IEC/EN 60 947-5-1); Line circuit breaker: B 6A
Switching Capacity (IEC/EN 60 947-5-1)	AC 15: N.O. contacts: 3A/230V DC 13: N.O. contacts: 2A/DC24V
Switching Frequency	Safety function 1: Max. 1800 switching cycles/hr Safety function 1: Max. 360 switching cycles/hr
Agency Approvals and Standards	CSA, cULus file E107778, CE, RoHS, TUV

To obtain the most current agency approval information, see the Agency Approval Checklist section on the specific part number's web page at _____

Dold UG6970 Series Safety Relay 2 With Independent Selectable Function

Application Examples

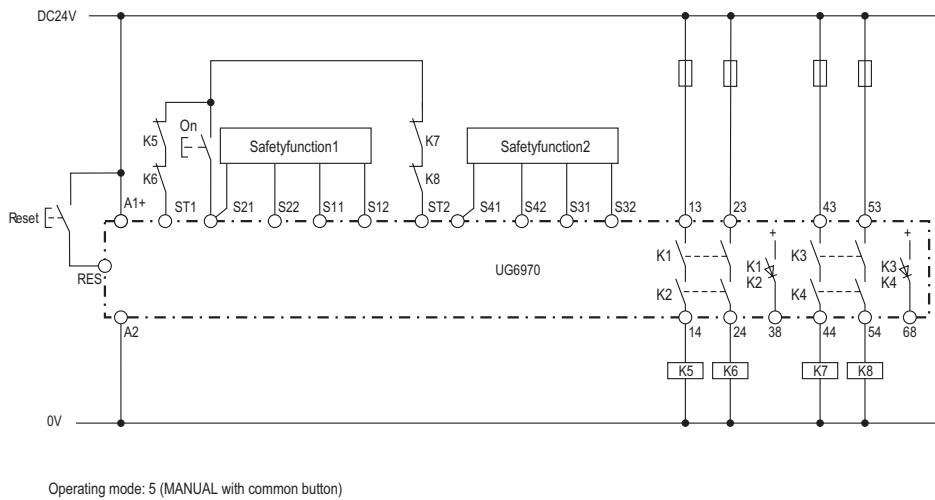
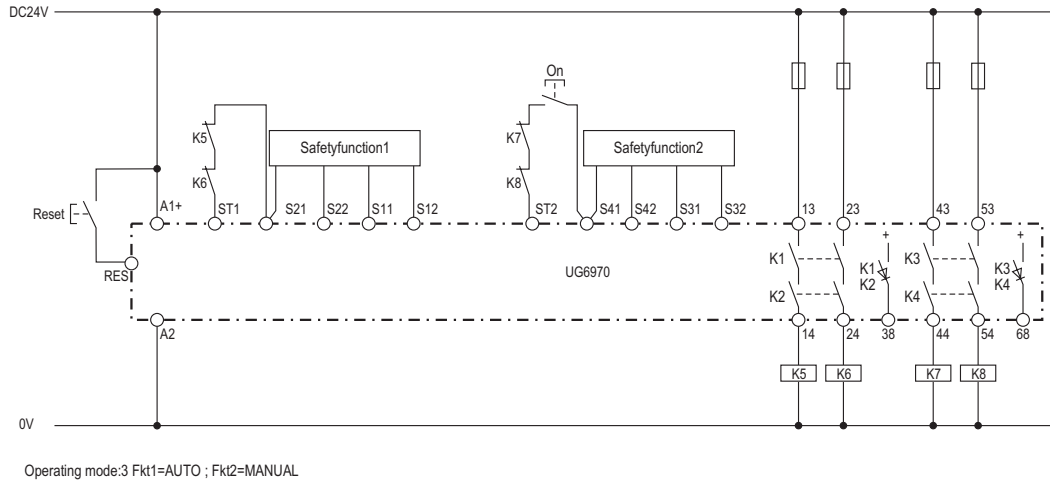

Note: See page tESC-319 for Safety Function example drawings.

Dold UG6970 Series Safety Relay 2 With Independent Selectable Function

Safety Functions

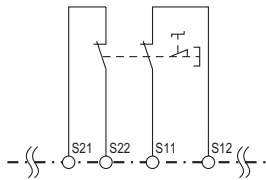

Fct.: E-stop (1),
with cross fault detection
SIL 3, PL e, Cat. 4

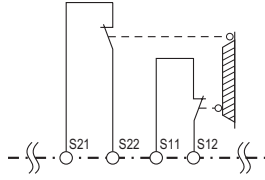

Fct.: Safety gate (2),
with cross fault detection
SIL 3, PL e, Cat. 4

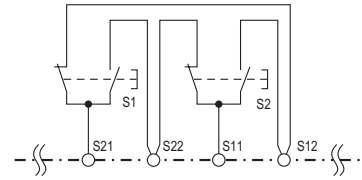

Fct.: Two-hand control (3),
with cross fault detection
SIL 3, PL e, Cat. 4
Type III C to EN 574

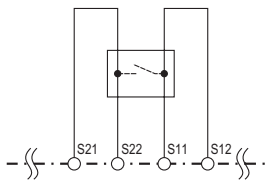

Fct.: Safety mat / Safety edge (4),
with cross fault detection
SIL 3, PL e, Cat. 4

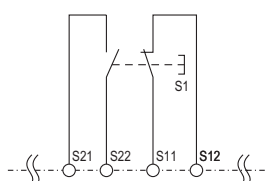

Fct.: Exclusive XOR contacts (5),
with cross fault detection
SIL 3, PL e, Cat. 4

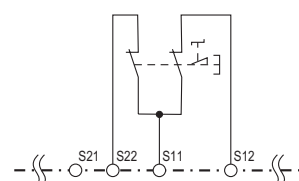

Fct.: E-Stop (6),
without cross fault detection
SIL 3, PL e, Cat. 4¹⁾

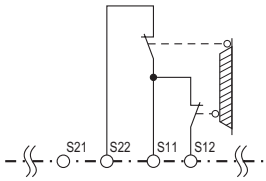

Fct.: Safety gate (7),
without cross fault detection
SIL 3, PL e, Cat. 4¹⁾

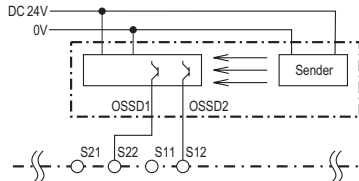

Fct.: Light curtain (8),
without cross fault detection
SIL 3, PL e, Cat. 4²⁾

¹⁾To achieve the stated safety classification the wiring has to be done with crossfault monitoring.
²⁾To achieve the stated safety classification light curtains with selftest (type 4) according to IEC/EN 61496-1 have to be used.

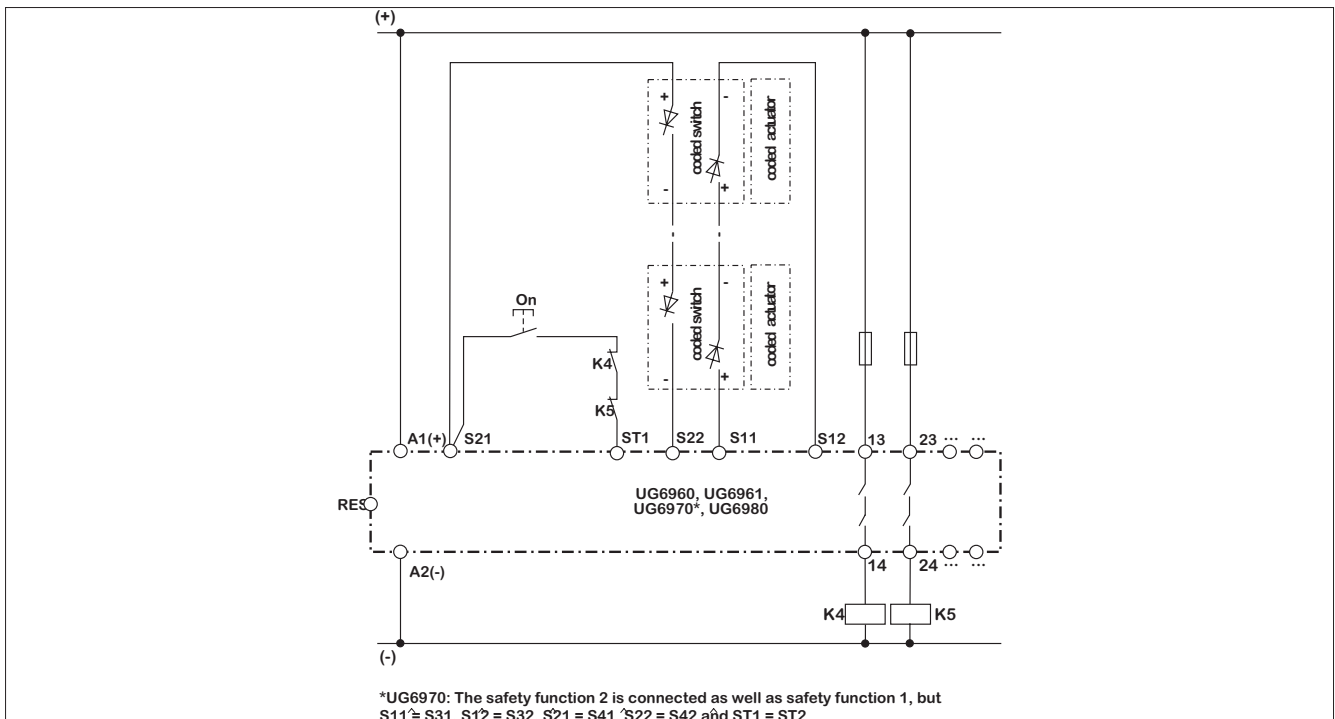

*UG6970: The safety function 2 is connected as well as safety function 1, but
S11≙S31, S12≙S32, S21≙S41, S22≙S42 and ST1≙ST2

Dold UG6970 Series Safety Relay 2 With Independent Selectable Function

Connection Terminals

Terminal designation	Signal designation
A1 +	DC 24 V
A2	0 V
13, 14, 23, 24, 43, 44, 53, 54	Forcibly guided NO contacts for release circuit
38, 68	Semiconductor monitoring output
GND	Reference potential for Semiconductor monitoring output
S11, S21, S31, S41	control output
S12, S22, S32, S42, ST1, ST2, RES	control input

Characteristic Curves

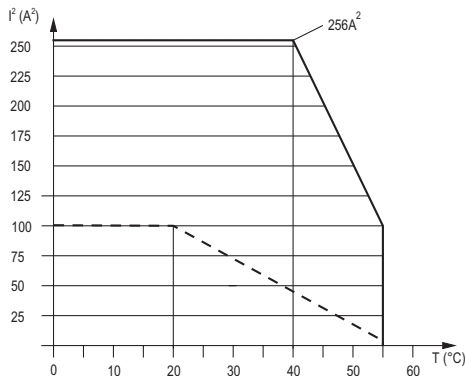

— device free-standing
max. current at 55°C over
4 contact path = $5A \hat{=} 4 \times 5^2 A^2 = 100A^2$

- - - device mounted without distance heated by
devices with same load,
max. current at 55°C over
4 contact path = $1A \hat{=} 4 \times 1^2 A^2 = 4A^2$

$$\sum I^2 = I_1^2 + I_2^2 + I_3^2 + I_4^2$$

I_1, I_2, I_3 - current in contact paths

Quadratic total current limit curve output contacts

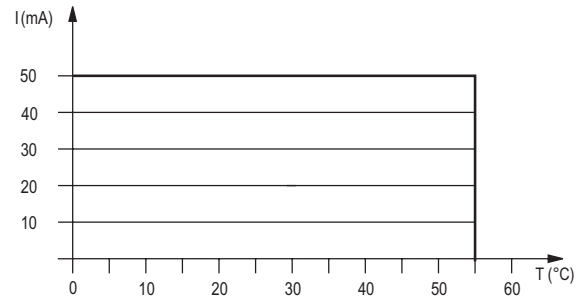

$\sum I = I_{38} + I_{68}$
z.B. : $\sum I = 35mA + 15mA = 50mA$
 I_{38} - current semiconductor output 38
 I_{68} - current semiconductor output 68

Quadratic total current limit curve semiconductor monitoring outputs

Function Setting

Fkt. 1/Fkt. 2	Safety Function	
1	E-Stop	Cross fault detection
2	Safety Gate	
3	Two-hand Control	
4	Safety mat / safety edge	
5	Exclusive XOR contacts	
6	E-stop	Without cross fault defection
7	Safety gate	
8	Light curtain	

Safety Products



Warning: Safety products sold by AutomationDirect are Safety components only. The purchaser/installer is solely responsible for the application of these components and ensuring all necessary steps have been taken to assure each application and use meets all performance and applicable safety requirements and/or local, national and/or international safety codes as required by the application. AutomationDirect cannot certify that our products, used solely or in conjunction with other AutomationDirect or other vendors' products, will assure safety for any application. Any person using or applying any products sold by AutomationDirect is responsible for learning the safety requirements for their individual application and applying them, and therefore assumes all risks, and accepts full and complete responsibility, for the selection and suitability of the product for their respective application.

AutomationDirect does not provide design or consulting services, and cannot advise whether any specific application or use of our products would ensure compliance with the safety requirements for any application.