

Dold UG6980 Series Safety Relay With Selectable Function



Designed to protect people and machines in applications with various safety devices.

- Adjustable safety functions (power off before selecting the desired function):
 - E-Stop
 - Safety gate
 - Two-hand control
 - Safety mat / Safety edge
 - Exclusive XOR contacts
 - Light curtain

- According to:
 - Performance Level (PL) e and category 4 to EN ISO 13849-1: 2008
 - SIL Claimed Level (SIL CL) 3 to IEC/EN 62061
 - Safety Integrity Level (SIL) 3 to IEC/EN 61508 and IEC/EN 61511
 - Acc. to EN 50156-1 for furnaces
- Line fault detection on pushbutton:
- Manual restart or automatic restart
- With or without cross fault monitoring
- 2-channel
- Forcibly guided output contacts
- Output: 2 N.O. contacts per safety function
- One semiconductor output per safety function
- LED indicator for operation, safety function 1, 2 and failure
- Pluggable terminal blocks for easy exchange of devices
- Two PNP sensor inputs only

Safety Data – Values per EN ISO 13849-1	
Category	4
Performance level	PLe
MTTF _d	>100 years
DC _{avg}	99%
Safety Data – Values per IEC/EN 62061 /IEC/EN 61508	
SIL CL	3
SIL	3
HFT (Hardware Failure Tolerance)	1
DC _{avg}	99%
SFF	99.7%
PFH _D	1.88E-10 h ⁻¹

Safety Relays Selection Chart				
Part Number	Price	Marking Type	Voltage	Outputs
UG6980-02PS-61-24		Safety relay module	24VDC	2 N.O. positive guided safety contact(s), 1 N.O. monitoring contact(s)

Function Diagram

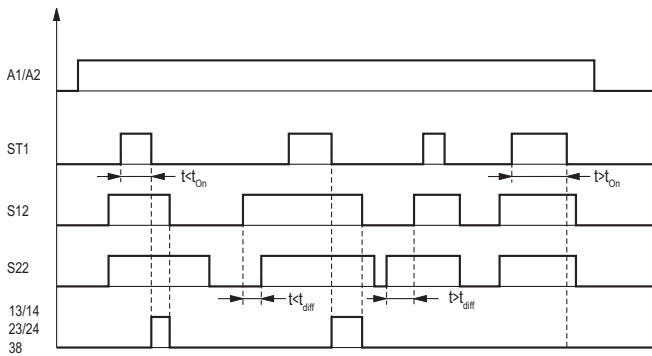

t_{diff} : max. time delay for simultaneity demand dependent on selected safety function
 E-Stop, safety gate, safety mat t_{diff} : max. 3s
 Light curtains t_{diff} : max. 1s
 Two-hand control t_{diff} : max. 0,5s
 other times on request

t_{on} : max. actuation time of start button
 Standard t_{on} : max. 3s
 other times on request

Block Diagram

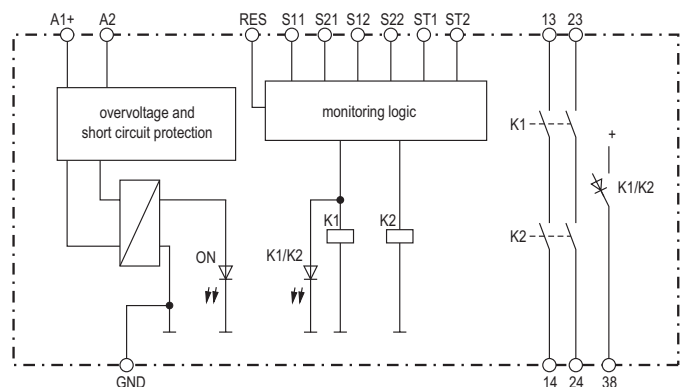

Dold UG6980 Series Safety Relay With Selectable Function

Dold UG6980 Series Safety Relay with Selectable Function Specification Table	
General Specifications	
Temperature	Storage: -25°C to 85°C (-13°F to 185°F) Operating: -15°C to 55°C (5°F to 131°F)
Altitude	<2,000 meters
Vibration Resistance	Amplitude: 0.35mm, Frequency: 10 to 55 Hz (IEC/EN 60-068-2-6)
Degree of Protection	Per IEC/EN 60 529. Housing: IP40; Terminals IP20
Housing	UL 94V-0 Thermoplastic; DIN mount 35mm x 7.5 mm
Weight	210g (7.40 oz.)
Terminal Designation per EN 50 005 Wire Connections	1x4 mm ² solid or 1 x 2.5 mm ² stranded ferruled (isolated) or 2 x 1.5 mm ² stranded ferruled (isolated) DIN 46 228-1/-2/-3/-4 or 2 x 2.5 mm ² solid DIN 46 228-1/-2/-3/-4
Wire Fixing	Terminal screws M3.5 box terminals with wire protection.
Wire Connection	60degC/75degC Copper conductors only; AWG20-12 Sol/Str Torque 0.5NM
Input Specifications	
Nominal Voltage	24VDC
Voltage Range	At 10% residual ripple: 0.8 to 1.1 U _N
Maximum Consumption	DC approx. 1.9W
Nominal Frequency	Not applicable
Minimum Off-time	250ms
Control Voltage on S11, S21, S31, S41 At UN	20VDC pulsed, 10ms ON, 10ms OFF
Control Current Over S12, S22, S32, S42	Typ. 8mA at UN; Safety mats: Typ. 15mA at U _N
Min. Voltage on S12, S22, S32, S42 (relay activated)	10VDC
Short Circuit Protection	Internal with PTC (Positive Temperature Coefficient resistor)
Overvoltage Protection	Internal VDR (Voltage Dependent Resistor)
Output Specifications	
Electrical Contact Life	AC 15 at 5A, 230VAC: > 2.2x10 ⁵ switching cycles
Mechanical Life	> 20x10 ⁶ switching cycles
Contact Type	2 positive guided N.O. safety contacts
Operate Delay	Manual start: 30ms; automatic start: 350ms
Release Delay	Disconnecting the supply: AC units: 150ms; DC units: 50ms Disconnecting S12, S22: AC units: 130ms. DC units: 50ms
Nominal Output Voltage	AC: 250V; DC: See continuous current limit curve in installation manual.
Thermal Current (I_{th})	Max. 8A. See quadratic total current limit curve in installation manual.
Short Circuit Strength	Max. fuse rating: 6A gL (IEC/EN 60 947-5-1); Line circuit breaker: B 6A
Switching Capacity (IEC/EN 60 947-5-1)	AC 15: N.O. contacts: 3A/230V; N.C. contacts: 2A/230V DC 13: N.O. contacts: 4A/DC24V. 0.5A/110V; N.C. contacts: 4A/24V; DC 13: N.O. contacts: 8A/24V >25x103. ON: 0.4 s, OFF: 9.6 s
Switching Frequency	Max. 1200 switching cycles/hr
Agency Approvals and Standards	CSA, cULus file E107778, CE, RoHS, TUV

To obtain the most current agency approval information, see the Agency Approval Checklist section on the specific part number's web page at _____

Settings

Setting

On the variant /0_ _ the safety function can be set via rotary switch.

Possible functions:

Fct.	Safety function	
1	E-Stop	cross fault detection
2	Safety gate	
3	Two-hand control	
4	Safety mat / Safety edge	
5	Exclusive or contacts	
6	E-Stop	without cross fault detection
7	Safety gate	
8	Light curtain	

Dold UG6980 Series Safety Relay With Selectable Function

Applications

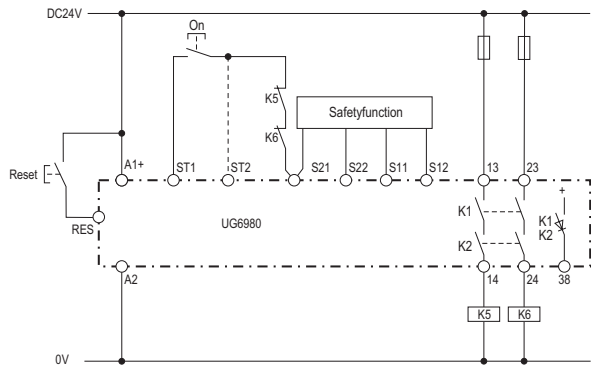

Safety function: see below, Manual-Start (for automatic start make a bridge to ST2 instead of ON button).

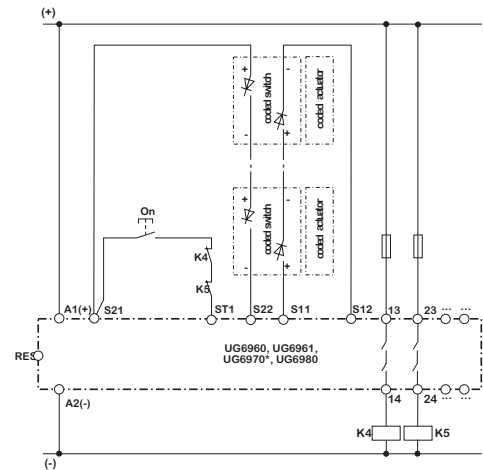

*UG6970: The safety function 2 is connected as well as safety function 1, but S11² S31, S12 = S32, S21 = S41, S22 = S42 and ST1 = ST2

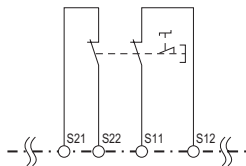

Fct.: E-stop (1), with cross fault detection SIL 3, PL e, Cat. 4

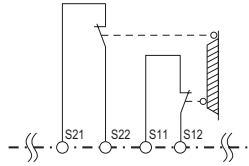

Fct.: Safety gate (2), with cross fault detection SIL 3, PL e, Cat. 4

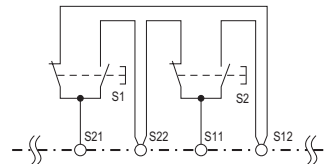

Fct.: Two-hand control (3), with cross fault detection SIL 3, PL e, Cat. 4 Type III C to EN 574

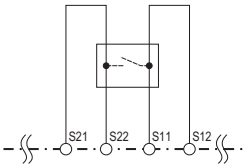

Fct.: Safety mat / Safety edge (4), with cross fault detection SIL 3, PL e, Cat. 4

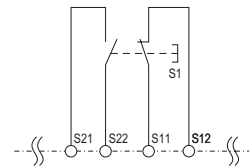

Fct.: Exclusive XOR contacts (5), with cross fault detection SIL 3, PL e, Cat. 4

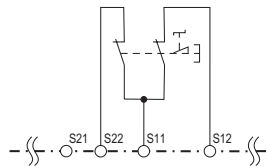

Fct.: E-Stop (6), without cross fault detection SIL 3, PL e, Cat. 4 ¹⁾

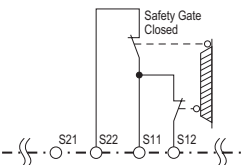

Fct.: Safety gate (7), without cross fault detection SIL 3, PL e, Cat. 4 ¹⁾

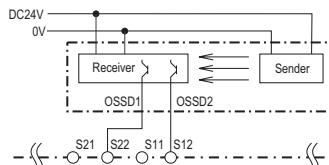

Fct.: Light curtain (8), without cross fault detection SIL 3, PL e, Cat. 4 ²⁾

¹⁾ To achieve the stated safety classification the wiring has to be done with crossfault monitoring.

²⁾ To achieve the stated safety classification light curtains with selftest (type 4) according to IEC/EN 61496-1 have to be used.

Dold UG6980 Series Safety Relay With Selectable Function

Characteristic Curves

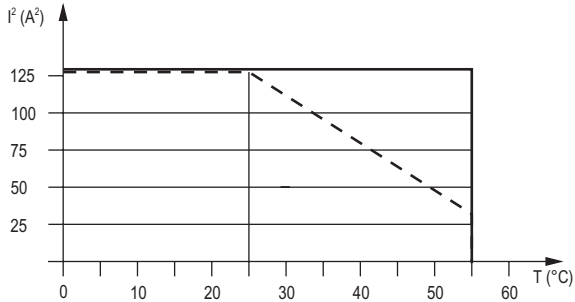

— device free-standing
max. current at 55°C over
2 contact path = $8A \triangleq 2 \times 8^2 A^2 = 128A^2$

- - - device mounted without distance heated by
devices with same load,
max. current at 55°C over
2 contact path = $4A \triangleq 2 \times 4^2 A^2 = 32A^2$

$$\sum I^2 = I_1^2 + I_2^2$$

I_1, I_2 - current in contact paths

UG 6980.02
Quadratic total current limit curve

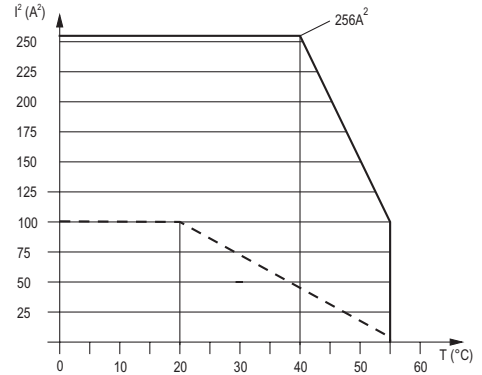

— device free-standing
max. current at 55°C over
4 contact path = $5A \triangleq 4 \times 5^2 A^2 = 100A^2$

- - - device mounted without distance heated by
devices with same load,
max. current at 55°C over
4 contact path = $1A \triangleq 4 \times 1^2 A^2 = 4A^2$

$$\sum I^2 = I_1^2 + I_2^2 + I_3^2 + I_4^2$$

I_1, I_2, I_3, I_4 - current in contact paths

Quadratic total current limit curve output contacts

Dimensions mm(in)

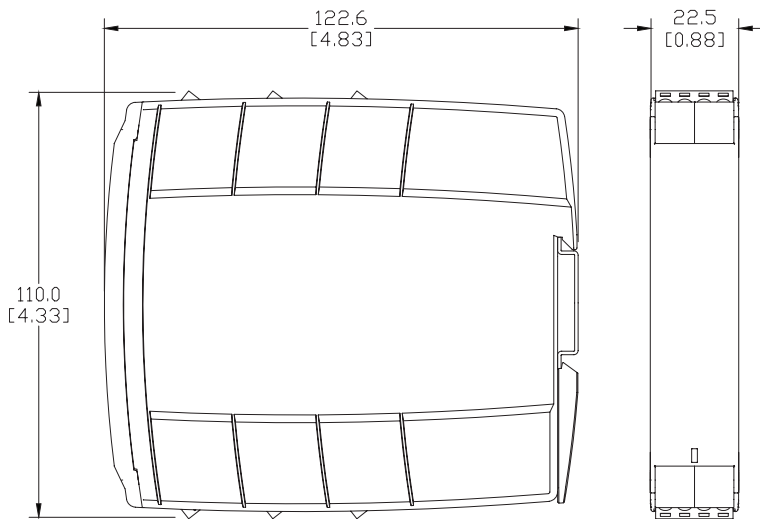

Connection Terminals

Terminal designation	Signal designation
A1 +	DC 24 V
A2	0 V
13, 14, 23, 24, 43, 44, 53, 54	Forcibly guided NO contacts for release circuit
38	Semiconductor monitoring output
GND	Reference potential for Semiconductor monitoring output
S11, S21	control output
S12, S22, ST1, ST2, RES	control input

Safety Products



Warning: Safety products sold by AutomationDirect are Safety components only. The purchaser/installer is solely responsible for the application of these components and ensuring all necessary steps have been taken to assure each application and use meets all performance and applicable safety requirements and/or local, national and/or international safety codes as required by the application. AutomationDirect cannot certify that our products, used solely or in conjunction with other AutomationDirect or other vendors' products, will assure safety for any application. Any person using or applying any products sold by AutomationDirect is responsible for learning the safety requirements for their individual application and applying them, and therefore assumes all risks, and accepts full and complete responsibility, for the selection and suitability of the product for their respective application.

AutomationDirect does not provide design or consulting services, and cannot advise whether any specific application or use of our products would ensure compliance with the safety requirements for any application.