

Dold LH5946 Standstill Monitor Relays



LH5946 speed monitoring safety relay modules provide safe standstill detection on 3-phase and single-phase motors by monitoring remanence voltage.

- Can monitor motor voltages up to 690 VAC or VDC
- No external sensors necessary
- Independent of direction
- Broken wire detection

- Monitors rotation and linear movement
- 2-channel operation for standstill monitoring
- 3 N.O. and 1 N.C. positive-guided safety contacts
- LED status indicator
- Adjustable voltage setting
- Adjustable standstill time delay
- Semiconductor outputs for monitoring

Safety Standstill Monitor Relays Selection Chart

Part Number	Price	Marking Type	Voltage Monitor Range	Voltage	Outputs
LH5946-48-24-04		Standstill-monitoring safety relay module	20mV to 400mV	24 VDC	3 N.O./1 N.C.
LH5946-48-115-04				115 VAC	
LH5946-48-230-04		Please consider LH5946-48-24-04 as a comparable replacement.			
LH5946-48-24-40		Standstill-monitoring safety relay module	200mV to 4V	24 VDC	3 N.O./1 N.C.
LH5946-48-115-40				115 VAC	
LH5946-48-230-40		Please consider LH5946-48-24-40 as a comparable replacement.			

Note: The -04 models are recommended for applications where motors are controlled directly from contactors. The -40 models are recommended for applications involving VFDs or soft starters where OFF-state leakage is present and higher voltage settings are required.

Safety Standstill Monitor Relays Specification Table

General Specifications																			
Temperature	Storage: -40°C to 75°C (-40°F to 167°F) Operating: -25°C to 60°C (-13°F to 140°F)																		
Altitude	< 2,000 meters																		
Vibration Resistance	Amplitude: 0.35mm, Frequency: 10 to 55 Hz (IEC/EN 60-068-2-6)																		
Degree of Protection	Per IEC/EN 60 529. Housing: IP40; Terminals IP20																		
Housing	UL 94V-0 Thermoplastic; Din mount 35 mm x 7.5 mm																		
Weight	400g (14.11 oz.)																		
Agency Approvals and Standards	cULus file E107778, CE, RoHS, TUV																		
Terminal Designation per EN 50 005 Wire Connections	1x4 mm ² solid or 1 x 2.5 mm ² stranded ferruled (isolated) or 2 x 1.5 mm ² stranded ferruled (isolated) DIN 46 228-1/-2/-3/-4 or 2 x 2.5 mm ² solid per DIN 46 228-1/-2/-3 /-4																		
Wire Fixing	Plus-minus terminal screws M3.5 box terminals with wire protection. Torque 0.8 Nm (7 lb-in)																		
Input Specifications																			
Nominal Voltage	24V DC, 115 V AC, 230V AC																		
Measuring/Motor Voltage	690 V																		
Input Resistance	500 k ohms																		
Response Value U_{an}	20 mV to 400 mV, adjustable or 0.2 to 4V adjustable																		
Response Value Dependent on Frequency	<table border="1"> <thead> <tr> <th>Input Frequency (Hz)</th> <th>50</th> <th>100</th> <th>200</th> <th>400</th> <th>600</th> <th>1k</th> <th>1.5k</th> <th>2k</th> </tr> </thead> <tbody> <tr> <td>Response Value U_{an}</td> <td>1.0</td> <td>1.1</td> <td>1.2</td> <td>1.5</td> <td>2.0</td> <td>2.8</td> <td>5</td> <td>8</td> </tr> </tbody> </table>	Input Frequency (Hz)	50	100	200	400	600	1k	1.5k	2k	Response Value U_{an}	1.0	1.1	1.2	1.5	2.0	2.8	5	8
Input Frequency (Hz)	50	100	200	400	600	1k	1.5k	2k											
Response Value U_{an}	1.0	1.1	1.2	1.5	2.0	2.8	5	8											
Voltage Range	AC: 0.8 to 1.1 UN. At 10% residual ripple: 0.9 to 1.1 UN; At 48% residual ripple: 0.85 to 1.1 UN DC: 0.9 to 1.2 UN. At 10% residual ripple: 0.9 to 1.1 UN; At 48% residual ripple: 0.85 to 1.1 UN																		
Nominal Consumption	ca. 5 VA, 3W																		
Nominal Frequency	50 to 60 Hz. Frequency range: 45 to 65 Hz																		
Control Current	Control current typ. at 24V over 2 relays: 75 mA																		
Overvoltage Protection	Internal VDR (Voltage Dependent Resistor)																		
Output Specifications																			
Electrical Contact Life	To AC15 at 2 A, 230V: 2x10 ⁵ switching cycles IEC/EN 60 947-5-1																		
Mechanical Life	M50 x 106 switching cycles																		
Contact Type	3 N.O. positively driven and 1 N.C. relay contacts (N.O. contacts are safety contacts)																		
Operate Delay on Standstill	Depends on setting; adjust by potentiometer																		
Release Delay on Overspeed	t_{off} = typ. 700 ms																		
Nominal Output Voltage	250VAC																		
Thermal Current (I _{th})	Max. 5A per contact. See continuous current limit curve in installation manual.																		
Short Circuit Strength	Max fuse rating: 4A gl (IEC/EN 60 9470-5-1), line circuit breaker C6A																		
Switching Capacity IEC/EN 60 947-5-1	AC 15: N.O. contacts: 3A/230V; N.C. contacts: 2A/230VAC. DC13: 2A/24V																		
Switching Frequency	Max. 1,200 switching cycles/hr																		
Semi-conductor Monitoring	100 mA DC 24V; supply via A3+/A4																		

Dold LH5946 Standstill Monitor Relays

Dimensions

mm [in]

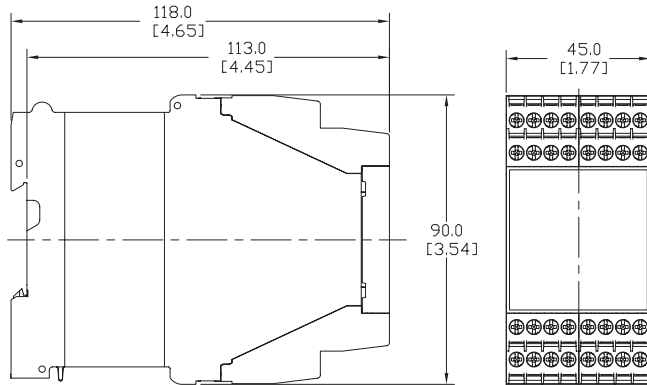

Safety Data – Values per EN ISO 13849-1	
Category	4 according to EN 954-1
Performance level	PLe according to EN 13849-1
MTTF _d	>93 years
DC _{avg}	99%
Safety Data – Values per IEC/EN 62061 /IEC/EN 61508	
SIL CL	3 per IEC/EN 62061
SIL	3 per IEC/EN 61508
HFT (Hardware Failure Tolerance)	1
DC _{avg}	99%
SFF	99.7%
PFH _D	4.10E-10 h ⁻¹

Function diagram

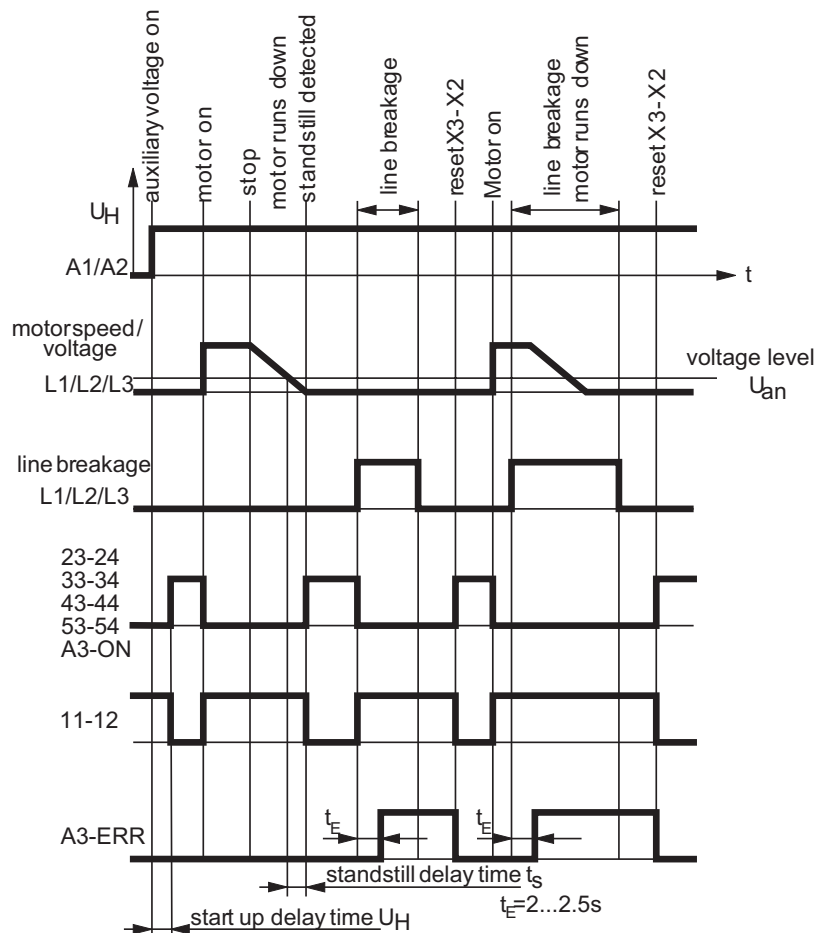

Dold LH5946 Standstill Monitor Relays

Applications

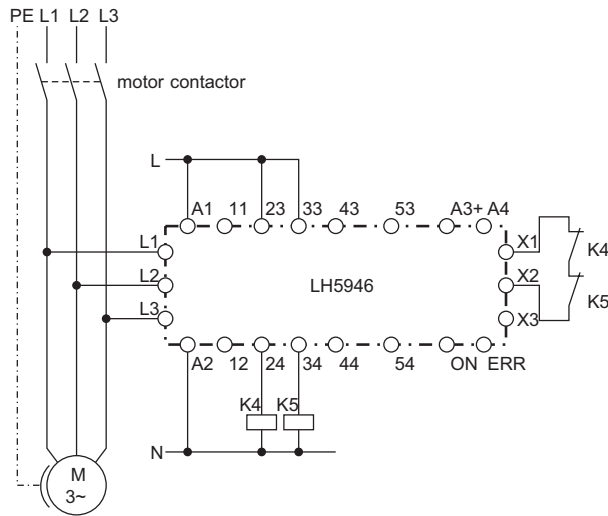

With 3-phase motor

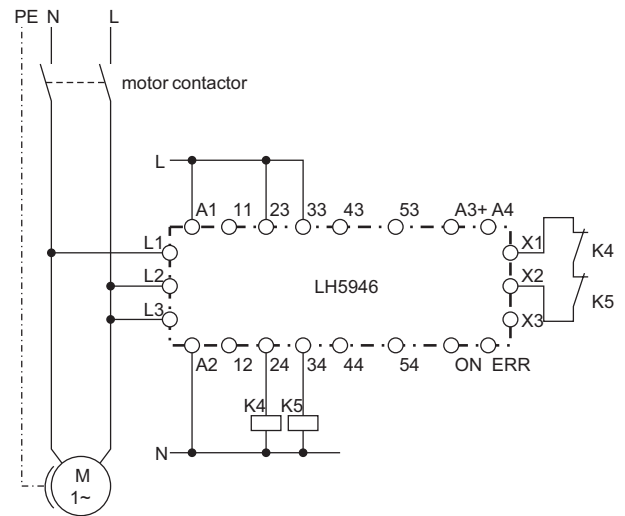

With single-phase motor

Connection terminals

Terminal designation	Signal designation
L1 - L2 - L3	Connection to monitored motor
11 - 12	Safety contacts (NC)
23 - 24, 33 - 34, 43 - 44	Safety contacts (NO)
53 - 54	Monitoring contact (NO)
X1 - X2	Connection of feedback circuit (for external contactors)
X2 - X3	Manual reset for external faults
A1 - A2	Auxiliary supply (U_H)
A3(+)- A4	Supply for semiconductor outputs
ON:	Semiconductor output indicates state of safety contacts
ERR:	Semiconductor output indicates failures
Attention: The outputs 53-54, ON and ERR are only monitoring outputs and must not be used in safety circuits	

Setting

Poti „ U_{an} “:	Adjustment of voltage level for standstill detection
Poti „ t_s “:	Adjustment of time delay before activation of safety contacts

Safety Products



Warning: Safety products sold by AutomationDirect are Safety components only. The purchaser/installer is solely responsible for the application of these components and ensuring all necessary steps have been taken to assure each application and use meets all performance and applicable safety requirements and/or local, national and/or international safety codes as required by the application. AutomationDirect cannot certify that our products, used solely or in conjunction with other AutomationDirect or other vendors' products, will assure safety for any application. Any person using or applying any products sold by AutomationDirect is responsible for learning the safety requirements for their individual application and applying them, and therefore assumes all risks, and accepts full and complete responsibility, for the selection and suitability of the product for their respective application.

AutomationDirect does not provide design or consulting services, and cannot advise whether any specific application or use of our products would ensure compliance with the safety requirements for any application.