

Stellar® SR55 Full-Featured Soft Starters

Overview

SR55 full-featured solid-state Soft Starters provide many advantages when used instead of electromechanical contactors to control 3-phase AC induction motors. The SR55 Soft Starters are fully digital, and use thyristors in all three motor phases for controlled reduced voltage motor starting and stopping. SR55's have an Automatic Application Setup that fully configures the starter for a specific application with one entry. SR55's also have a built-in internal bypass and patented iERS (intelligent Energy Recovery System) that reduces energy costs when used on lightly loaded and oversized motors.

Features

- 17-477A @ 200-480VAC
- 24VDC, 110VAC, or 230VAC selectable control voltage
- Internally bypassed during run
- Full three-phase motor control
- Built-in SCR failure protection
- Full motor overload protection
- Full data logging (fault records, motor current, operational status, etc.)
- Fully programmable
- Easily and separately adjustable motor start and stop times
- iERS (intelligent Energy Recovery System) saves energy on lightly-loaded motors
- Can be connected 'in-the-delta', allowing use of a smaller Soft Starter (no iERS optimizing with in-delta connections)
- Can be used for motor reversing (with external contactors)
- Suitable for a wide variety of motor loads
- Touchscreen with easy-to-navigate menu structure and quick automatic application set up
- Can be used with local or remote control
- Integrated Modbus RTU, or optional Modbus TCP or EtherNet/IP communication
- Optional remote touchscreen available
- Programmable analog I/O, digital inputs, and relay outputs for remote control
- Fault record history of last 10 trips (using the download fault log will give faults and running data for the life of the SR55)
- IP20, panel mount with optional finger guards for frame sizes 1 and 2 soft starters
- Two-year warranty
- CE, ETL (CSA C22.2 No.14 and UL 508), REACH, RoHS
- Auto Reset Feature available

Advantages

Mechanical Advantages

- Smaller physical size than equivalent SR44 models (even with the built-in bypass contactors)
- Smooth acceleration; reduced mechanical shock and starting stress
- Extend lifespan of mechanical drive-train components
- Fluid couplings and some clutches can be eliminated

Electrical Advantages

- Reduced starting currents and spikes
- More motors or larger motors can be started from lower-capacity power sources
- Allows motors to be started more frequently

Economic Advantages

- Lower overall costs for new installations
- Bypass relays built in
- Reduced maintenance and replacement of mechanical drive-train components
- Reduced starting current lowers demand charges
- iERS (intelligent Energy Recovery System) reduces electrical power costs
- Automatic Application setup feature speeds installation by configuring the SR55 for a specific application with one setting

Optional Accessories

- EtherNet/IP communication module
- Modbus TCP communication module
- Modbus serial communication splitter
- RJ12 to RJ45 adapter
- Power terminal IP20 finger guards
- Remote touchscreen
- Replacement touchscreen
- Replacement cooling fans

Applications

- General purpose applications where traditional cross-the-line starting or wye-delta starting would typically be appropriate
- Applications with oversized or lightly loaded motors (iERS reduces energy usage)
- Applications requiring lower inrush currents



Stellar® SR55 Full-Featured Soft Starters

SR55 Soft Starter Technical Specifications

SR55 Series Full-Featured Soft Starters – 17A–96A *									
Model	SR55-017	SR55-021	SR55-027	SR55-034	SR55-040	SR55-052	SR55-065	SR55-077	SR55-096
Frame Size	1								
Price	8.00	7.00	9.00	7.00	3.00	4.00	1.00	5.00	4.00
* Rated Current I _e (A)	17	21	27	34	40	52	65	77	96
Rated Operational Voltage	200VAC to 480VAC								
* Motor Rating @ 200V (hp)	3	5	7.5	10	10	15	20	20	30
* Motor Rating @ 208V (hp)	5	5	7.5	10	10	15	20	25	30
* Motor Rating @ 230V (hp)	5	5	7.5	10	10	15	20	25	30
* Motor Rating @ 460V (hp)	10	15	20	25	30	40	50	60	75
Trip Class	programmable 10 to 30								
Index Rating [per IEC 60947-4-2]	Ie: AC-53a: 3.5–17: 90–5								
Impulse Withstand Voltage	4kV								
Insulation Voltage Rating	480V								
Short Circuit Current Rating (type 1) (kA)	5							10	
Control Power Consumption	60W inrush to latch internal bypass relays; 4W steady state								
Control Voltage Range	24VDC +10%-15% or 110–230VAC +10%-15%								
Control Fuse (external)	4A								
Control Inputs	(3) DI @ 24VDC, 110VAC, or 230VAC; (1) PTC Thermistor; (1) AI @ 0–10VDC 10mA max or 4–20mA								
Control Outputs	(3) N/O relay and (1) N/C relay @ 30VDC 0.5A / 230VAC 1A resistive; (1) AO @ 0–10VDC 10mA max or 4–20mA								
** Start Time Setting Range (s)	1 to 300								
Start Voltage Setting Range (%)	10 to 100								
** Stop Time Setting Range (s)	0 to 300								
Ambient Operating Temperature	-20°C [-4°F] to 50°C [122°F]; above 50°C derate linearly by 4% of SR55 I _e per °C to a maximum of 60°C (140°F)								
Transportation & Storage Temperature	-20°C to 60°C [-4°F to 140°F] continuous								
Humidity	max 85% non-condensing, not exceeding 50% @ 40°C [104°F]								
Maximum Altitude	1,000m [3,281ft]; above 1000m derate by 1% of SR55 I _e per 100m (328ft) to a maximum altitude of 2000m (6562ft)								
Environmental Rating	Main Circuit: IP00 (IP20 with optional finger guards for sizes 1&2 only); Control Circuit: IP20 No corrosive gases permitted								
Weight (lb [kg])	6.6 [3.0]				7.7 [3.5]				
*** Agency Approvals	CE, CSA C22.2 No.14 (ETL tested), ETL 4004274, REACH, RoHS, UL508 (ETL tested)								

* Refer to Selection Table for deratings by application and overload trip class.

Important: Care must be taken to select the correct SR55 for the application to ensure that the SR55 is not undersized. Refer to Selection Tables or to online selection tool for deratings by application and overload trip class (<https://www.stellarsoftstarters.com/selectors/softstarters>).

** Start Time and Stop Time define the length of time the soft starter varies the voltage to the motor. While a Variable Frequency Drive (AC Drive) can define motor speed throughout the acceleration and deceleration ramps by varying its output frequency, a soft starter only controls average voltage to the motor and cannot accurately control motor speed. Therefore, motor speed during acceleration and deceleration can vary with load. Example: a conveyor soft starter could have a Start Time of 10s. If the conveyor is empty, the motor may actually reach top speed in 8s. If the conveyor is heavily loaded, the motor may not reach full speed until 10s. For more information, please see the SR55 User Manual - "Appendix B: Soft Starter Application Considerations."

*** To obtain the most current agency approval information, see the Agency Approval Checklist section on the specific part number's web page.

Stellar® SR55 Full-Featured Soft Starters

SR55 Soft Starter Technical Specifications

SR55 Series Full-Featured Soft Starters – 124A–477A *								
Model	SR55-124	SR55-156	SR55-180	SR55-242	SR55-302	SR55-361	SR55-414	SR55-477
Frame Size	2			3				
Price	7.00	2.00	2.00	7.00	5.00	8.00	9.00	2.00
* Rated Current I _e (A)	124	156	180	242	302	361	414	477
Rated Operational Voltage	200VAC to 480VAC							
* Motor Rating @ 200V (hp)	40	50	60	75	100	125	150	150
* Motor Rating @ 208V (hp)	40	50	60	75	100	125	150	150
* Motor Rating @ 230V (hp)	40	60	60	75	100	150	150	150
* Motor Rating @ 460V (hp)	100	125	150	200	250	300	350	400
Trip Class	programmable 10 to 30							
Index Rating [per IEC 60947-4-2]	I _e : AC-53a: 3.5–17: 90–5			I _e : AC-53a: 3.5–17: 90–3				
Impulse Withstand Voltage	4kV							
Insulation Voltage Rating	480V							
Short Circuit Current Rating (type 1)(kA)	10kA			18kA				
Control Power Consumption	60W inrush to latch internal bypass relays; 4W steady state						120W inrush; 4W steady state	
Control Voltage Range	24VDC +10%-15% or 110–230VAC +10%-15%						110VAC +10%-15%	
Control Fuse (external)	4A							
Control Inputs	(3) DI @ 24VDC, 110VAC, or 230VAC; (1) PTC Thermistor; (1) AI @ 0–10VDC 10mA max or 4–20mA							
Control Outputs	(3) N/O relay and (1) N/C relay @ 30VDC 0.5A / 230VAC 1A resistive; (1) AO @ 0–10VDC 10mA max or 4–20mA							
** Start Time Setting Range (s)	1 to 300							
Start Voltage Setting Range (%)	10 to 100							
** Stop Time Setting Range (s)	0 to 300							
Ambient Operating Temperature	-20°C [-4°F] to 50°C [122°F]; above 50°C derate linearly by 4% of SR55 I _e per °C to a maximum of 60°C (140°F)							
Transportation & Storage Temperature	-20°C to 60°C [-4°F to 140°F] continuous							
Humidity	max 85% non-condensing, not exceeding 50% @ 40°C [104°F]							
Maximum Altitude	1,000m [3,281ft]; above 1000m derate by 1% of SR55 I _e per 100m (328ft) to a maximum altitude of 2000m (6562ft)							
Environmental Rating	Main Circuit: IP00 (IP20 with optional finger guards for sizes 1&2 only); Control Circuit: IP20							
Weight (lb [kg])	12.1 [5.5]	14.3 [6.5]	35.3 [16.0]			46.7 [21.2]		
*** Agency Approvals	CE, CSA C22.2 No.14 (ETL tested), ETL 4004274, REACH, RoHS, UL508 (ETL tested)						CE, REACH, RoHS	

* Refer to Selection Table for deratings by application and overload trip class.

Important: Care must be taken to select the correct SR55 for the application to ensure that the SR55 is not undersized. Refer to Selection Tables or to online selection tool for deratings by application and overload trip class (<https://selectors/softstarters>).

** Start Time and Stop Time define the length of time the soft starter varies the voltage to the motor. While a Variable Frequency Drive (AC Drive) can define motor speed throughout the acceleration and deceleration ramps by varying its output frequency, a soft starter only controls average voltage to the motor and cannot accurately control motor speed. Therefore, motor speed during acceleration and deceleration can vary with load. Example: a conveyor soft starter could have a Start Time of 10s. If the conveyor is empty, the motor may actually reach top speed in 8s. If the conveyor is heavily loaded, the motor may not reach full speed until 10s. For more information, please see the SR55 User Manual - "Appendix B: Soft Starter Application Considerations."

*** To obtain the most current agency approval information, see the Agency Approval Checklist section on the specific part number's web page.

Stellar® SR55 Full-Featured Soft Starters

SR55 Energy-Saving iERS Feature

Intelligent Energy Recovery System

iERS is an advanced SR55 feature that can reduce the energy consumed by lightly-loaded (or oversized) motors. iERS matches the power consumption to the load by monitoring and regulating voltage, current, and power factor during the motor starting and running stages. iERS automatically bypasses itself when it is not needed (as the motor approaches full load torque/current), and continues monitoring to re-engage itself as needed (as the required motor torque/current decreases).

In its most basic function, iERS reduces the voltage being fed to the motor when the motor does not need it. While the torque (and therefore current) required by the load stays the same, reducing the voltage to the motor reduces excess magnetizing current inside the motor. For a more detailed explanation of how iERS reduces magnetizing current and saves energy, please see "Chapter 4: Principles of IERS" in the SR55 User Manual.

Many, if not most, AC motor applications are oversized when the motor FLA is compared to actual running current. Oversizing can be due to non-optimal design, but can also occur intentionally: many applications need a larger motor for starting reasons, for available headroom, for future expansion, etc. Other applications may have different motor demands based on loading; think of an "up" escalator. A fully-loaded escalator requires a lot of torque (current), while an empty escalator requires significantly less torque (current) to maintain speed. When the escalator is empty, the motor will not draw as much current as its FLA. When the SR55 senses this reduced torque load, the starter will reduce the voltage to the motor. This reduced voltage results in reduced magnetizing current in the motor (and thereby saves energy). Note that the current required by the load stays the same; only magnetizing current is reduced.



How Much Will iERS Save?

The savings realized by using iERS will vary by application, how heavily the motor is loaded, and the losses internal to the motor. While these factors can be difficult to quantify, the following estimating tools and examples may help predict your potential savings:

Estimating Energy Savings

Basis for estimations:

- 3-phase squirrel cage induction motor, standard type.
- Supply: 380 to 440V, 50Hz.
- Supply voltage > minimum working voltage on motor rating plate.
- Operation 30% rated nameplate full load.

Energy Savings Estimations – Table 1			
4-Pole Motor Size	kW	HP	Estimated Savings (% rated kW)
Less than	5	7.5	10
	22.5	30	6.5
	55	75	3.5
	110	150	2.5
More than	110	150	1.5

Energy Savings Modifying Factors – Table 2			
Motor Poles		Motor Slip	
Number of Poles	Add (% kW)	% Slip	Add (% kW)
2	-0.5	0.5	-0.5
4	0	2	0
6	0.5	3.3	0.5
8	1	5	1

Examples of estimated savings:

1) 37.5 kW 4-pole motor

From Table 1, use the estimated savings figure for the next higher rating, i.e. 55 kW = 3.5% of full rated kW.

The savings would be approximately 3.5% x 37.5 kW = 1.3125 kW.
Savings % = kW saved / (30% loaded motor kW)
= 1.3125 kW / (30% x 37.5 kW) = 12%.

2) 37.5 kW 2-pole motor

From Table 1, use the estimated savings figure for the next higher rating, i.e. 55 kW = 3.5% of full rated kW.

From Table 2, apply the pole-number factor of -0.5 %.

The savings would be approximately (3.5 % - 0.5 %) x 37.5 kW = 1.125 kW.

Savings % = kW saved / (30% loaded motor kW)
= 1.125 kW / (30% x 37.5 kW) = 10%.

Real-world applications:

iERS has been installed in many pump-jack applications (for oil drilling, etc.). The cycle of a pump jack is extreme; for part of the cycle the pump requires near-full torque. In the other part of the cycle, the pump jack is very lightly loaded. In this extreme application, iERS reduced average power consumed by the pump jack (over 30-minute intervals) from 23.99kW down to 19.85kW. This is a 17% reduction in consumed power. Again, this is an extreme example and is not indicative of what a typical application may save.

iERS has been installed on metal grinding equipment. A machine that was retrofitted with an iERS starter had a 75hp motor on a spindle that typically ran at about 20–30% of full load. iERS was able to reduce the energy consumed by this motor by 13–15%.

Stellar® SR55 Full-Featured Soft Starters

SR55 Soft Starter Overcurrent Protection



Customer-supplied external power-circuit isolation devices (contactors, disconnect switches, fusible disconnects, shunt-trip circuit breakers, etc.) and short-circuit protection devices (circuit breakers, fuses, etc.) are required for use with SR55 soft starters.

External Short-Circuit Protection Required for SR55											
SR55 Model Number (SR55-XXX)			017	021	027	034	040	052	065	077	096
Rated Operational Current	I_e	(A)	17	21	27	34	40	52	65	77	96
Semiconductor Fuse (class aR) #1	Type		Mersen 6,9 URD 30xx Bussmann 170M30xx Bussmann 170M31xx Bussmann 170M32xx SIBA 20 61xx								
	Rating	(A)	100	100	160	160	160	200	200	250	315
Class J High-Speed Current-Limiting Fuse #2	Rating Z1	(A)	30	45	60	70	90	110	125	150	175
Class J Time-Delay Fuse #3	Rating Z2	(A)	30	40	50	60	70	100	125	150	175
UL Listed Inverse Time-Delay Circuit Breaker #3	Rating Z3	(A)	60	60	60	60	60	150	150	250	300
Rated Conditional Short-Circuit Current	I_q	(kA)	5						10		
SR55 Model Number (SR55-XXX)			124	156	180	242	302	361	414	477	-
Rated Operational Current	I_e	(A)	124	156	180	242	302	361	414	477	-
Semiconductor Fuse (class aR) #1	Type		Mersen 6,9 URD 31xx Bussmann 170M40xx Bussmann 170M41xx Bussmann 170M42xx SIBA 20 61xx			Mersen 6,9 URD 33xx Bussmann 170M60xx Bussmann 170M61xx Bussmann 170M62xx SIBA 20 63xx					
	Rating	(A)	400	550	550	700	800	900	1000	1100	-
Class J High-Speed Current-Limiting Fuse #2	Rating Z1		250	350	400	500	600	600	n/a		-
Class J Time-Delay Fuse #3	Rating Z2	(A)	225	300	350	450	500	500	600	600	-
UL Listed Inverse Time-Delay Circuit Breaker #3	Rating Z3	(A)	350	450	500	700	800	1000	1000	1000	-
Rated Conditional Short-Circuit Current	I_q	(kA)	10			18					

- #1 Correctly selected semiconductor fuses can provide additional protection against damage to the SR55 unit (this is sometimes referred to as type 2 coordination). These semiconductor fuses are recommended to provide this increased protection.
- #2 Suitable for use in a circuit capable of delivering not more than I_q rms Symmetrical Amperes, when protected by Class J high-speed current-limiting 600V-rated fuses with a maximum trip rating of Z1 (IEC Type 1 coordination short-circuit protection).
- #3 Suitable for use in a circuit capable of delivering not more than I_q rms Symmetrical Amperes, 480 Volts maximum, when protected by Class J time delay fuses with a maximum rating of Z2, or by a circuit breaker with an interrupting rating not less than Z3 rms Symmetrical Amperes, 480 Volts maximum as in table.

SR55 Soft Starter Overload Trip

The SR55 soft starter provides motor overload protection, which can be configured through the touchscreen. Overload trip settings are determined by the Motor Current setting and the Trip Class setting. Trip class choices are class 10, class 20, and class 30. The SR55 soft starters are protected using full I2T motor overload with memory.

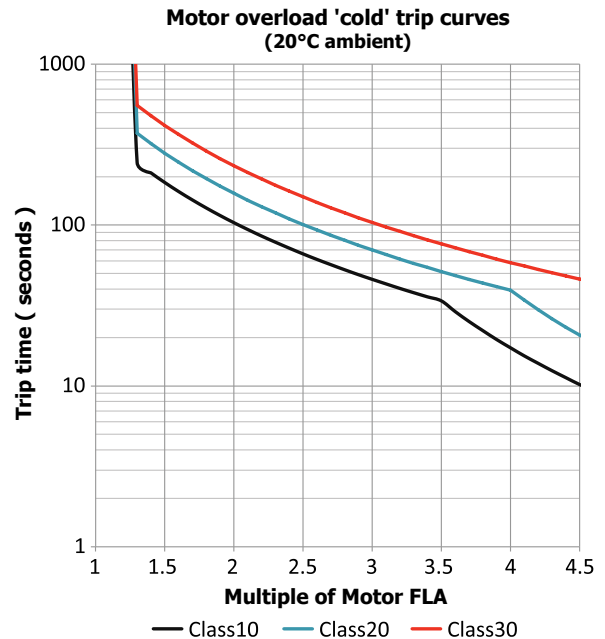

Stellar® SR55 Full-Featured Soft Starters

SR55 Soft Starter Selection

An Online Product Selection Tool is available on our website:
<https://selectors/softstarters>

SR55 Soft Starters – O/L Trip Classes 1	
Default	10
Heavy	20
Agitator	10
Compressor - Centrifugal	20
Compressor - Reciprocating	20
Compressor - Rotary Screw	20
Compressor - Rotary Vane	10
Compressor - Scroll	10
Ball mill	20
Centrifuge*	30
Bow Thruster - Zero Pitch	10
Bow Thruster - Loaded	20
Conveyor - Unloaded	10
Conveyor - Loaded	20
Crusher	30
Fan - Low Inertia < 85A	10
Fan - High Inertia > 85A	30
Feeder - screw	10
Grinder	20
Hammer mill	20
Lathe machines	10
Mills - Flour, etc.	20
Mixer - Unloaded	10
Mixer - Loaded	20
Molding Machine	10
Pelletizers	20
Plastic and textile machines	10
Press, flywheel	20
Pump - Submersible Centrifugal	10
Pump - Submersible Rotodynamic	10
Pump - Positive displacement Reciprocating	20
Pump - Positive displacement Rotary	20
Pump Jack	20
Rolling mill	20
Roots Blower	20
Saw - Band	10
Saw - Circular	20
Screen - Vibrating	20
Shredder	30
Transformers, voltage regulators	10
Tumblers	20
Wood chipper	30

SR55 Soft Starter Selection Steps

- 1 Determine the required trip class based on the motor load and required start time. See examples to the left (refer to the definitions of Class 10, 20, and 30 Trip Curves on page tSST-26).
- 2 Below, select the row with the correct motor full load amps. Then select the correct SR55 soft starter to the right based on Trip Class (longer start times require a larger starter). Notice that there are different Motor Amps columns for starters wired In-Line (most common) and In-Delta. Select the applicable SR55 part number based on the required Trip Class, motor HP, and connection type.



Derating is necessary if your application requires multiple starts per hour. Refer to page tSST-29, “SR55 Increased Starts per Hour – Derating.”

SR55 Soft Starters – Selection Table 2 (per IEC 60947-4-1:2009 Table G.1)												
Motor Size										Soft Starter Size		
In-Line Connection					In-Delta Connection *					Application Trip Class		
I (A)	HP @				I (A)	HP @				Class 10	Class 20	Class 30
	200V	208V	230V	460V		200V	208V	230V	460V			
17	3	5	5	10	29	7.5	7.5	10	20	SR55-017	SR55-021	SR55-027
21	5	5	5	15	36	10	10	10	25	SR55-021	SR55-027	SR55-034
27	7.5	7.5	7.5	20	47	10	15	15	30	SR55-027	SR55-034	SR55-040
34	10	10	10	25	59	15	15	20	40	SR55-034	SR55-040	SR55-052
40	10	10	10	30	69	20	20	25	50	SR55-040	SR55-052	SR55-065
52	15	15	15	40	90	25	30	30	60	SR55-052	SR55-065	SR55-077
65	20	20	20	50	113	30	30	40	75	SR55-065	SR55-077	SR55-096
77	20	25	25	60	133	40	40	50	100	SR55-077	SR55-096	SR55-124
96	30	30	30	75	166	50	50	60	125	SR55-096	SR55-124	SR55-156
124	40	40	40	100	215	60	75	75	150	SR55-124	SR55-156	SR55-180
156	50	50	60	125	270	75	75	100	200	SR55-156	SR55-180	SR55-242
180	60	60	60	150	312	100	100	125	250	SR55-180	SR55-242	SR55-302
242	75	75	75	200	419	150	150	150	300	SR55-242	SR55-302	SR55-361
302	100	100	100	250	523	150	150	200	450	SR55-302	SR55-361	SR55-414
361	125	125	150	300	625	200	200	250	500	SR55-361	SR55-414	SR55-477
414	150	150	150	350	717	250	250	250	500	SR55-414	SR55-477	n/a
477	150	150	150	400	826	250	300	300	600	SR55-477	n/a	n/a

* For In-Delta connections, all six motor wires must be available for connection, and it is critical to exactly follow the In-Delta wiring diagram in the SR55 User Manual or Quick-start Guide. Nine-lead motors CANNOT be connected in the delta. The Soft Starter will only sense the Phase Current, which is about 58% of the Line Current.

* For In-Delta connections, a main contactor that is controlled by the Run relay of the SR55 must be used in the incoming power circuit for isolation. Circuit breaker isolation alone is not sufficient.

* iERS energy optimizing feature is not available for In-Delta connections.

* Size centrifuge starter at I(A)
 = (motor FLA x 2.3). Trip Class 30.

Stellar® SR55 Full-Featured Soft Starters

SR55 Index Ratings (per IEC 60947-4-2)

SR55 Index Ratings *		
Model Number	I _e (A)	Standard Operation AC-53a; X-Tx; F-S
SR55-017 to SR55-180	17 to 195	AC-53a: 3.5-17; 90-5
SR55-242 to SR55-477	242 to 500	AC-53a: 3.5-17; 90-3

* Index ratings AC-53a and AC-53b are specified by IEC standard # 60947-4-2. IEC Index Ratings are comprised of Rated Operational Current (I_e), Utilization Category, Overload Current Profile (X-Tx), and Duty Cycle (F-S) or OFF-time.

Index Rating Example – Standard Operation (AC-53a Utilization Category per IEC 60947-4-2)

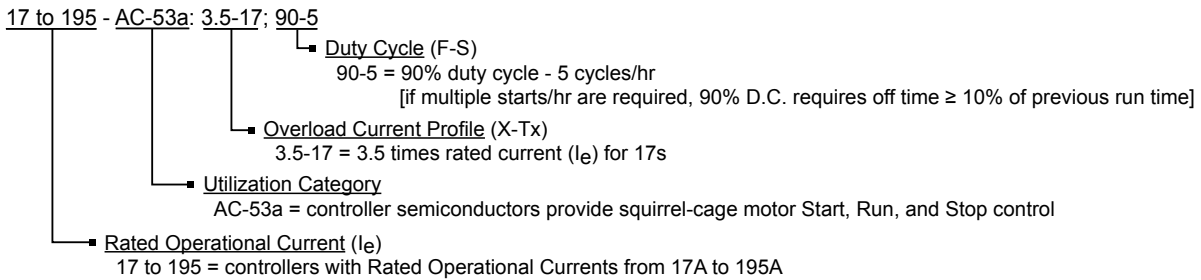

Standard Overload Current Profile and Duty Cycle

The SR55 has been designed for a specific Overload Current Profile and Duty Cycle as shown above in the SR55 Index Ratings.

The Overload Current Profile is expressed by two symbols, X and Tx.

X denotes the overload current as a multiple of I_e and represents the maximum value of operating current due to starting, operating, or maneuvering under overload conditions.

For example, X = 3.5 means that the maximum overload start current allowed is 3.5 times FLC.

Tx denotes the duration of the controlled overload currents during starting, stopping, operating, or maneuvering.

For example, Tx = 17 means that the maximum allowed overload current is permitted for up to 17 seconds only.

The Duty Cycle is expressed by two symbols, F and S which describe the duty and also set the time that must be allowed for cooling.

F is the ratio of the on-load period to the total period expressed as a percentage.

For example, F = 90 means that the soft starter is ON for 90% of the time and then OFF for 10% of the time between each start.

If there are not multiple starts per hour, then the Duty Cycle is continuous.

S is the number of starts or operating cycles per hour.

For example, S = 5 means that the soft starter is capable of 5 equally spaced starts per hour.

These characteristics are summarized in Figure 1.

Figure 1: Standard Overload Current Profiles and Duty Cycles					
Model	Rated Current (A)	Class 10 O/L Multiple (X)	Class 10 O/L Time (Tx)	Starts / Hour (S)	Duty (F)
SR55-017	017	3.5	17	5	90%
SR55-021	021				
SR55-027	027				
SR55-034	034				
SR55-040	040				
SR55-052	052				
SR55-065	065				
SR55-077	077				
SR55-096	096				
SR55-124	124				
SR55-156	156				
SR55-180	180				
SR55-242	242			3	
SR55-302	302				
SR55-361	361				
SR55-414	414				
SR55-477	477				

Stellar® SR55 Full-Featured Soft Starters

SR55 Increased Starts per Hour – Derating

If more than the standard number of starts/hour is required, the SR55 must be derated. To derate for more starts/hour, the motor full load current must be less than the SR55 current. The relationship between the SR55 deration and the starts/hour is given below in Figure 2 and the two examples that follow. This assumes that the SR55 is still operating at the same duty (F) as given in Figure 1.

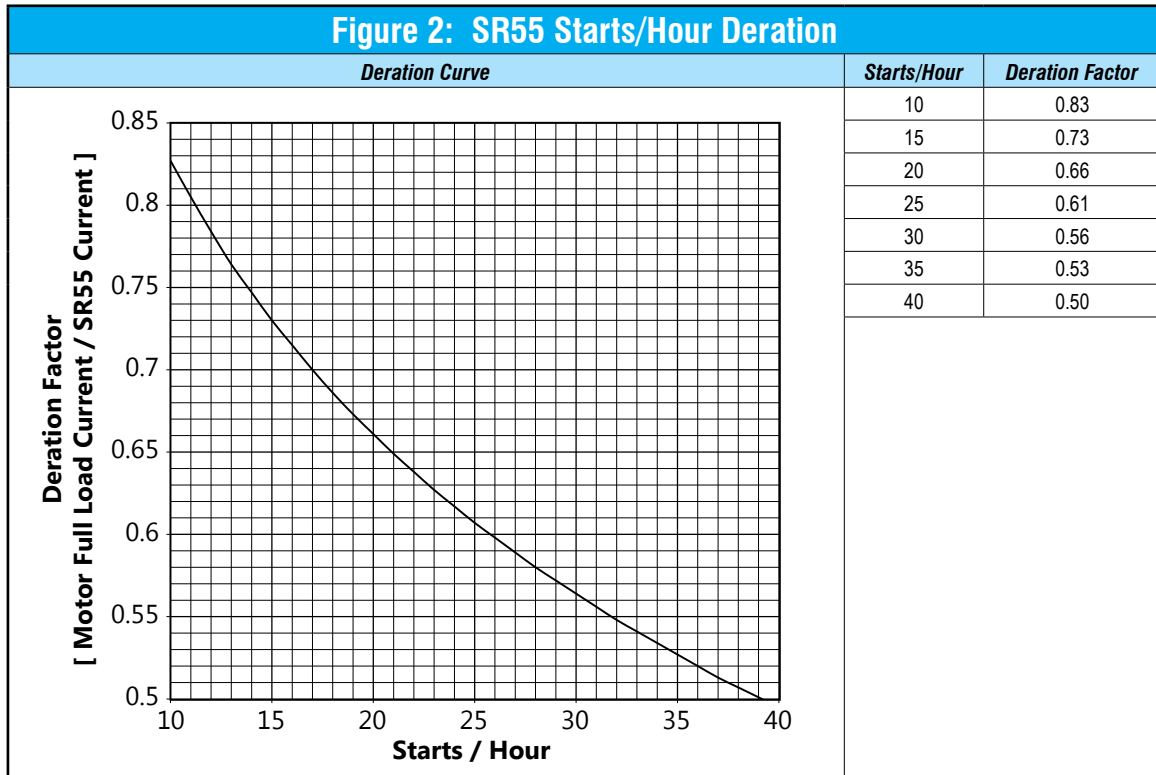

Deration Factor = $(138 - (24 \cdot \ln(\text{starts/hr}))) / 100$
 [where $\ln(\text{starts/hr})$ is the natural log of the # of starts/hour]
 Example: Deration Factor for 10 starts/hr = $(138 - (24 \cdot \ln(10))) / 100 = 0.83$

Example 1: SR55 Selection and Configuration		
Step	SR55 Selection	
1	Application	Loaded Conveyor
2	Trip Class	20
3	Duty	90%
4	In-Line or In-Delta	In-Line
5	Ambient Temperature	40°C
6	Altitude	1000m
7	Full Motor Load Current	80A
8	Current Limit	4 x 80A = 320A
9	Number of Starts/Hour	10
10	Deration Factor (from Fig.2)	0.83
11	SR55 (A) = Motor FLC / Deration Factor	96A
12	Determine SR55 from Sizing Guide	SR55-096
Step	SR55 Configuration	
1	Select Application	(Auto Setup)
2	Leave Motor Current 100A (maximum)	(Auto Setup)
3	Set Start Current Limit to 320A (400% of motor FLC)	(Start Current Limit)
4	Set Overload Level to 88A (110% of motor FLC)	(Overload Settings)
Step	SR55 Alternative Configuration	
1	Set Application	(Auto Setup)
2	Set Motor Current to 80A	(Auto Setup)
3	Warm Trip Time will be reduced to Trip Class 10 value	(320A for 13s)

Example 2: SR55 Selection and Configuration		
Step	SR55 Selection	
1	Application	Agitator
2	Trip Class	10
3	Duty	90%
4	In-Line or In-Delta	In-Line
5	Ambient Temperature	40°C
6	Altitude	1000m
7	Full Motor Load Current	66A
8	Current Limit	3.5 x 66A = 231A
9	Number of Starts/Hour	20
10	Deration Factor (from Fig.2)	0.66
11	SR55 (A) = Motor FLC / Deration Factor	100A
12	Determine SR55 from Sizing Guide	SR55-124
Step	SR55 Configuration	
1	Select Application	(Auto Setup)
2	Leave Motor Current 100A (maximum)	(Auto Setup)
3	Set Start Current Limit to 231A (350% of motor FLC)	(Start Current Limit)
4	Set Overload Level to 72A (110% of motor FLC)	(Overload Settings)
Step	SR55 Alternative Configuration	
1	Set Application	(Auto Setup)
2	Set Motor Current to 66A	(Auto Setup)
3	Set Trip Class to 30	(Overload Settings)
4	Warm Trip Time will be reduced to Trip Class 10 value	(231A for 17s)

Stellar[®] SR55 Full-Featured Soft Starters

SR55 Soft Starter Dimensions

Dimensions = in [mm]

See our website: _____ for complete engineering drawings.



The addition of optional finger guards to size 1 and size 2 SR55 soft starters adds approximately 14mm [0.5in] to the soft starter vertical dimension, but does NOT change the clearance distance.

Frame Size 1: SR55-017 to SR55-027

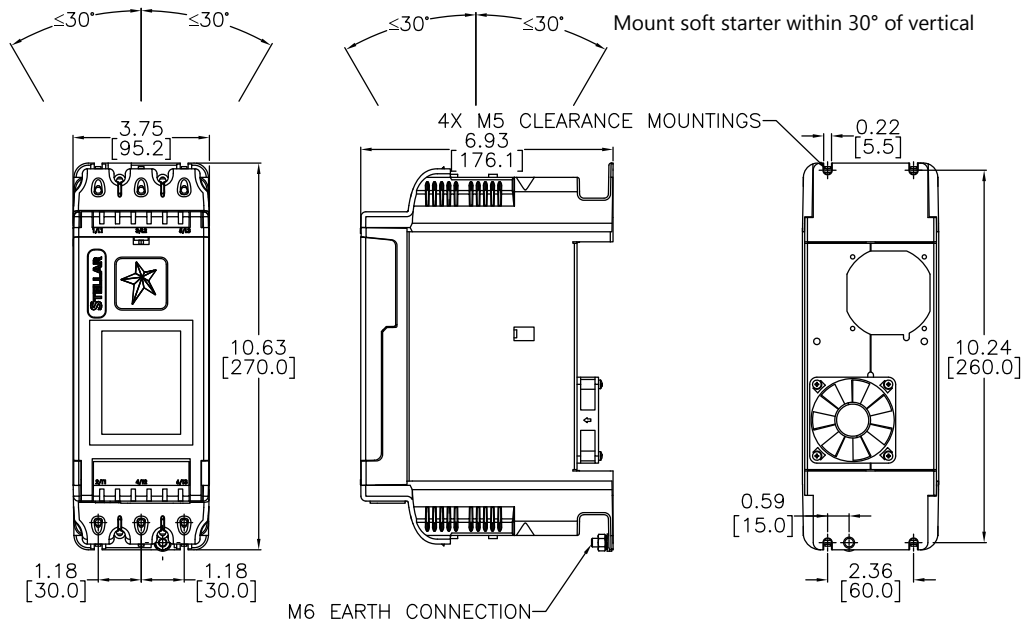

Frame Size 1: SR55-034 to SR55-096

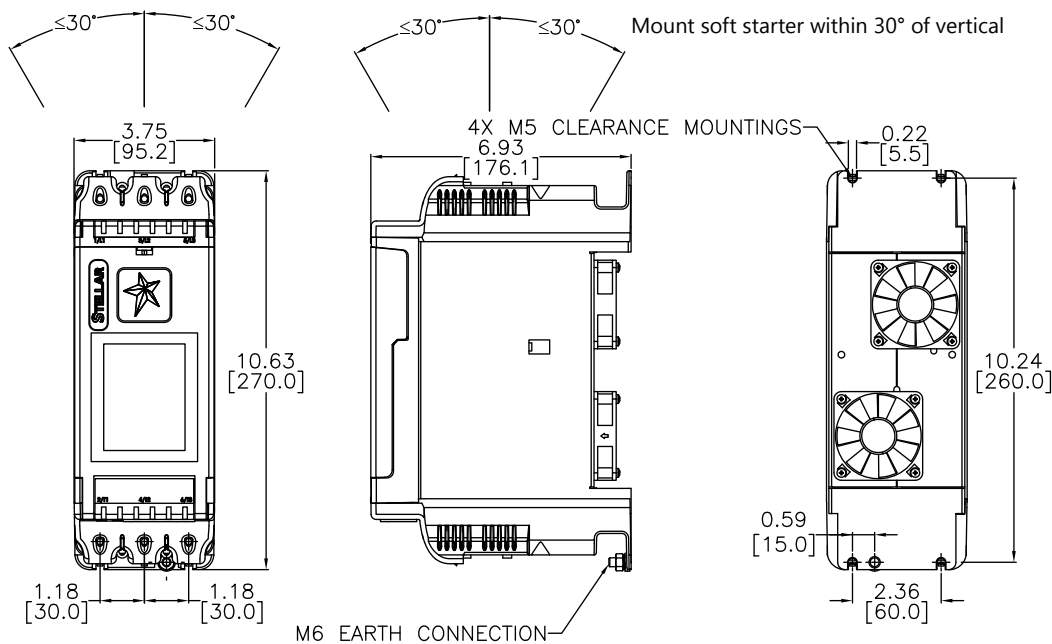

Stellar[®] SR55 Full-Featured Soft Starters

SR55 Soft Starter Dimensions

Dimensions = in [mm]

See our website: _____ for complete engineering drawings.



The addition of optional finger guards to size 1 and size 2 SR55 soft starters adds approximately 14mm [0.5in] to the soft starter vertical dimension, but does NOT change the clearance distance.

Frame Size 2: SR55-124 to SR55-180

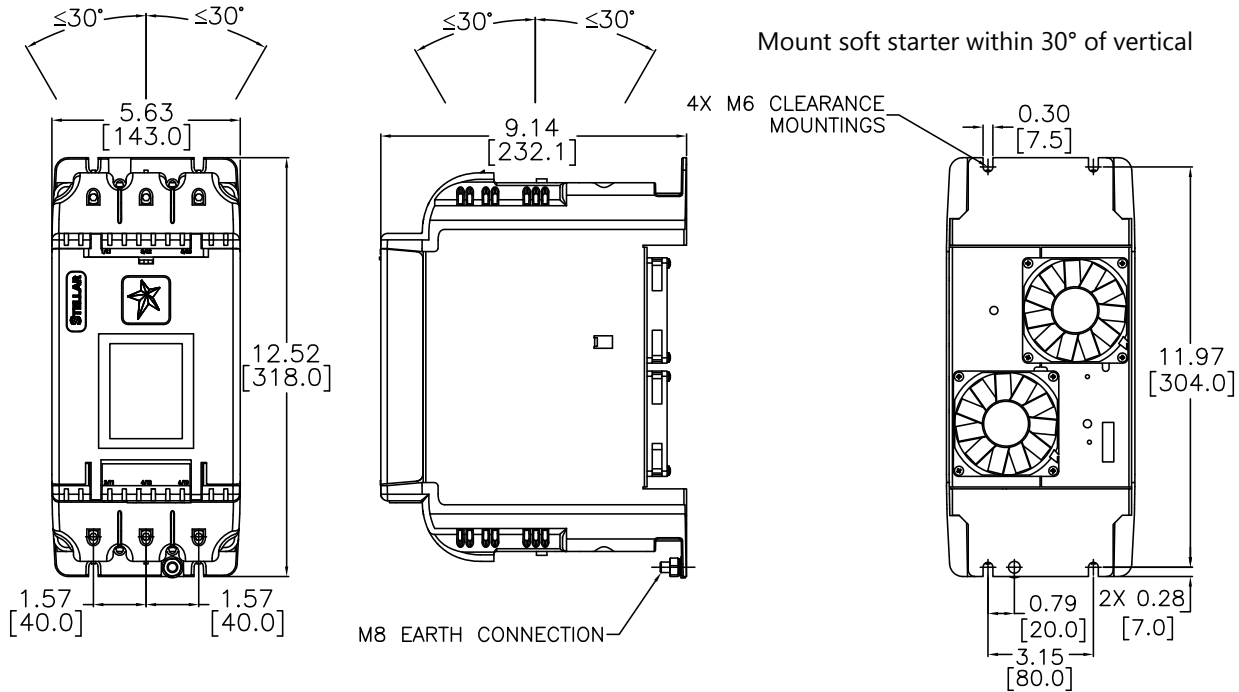

Frame Size 3: SR55-242 to SR55-361

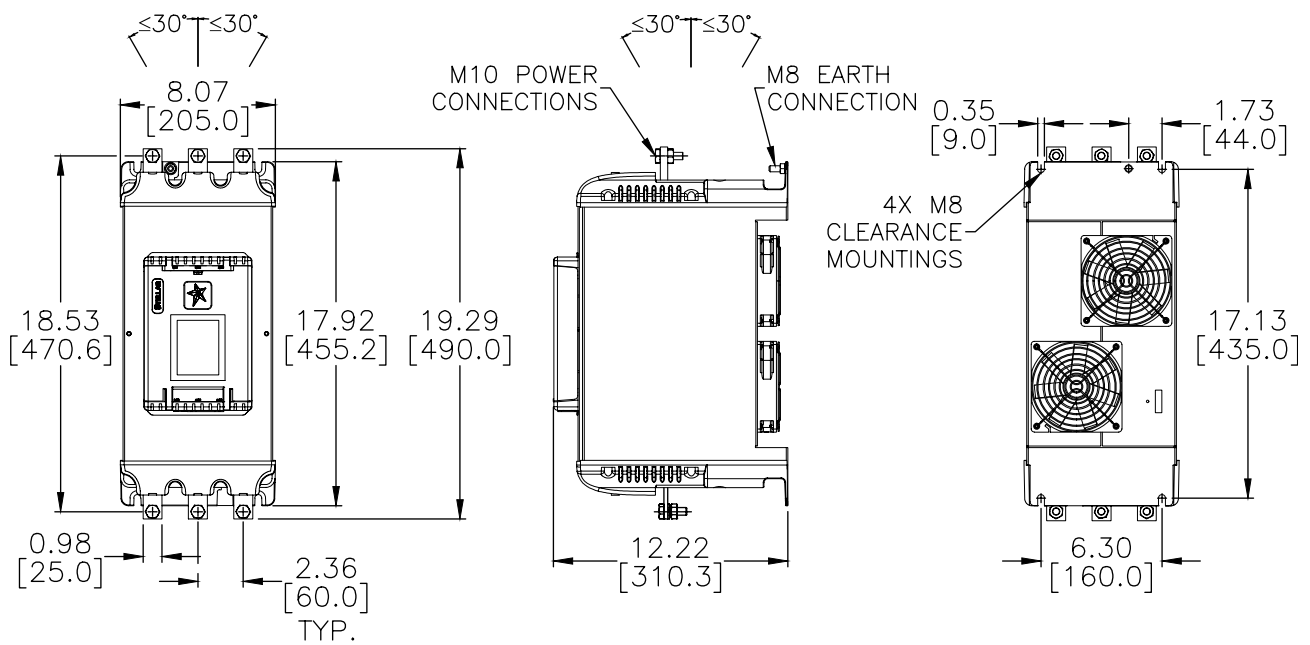

Stellar[®] SR55 Full-Featured Soft Starters

SR55 Soft Starter Dimensions

Dimensions = in [mm]

See our website: _____ for complete engineering drawings.

Frame Size 3: SR55-414 to SR55-477

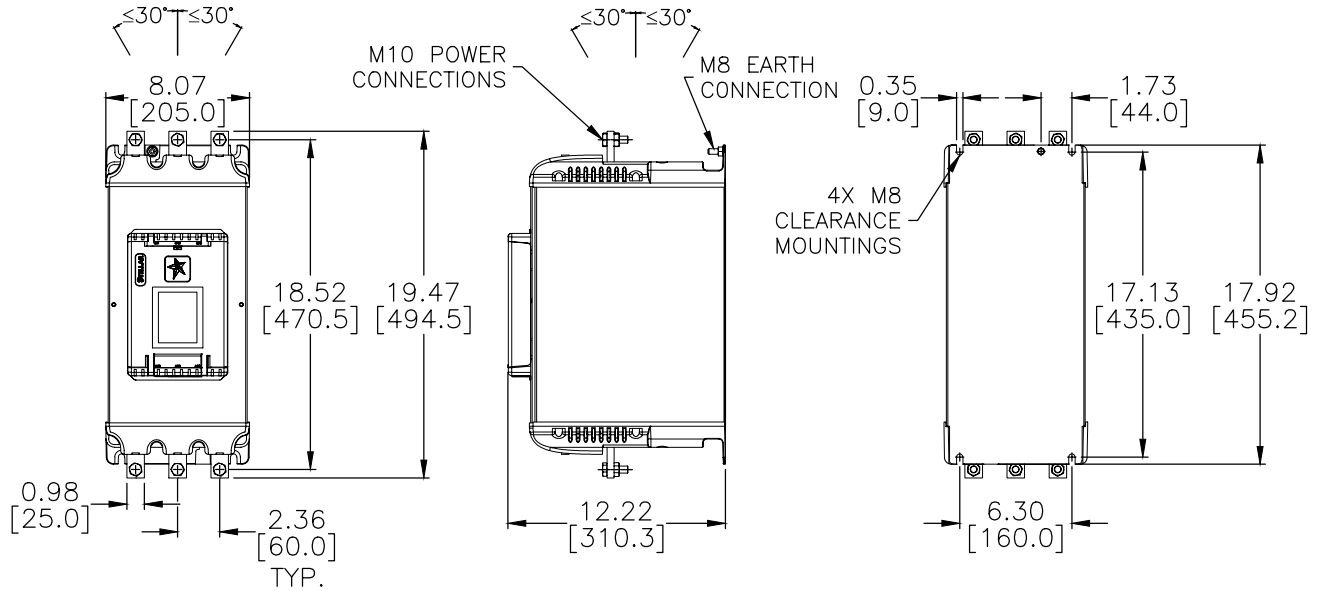

Ventilation for Enclosures

SR55 Minimum Clearance Distances * (in [mm])					
SR55 Soft Starter Model	Top	Bottom	Left	Right	Front
Size 1: SR55-017 to SR55-096	3 [75]			1 [25]	
Size 2: SR55-124 to SR55-180	3.9 [100]		1.6 [40]		1 [25]
Size 3: SR55-242 to SR55-477	4.9 [125]		2.4 [60]		1 [25]

* For heat dissipation, the SR55 must not be mounted any closer to another object than these distances.



The addition of optional finger guards to size 1 and size 2 SR55 soft starters adds approximately 14mm [0.5in] to the soft starter vertical dimension, but does NOT change the clearance distance.



When fitting SR55 into an enclosure, ventilation must be provided if the heat output of the unit is greater than the enclosure will dissipate. Use the formula at right to determine the fan requirement. An allowance has been incorporated into the formula so that the figure for Q is the air delivery in the fan suppliers data.

The power dissipation of the thyristors are at their peak when the SR55 is in energy saving mode (iERS), therefore causing the most heat generated from the starter. Heat dissipated can be approximated with the formula:
 Watts (SR55) = 1/2 x (SR55 current rating) x 3

$$Q = (4xWt) / (T_{max} - T_{amb})$$

Q = Volume of air (cubic meters per hour - m³/h)

Wt = Heat produced by the unit and all other heat sources within the enclosure (Watts)

T_{max} = Maximum permissible temperature within the enclosure (50°C for a fully rated SR55)

T_{amb} = Temperature of the air entering the enclosure (°C)
 (If you prefer to work in CFM, substitute °F for °C. Q is now in CFM)

Stellar® SR55 Full-Featured Soft Starters

SR55 Soft Starter Optional Accessories

EtherNet/IP Module

The EtherNet/IP communication module is intended to be installed in the SR55 option slot, and allows the SR55 to be connected to an EtherNet/IP network. The interface offers the following functionality:

- CIP Parameter Object Support
- Supports Explicit and Implicit Messaging

SR55-CM-ENETIP2

- 7 Input Words from the network master to SR55
- 5 Output Words from SR55 to the network master

SR55-CM-ENETIP

- 2 Input Words from the network master to SR55
- 2 Output Words from SR55 to the network master

Modbus TCP Module

Allows an SR55 soft starter to be connected to a Modbus TCP network using TCP/IP protocol.

The communication module supports 4 simultaneous (master) connections and allows access to all user parameters.



EtherNet/IP Module: SR55-CM-ENETIP(2)



Modbus TCP Module: SR55-CM-MODTCP

Finger Guards

For SR55 soft starter power-circuit line and load side terminals; provides IP20 protection for soft starter sizes SR55-180 and below (frame sizes 1 and 2).

Remote Touchscreen

Allows remote monitoring, configuration, and control of SR55 soft starters. Since the touchscreen is a master RS-485 device, it can control multiple SR55 soft starters. Includes a 3m Ethernet cable and an SR55-RJ45-RJ12 adapter.



Remote Touchscreen: SR55-KPD-REM



Modbus Serial Splitter: SR55-SPLT



Finger Guards: SR55-FG-1 & SR55-FG-2



RJ45 to RJ12 Adapter: SR55-RJ45-RJ12



USB Flash Drive: USB-FLASH

Modbus Serial Splitter

Includes an SR55-RJ45-RJ12 adapter cable. Allows a Modbus network over RS-485 to be constructed as plug-and-play with standard Ethernet cables. Customer must provide cable between RS-485 master and the first splitter. Can only be used with one master at a time on the network, e.g. Remote Touchscreen, PLC, or HMI. Splitter includes (3) female RJ45 ports.

RJ45 to RJ12 Adapter

Allows connection of the Remote Touchscreen, Modbus Splitter, or other Modbus master to the RJ12 port on top of the SR55 soft starter.

Adapter has a male RJ12 connector and a female RJ45 connector (allows use of standard Ethernet cables).

USB Flash Drive

4GB USB Flash drive. Recommended for SR55 firmware updates and data logging.

NOTE: Other flash drives may not work with SR55. USB-FLASH has been successfully tested with SR55.

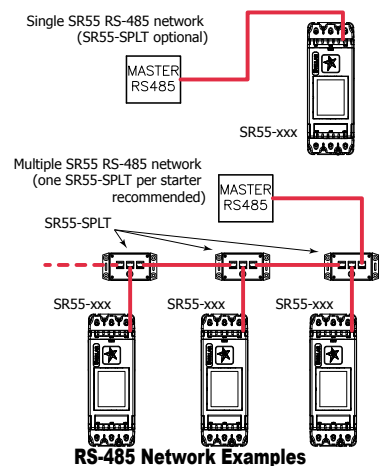

RS-485 Network Examples

SR55 Optional Accessories

Part Number	Price	Description	For SR55 Models
SR55-CM-ENETIP2		EtherNet/IP communication module, optional, for Stellar SR55 series soft starters, dual RJ45 communication ports, complete EtherNet/IP adapter, TCP/IP socket interface, CIP parameter object support, implicit and explicit messaging, transformer isolated Ethernet interface, 10/100 Mbps full duplex.	all
SR55-CM-ENETIP		EtherNet/IP communication module, optional, for Stellar SR55 series soft starters, dual RJ45 communication ports, complete EtherNet/IP adapter, TCP/IP socket interface, CIP parameter object support, implicit and explicit messaging, transformer isolated Ethernet interface, 10/100 Mbps full duplex.	all
SR55-CM-MODTCP		Modbus TCP communication module, optional, for Stellar SR55 series soft starters, dual RJ45 communication ports, complete Modbus TCP server, up to 256 bytes of I/O data in each direction, transformer isolated interface, 100 Mbps full duplex, TCP/IP socket interface, supports 4 simultaneous (master) connections.	all
SR55-FG-1		Finger guards, replacement, for size 1 Stellar SR55 series soft starter power terminals. Provides IP20 protection rating. Package of 2.	017 thru 096
SR55-FG-2		Finger guards, replacement, for size 2 Stellar SR55 series soft starter power terminals, Provides IP20 protection rating. Package of 2.	124 thru 180
SR55-KPD-REM		Touchscreen, optional remote, for Stellar SR55 series soft starters. Used to remotely monitor, configure, and control SR55 series units without opening enclosures. Rated for NEMA 4/4X enclosures, no external power wiring required. Includes 3m RJ45 cable and SR55-RJ45-RJ12 adapter.	all
SR55-SPLT		Serial Modbus communication splitter, optional, for Stellar SR55 series soft starters. Used for creating a Modbus network with multiple SR55 series soft starters. Uses 3 serial RJ45 connectors for upstream/downstream connectivity and connection to the starter.	all
SR55-RJ45-RJ12		RJ45 female to RJ12 male adapter, optional, for Stellar SR55 series soft starters.	all
USB-FLASH		USB Flash drive, SanDisk, 4GB (SanDisk P/N SDCZ50-004G-A46).	all

Stellar® SR55 Full-Featured Soft Starters

SR55 Soft Starter Accessory Dimensions

Dimensions = in [mm]

SR55-KPD-REM Remote Touchscreen Dimensions & Panel Mounting Cut-Out Dimensions

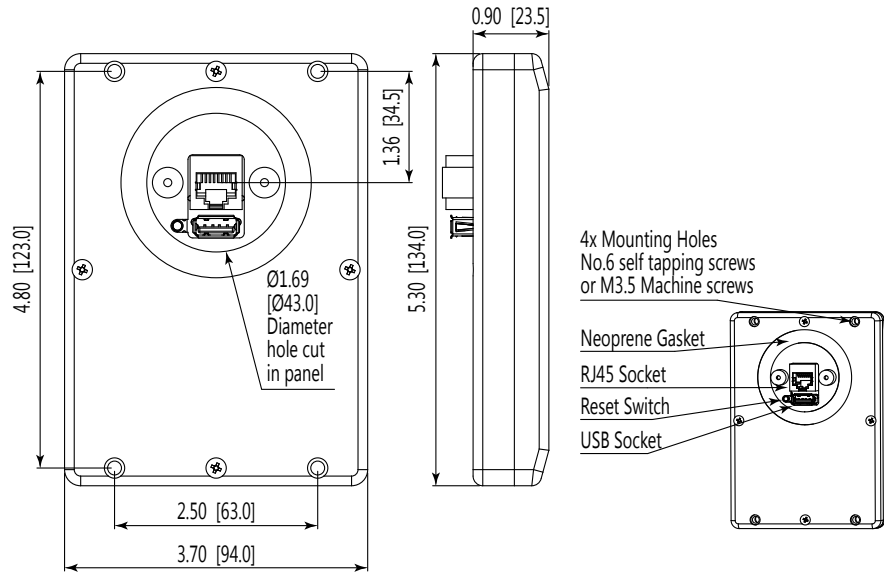

SR55 Soft Starter Replacement Parts



Replacement Fan: **SR55-FAN-2**



Replacement Fan: **SR55-FAN-3**



Replacement Fan: **SR55-FAN-6**



Replacement Fan: **SR55-FAN-7**



Replacement Fan: **SR55-FAN-8**

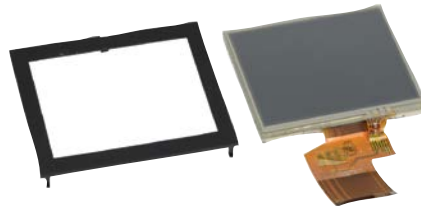

Replacement Touchscreen: **SR55-KPD**

SR55-FAN-6 Fan Replacement Quantity Flowchart

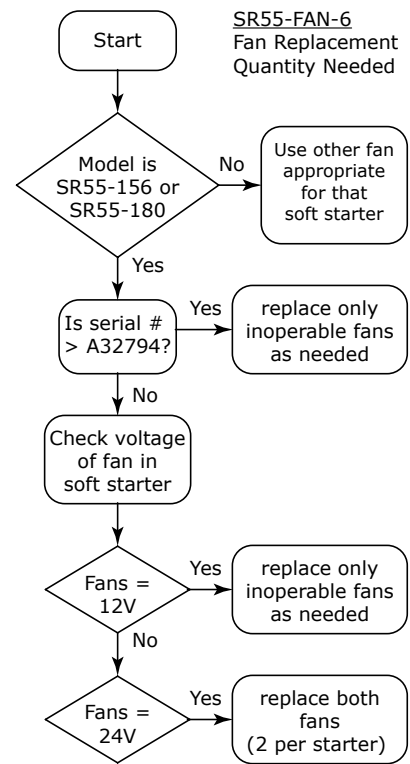

SR55 Spare/Replacement Parts *

Part Number	Price	Description	For SR55 Models
SR55-FAN-2 **		Cooling fan, replacement, for size 1 Stellar SR55 series soft starters, 60 x 60 x 15 mm	017 thru 096
SR55-FAN-3 **		Cooling fan, replacement, for size 2 Stellar SR55 series soft starters, 80 x 80 x 15 mm	124
SR55-FAN-6 ***		Cooling fan, replacement, for size 2 Stellar SR55 series soft starters, 80 x 80 x 20 mm	156 thru 180
SR55-FAN-7 **		Cooling fan, replacement, for size 3 Stellar SR55 series soft starters, 120 x 120 x 25 mm	242 thru 361
SR55-FAN-8 **		Cooling fan, replacement, for size 3 Stellar SR55 series soft starters, 171 x 151 x 151 mm	414 thru 477
SR55-KPD		Touchscreen, replacement, for Stellar SR55 series soft starters	all

* These items are exact replacements for the comparable part that is originally installed on the applicable SR55.

** These fans include wiring connectors.

*** SR55-FAN-6 12VDC fan kits fit SR55-156 and SR55-180 soft starters. Some early models of these starters were equipped with 24VDC fans, and two SR55-FAN-6 kits are required for those particular models since both 24VDC fans require replacement. The 12VDC fan kits include wiring connectors and a resistor, which is for use only with the 24VDC soft starters. Refer to the Fan Replacement Quantity flowchart above to determine how many fan kits you need.