

## Compact Slide Actuators - Generation 2

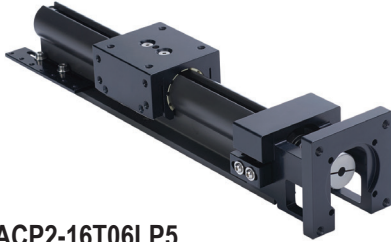

**LACP2-16T06LP5**

### Description

Self-contained linear actuator designed for light loads in harsh or wet conditions in a very small package. The base is a single piece design with integrated slide surfaces, and is hard anodized all over.

Generation 2 actuators have a reduced part count for more reliable operation, integral wireway through the body and more robust motor mount that fits both NEMA 17 and 23 motors.

### Features

- Compact design
- Replacement components available
- Ready for NEMA 17 motor (NEMA 23 motor requires new coupling)
- End-of-travel switch mounts
- AISI 6061-T6 Aluminum Alloy base, Hard Anodized on all surfaces to a depth of 0.0005 to 0.0015"
- AISI 303 Stainless Steel Lead Screw

### Applications

- Space-limiting applications
- Harsh or wet environments
- Light loads
- Speeds up to 20 inches per second

Compact Slide Actuator Specifications									
Part Number	Price	Drive Type	Drive Pitch	Drive Screw Efficiency (%)	Payload Inertia Factor (in <sup>2</sup> )	Constant System Inertia (lbm-in <sup>2</sup> )	Travel	Weight (lb)	Fits Motor
<a href="#">LACP2-16T06LP5</a>	8.00	Lead screw	0.5 in	52	0.0063	0.016	6in	1.8	NEMA 17
<a href="#">LACP2-16T12LP5</a>	6.00					0.017	12in	2.3	
<a href="#">LACP2-16T24LP5</a>	6.00					0.020	24in	3.5	
<a href="#">LACP2-16T36LP5</a>	8.00					0.024	36in	4.5	
<a href="#">LACP2-16T06L1</a>	8.00		1in	44	0.025	0.022	6in	1.8	
<a href="#">LACP2-16T12L1</a>	6.00					0.023	12in	2.3	
<a href="#">LACP2-16T24L1</a>	6.00					0.026	24in	3.5	
<a href="#">LACP2-16T36L1</a>	8.00					0.030	36in	4.5	

### System Inertia Calculation:

- To calculate the inertia reflected to the motor in a particular actuator, multiply the carriage payload by the payload inertia factor and then add the constant system inertia value for that actuator. The constant system inertia value for each system includes the inertia of the shaft coupler, carriage, and lead/ball screw.
- The payload must be in units of lb<sub>m</sub>.

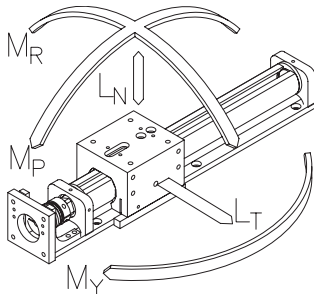

Load rating diagram

Compact Slide Actuator Load/Moment Ratings							
Part Number	Actuator Thrust	Load (lb)*			Moment (lb-in)**		
		Normal – LN		Transverse	Roll	Pitch	Yaw
		Down	Up	LT	MR	MP	MY
<a href="#">LACP2-16TxxLP5</a>	51	125	60	125	12	15	33
<a href="#">LACP2-16TxxL1</a>	28	125	60	125	12	15	33

\* 30lb is the recommended maximum load capacity if the carriage is not externally supported against rolling. The higher load capacities are possible if the carriage is externally supported.

\*\* It is recommended that offset loads be located 5 inches or less from the center of the carriage. When the loads are offset at greater distances, the carriage can vibrate during travel.

## Compact Slide Actuators - Generation 2

Dimensions (in [mm])

PART NUMBER	A	B (TRAVEL)
LACP2-16T06LP5	11.57 [293.8]	6.40 [162.6]
LACP2-16T12LP5	17.57 [446.2]	12.40 [315.0]
LACP2-16T24LP5	29.57 [751.0]	24.40 [619.8]
LACP2-16T36LP5	41.57 [1055.8]	36.40 [924.6]
LACP2-16T06L1	11.57 [293.8]	6.40 [162.6]
LACP2-16T12L1	17.57 [446.2]	12.40 [315.0]
LACP2-16T24L1	29.57 [751.0]	24.40 [619.8]
LACP2-16T36L1	41.57 [1055.8]	36.40 [924.6]

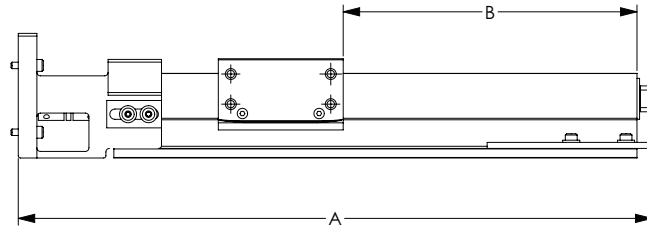
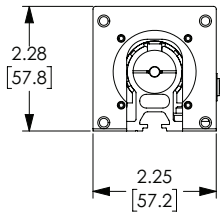
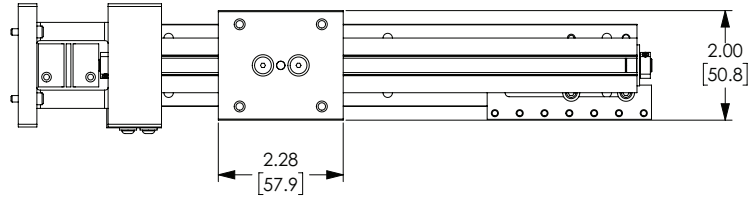

LACP2-16TxxLxx

See our website [\\_\\_\\_\\_\\_](#) for complete Engineering drawings.

### Accessories

Compact Slide Actuator Accessories			
Part Number	Price	Description	Weight (lb)
<a href="#">LAVLACC-003*</a>		SureMotion motor adapter, NEMA 23 frame. For use with LAVL2-60 series actuators. 1/4 inch x 5 mm coupler included.	1.0
<a href="#">LACPACC-0021</a>		SureMotion repair kit, for use with LACP-16TxxLP5 actuators. Nut, bushings, end bearings and oil syringe included.	0.5
<a href="#">LACPACC-0031</a>		SureMotion repair kit, for use with LACP-16TxxL1 actuators. Nut, bushings, end bearings and oil syringe included.	0.5
<a href="#">LACPACC-004</a>		SureMotion mounting plate, XY type. For use with LACP2-16 series actuators.	0.5
<a href="#">LACPACC-005</a>		SureMotion mounting plate, XY type. For use with LACP2-16 and LARSB1 series actuators.	0.5
<a href="#">LACPACC-0062</a>		SureMotion repair kit, for use with LACP2-16TxxLP5 actuators. Nut, bushings, end bearings and oil syringe included.	1.0
<a href="#">LACPACC-0072</a>		SureMotion repair kit, for use with LACP2-16TxxL1 actuators. Nut, bushings, end bearings and oil syringe included.	1.0

\* Use the coupling and motor mount screws from this kit to adapt any LACP2 actuator assembly to accept a NEMA 23 motor.

<sup>1</sup> These repair kits contain parts to rebuild Generation 1 (LACP series) actuator assemblies.

<sup>2</sup> These repair kits contain parts to rebuild current Generation 2 (LACP2 series) actuator assemblies.



LAVLACC-003



LACPACC-002(003)



LACPACC-004(005)

Some accessories not shown see [\\_\\_\\_\\_\\_](#) for additional product photos.

# Linear Motion Slides and Components to Create up to 3 Axes of Motion

SureMotion linear slide actuators easily mate to SureStep motors, SureServo motors and other NEMA motors. Everything you need to mount your SureStep motor is included!

SureMotion linear actuators provide high performance linear motion. Available in lead screw or ball screw controlled versions. Coupling and hardware to mount small NEMA frame and SureServo motors are available as well as hardware to attach units together to create motion in 2 or 3 axes of movement.

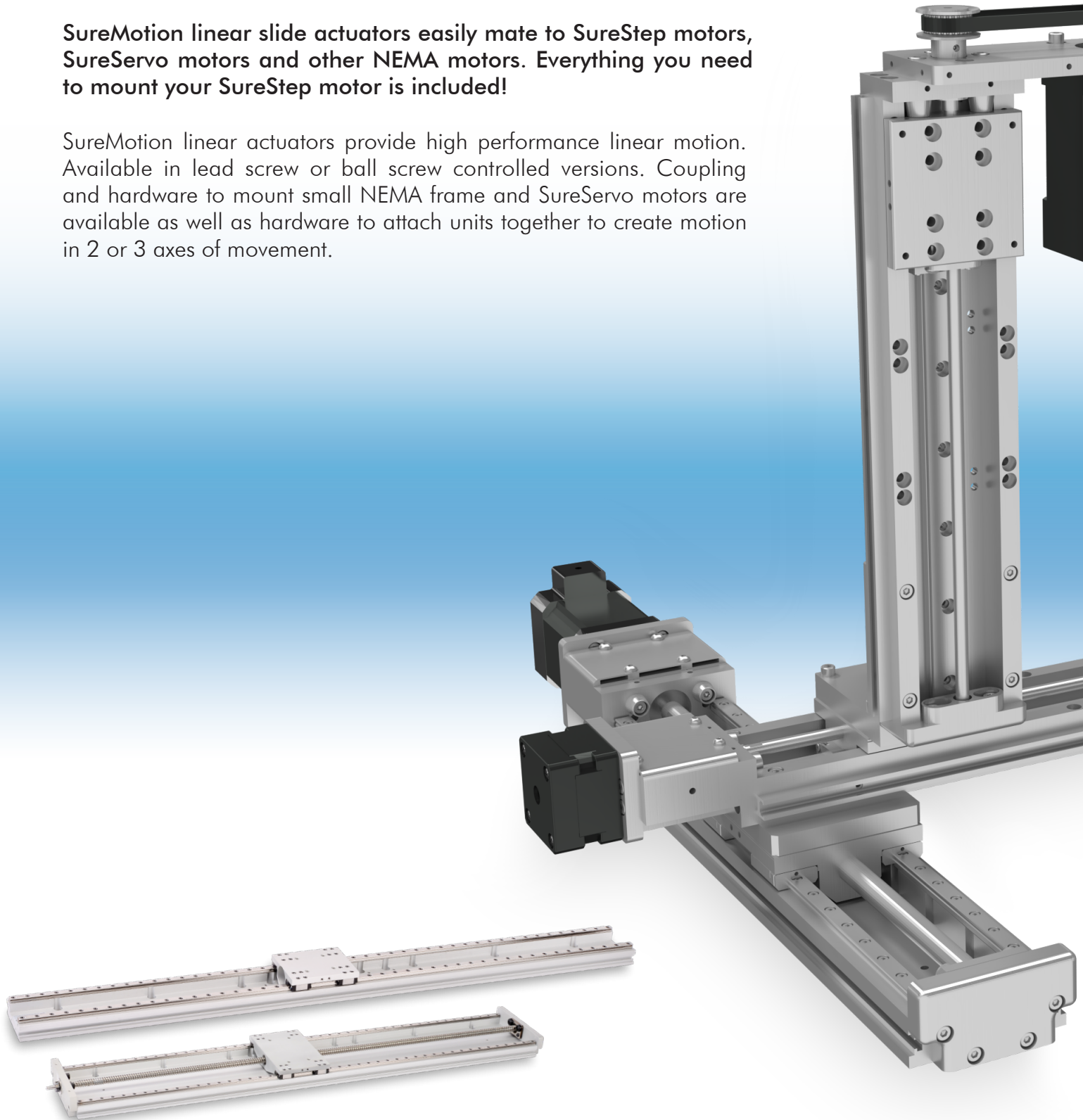

# Sure motion

**LAHP units can be attached to each other to provide up to 3 axes of motion and from 52mm to 910mm of travel.**

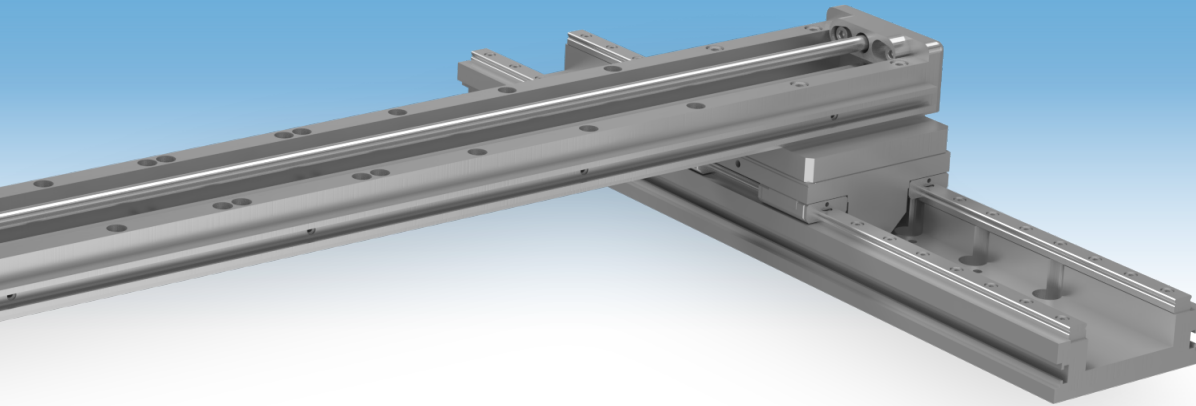
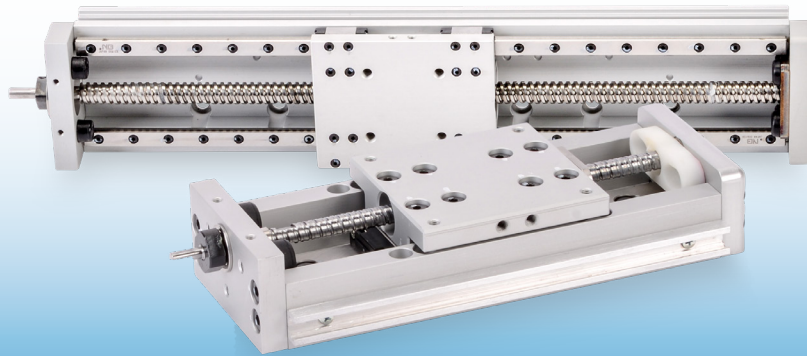

**18 models, with travels from 6 to 36 inches**

**Ready to mount NEMA 17, 23 or 34 motors**

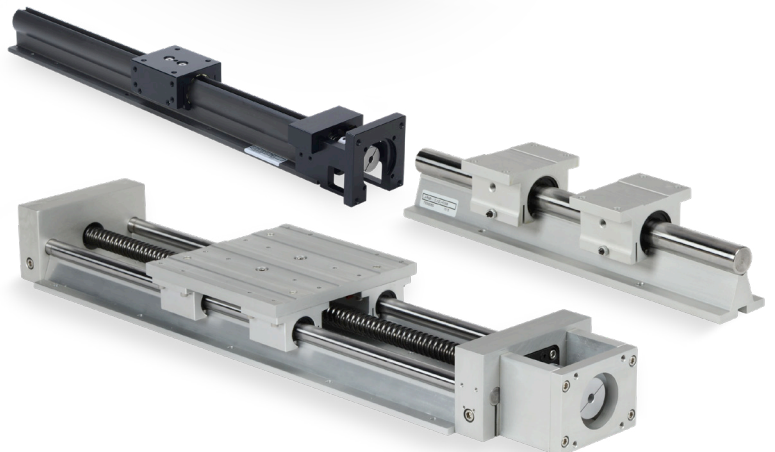

## Product Overview

### Actuator Overview

SureMotion linear motion offers both motor-ready actuator assemblies, and a versatile assortment of sliding components and accessories to provide a wide variety of motion control solutions.

#### Linear Slide Actuator Comparisons

Actuator Series Comparisons						
Actuator Series	Actuator Type	Drive Type	Max Load Capacity (lb)	Max Speed (in/s)	Travel (in)	Relative Price
LARSD2	Twin Round Shaft	Ball Screw	920	6	12, 24	\$\$\$\$
LACP2	Compact Slide	Lead Screw	125	20	6, 12, 24, 36	\$\$
LAVL2	Value Slide	Lead Screw	110	15	6, 12, 18, 24	\$

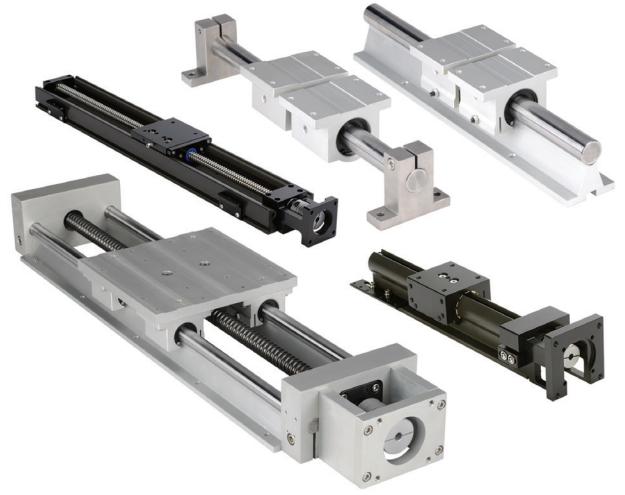

#### Available Multi-Axis Configurations

##### X-Y Axis Configurations

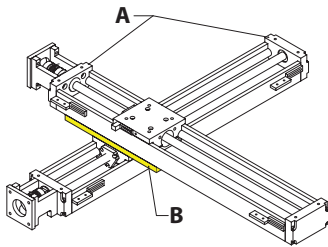

A. (2) LAVL2-60Txxxx  
B. (1) LAVLACC-004

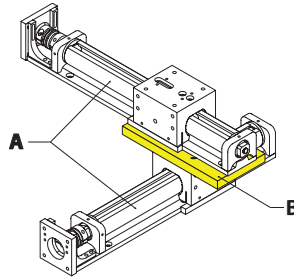

A. (2) LACP2-16Txxxx  
B. (1) LACPACC-004

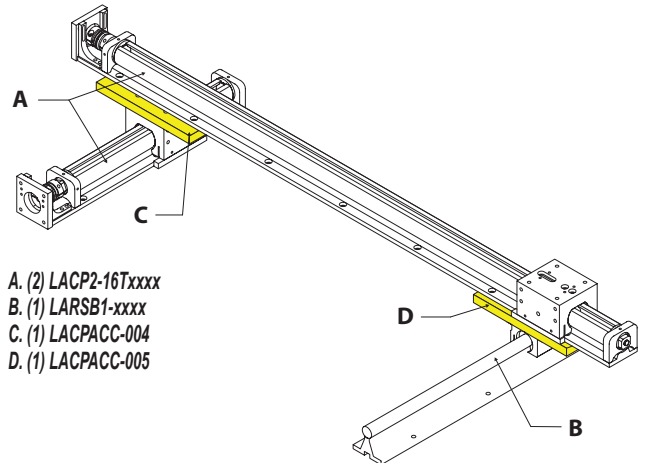

A. (2) LACP2-16Txxxx  
B. (1) LARSB1-xxxx  
C. (1) LACPACC-004  
D. (1) LACPACC-005

##### X-Z Axis Configuration

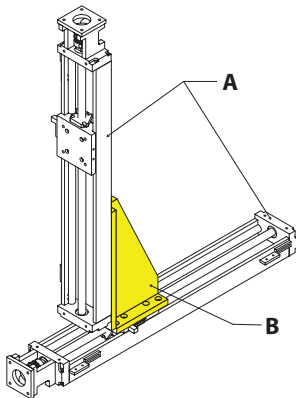

A. (2) LAVL2-60Txxxx  
B. (1) LAVLACC-005

##### X-Y-Z Axis Configuration

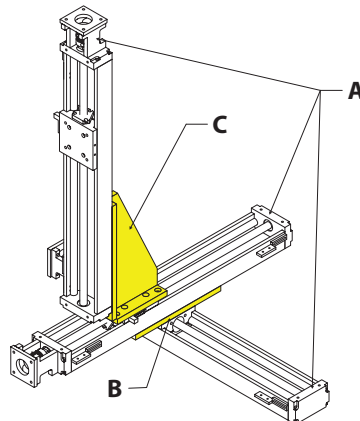

A. (3) LAVL2-60Txxxx  
B. (1) LAVLACC-004  
C. (1) LAVLACC-005

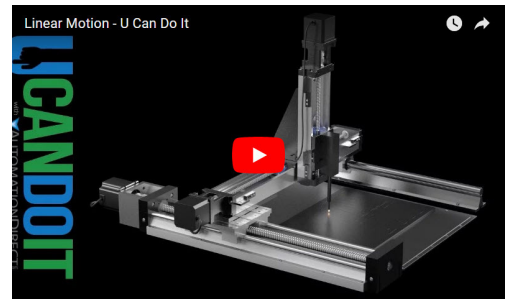

Click on the above video link for a short visual example of how our products can be used.