

Roxburgh TOR Series Toroids

Drive Rated Toroids for Single and Three-phase Applications

The Roxburgh TOR Series ferrite core chokes are specifically designed to aid in the reduction of common mode noise for AC and DC devices. Provides acceptable performance where excessive EMI and RF noise is evident on load side of the drive or device.

Features

- Delivers good performance common mode interference
- Dielectric breakdown voltage strength 2kV DC
- Epoxy coating thickness 0.25 mm

Applications

- AC and DC drives
- General purpose mains filter and pulse applications

Standards and Certifications



Single-phase use

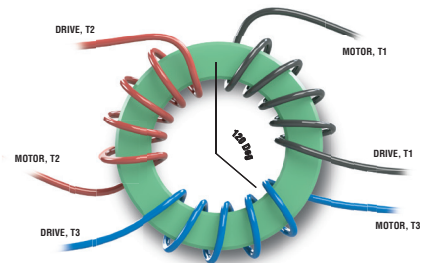

Three-phase use*

***NOTE:** When all three phases are wrapped onto a single toroid, space the wires at 120 degrees apart. Start each phase wire in the same direction wrapping from top surface and completing the wrap on the bottom surface; whether wrapping once or multiple times.

Toroid Filters			
Part Number	Price	Description	Weight kg (lb)
TOR221		Toroid: for all AC drives	0.236 (0.52)
TOR254		Toroid: for all AC drives	0.327 (0.7)

Toroid common mode chokes (ferrite cores) are normally installed on the output of an AC/DC drive to help reduce harmful EMI interference from affecting other equipment. The toroid cores should be mounted as close to the drive as possible. Do not run ground wire through the toroid. Do not allow the toroid core to touch a grounding point such as an unpainted backplane. This can cause EMI to propagate onto the ground plane. Wrap the motor wiring

through the toroid at least four times as shown above for both single and three-phase applications.

For very large wire gauge applications, wrapping a wire around multiple cores is equivalent to wrapping a wire multiple times around one core. If possible try to attain at least one wrap from each phase around the stack of cores.

Dimensions mm [inches]

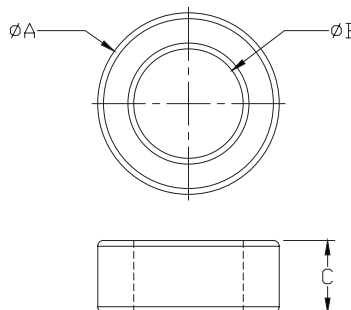

PART NUMBER	øA	øB	C
TOR221	63.0 [2.48]	38.0 [1.50]	25.0 [0.98]
TOR254	102.0 [4.01]	65.8 [2.59]	15.0 [0.59]