



EchoPod/EchoTouch® Reflective Technology™ Ultrasonic Liquid Level Sensors



Overview

The innovative EchoPod/EchoTouch Reflective Technology ultrasonic liquid level sensors replace other ultrasonic level sensors in condensation applications, as well as float, conductance and pressure sensors that fail due to contact with dirty, sticky and scaling media in small, medium and large capacity tanks. Applied in chemical, water and wastewater applications, these general purpose or intrinsically safe non-contact sensors are available with single and multi-function capabilities, including continuous level measurement, switching and control. The standard 4-20 mA output is easily monitored by a PLC or other controller. Models with four relays can be configured for level alarms and/or stand-alone level control such as automatic fill or empty functions using the embedded level controller. PC configuration of all models is simple with WebCal™ software, while the UG06, UG12 and US06 models also offer limited configuration via their pushbuttons and integral display.

What is Reflective Technology™?

Condensation is the most commonly encountered variable in liquid level applications. Condensation attenuates the acoustic signal of ultrasonic sensors that have a flat horizontal transducer face, weakening their signal strength and signal-to-noise ratio by up to 50%, and substantially reducing their measurement reliability. At the core of Reflective Technology™ is a simple fact: unlike flat horizontal surfaces, significant water droplets cannot adhere to smooth vertical surfaces. By orienting the internal ultrasonic transducer vertically, condensation runs off the transducer face and does not affect sensor performance. The unimpeded transmit and receive signals are redirected to and from the liquid off a 45° reflector, delivering reliable level measurement. Thanks gravity!



WebCal Software



WebCal



LI99-2001

WebCal PC software is a utility program that enables users to easily configure their EchoSonic II, EchoTouch and EchoPod level transmitters, switches, and controllers. Download your free copy of WebCal at www.flowline.com and connect □ sensor through our Fob USB adapter (LI99-2001). Develop your configuration using pre-programmed function menus as the tank graphic and set point fields automatically change to match your configuration. Then, input your level set point values and click the Write to Unit button. Your configuration will be downloaded into the sensor and verified in less than a second. Last, click the Wiring Diagram button to open a wiring schematic of your configuration in PDF format. Print the document, disconnect the sensor and wire it per the schematic. As new software or firmware becomes available, it can be downloaded and updated through WebCal.

Reflective Technology

Horizontal Transducer

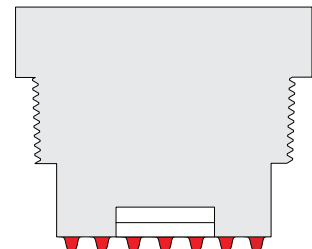

Signal Attenuation

Reflective Transducer

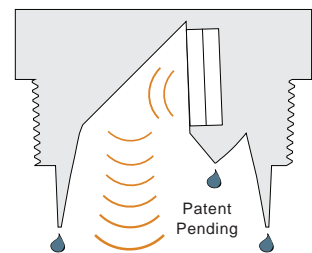

Reliable Measurement



EchoPod/EchoTouch® Reflective Technology™ Ultrasonic Liquid Level Sensors

| EchoPod/EchoTouch Reflective Technology Ultrasonic Liquid Level Sensors General Specifications | | | | | | | |
|--|--|----------------------------------|--|--|--|----------------------------------|--|
| Model | <i>UG01-0001-40</i> | <i>UG03-0001-40</i> | <i>UG06-0001-00</i> | <i>UG12-0001-00</i> | <i>US01-0001-00</i> | <i>US03-0001-00</i> | <i>US06-0001-00</i> |
| Price | | | | | | | |
| Type | EchoPod/EchoTouch Reflective Technology (works in condensing environments) | | | | | | |
| Classification | General purpose (non-hazardous) | | | | Intrinsically safe | | |
| Media | Liquids | | | | | | |
| Range | 1.5 in to 4.9 ft (3.8 cm to 1.5 m) | 4in to 9.8 ft (10.1 cm to 3m) | 8in to 19.6 ft (20cm to 6m) | 18in to 39.3 ft (45.7 cm to 12m) | 1.5 in to 4.9 ft (3.8 cm to 1.5 m) | 4in to 9.8 ft (10.1 cm to 3m) | 8in to 19.6 ft (20cm to 6m) |
| Output | 4-20 mA and (4) SPST relays | | | 4-20 mA (No Relays) | | | |
| Mounting | Vertical, top of tank, 2in NPT male | | | Vertical, top of tank, 3in NPT male | Vertical, top of tank, 2in NPT male | | |
| Electrical Termination | Integral 48in, 9-conductor, shielded cable | | Screwless terminals, 1/2in female NPT | | Integral 48in, 4-conductor, shielded cable | | Screwless terminals, 1/2in female NPT |
| Configuration | WebCal Software (free download) and LI99-2001 Fob USB Adapter (purchased separately) | | WebCal Software (free download) and LI99-2001 Fob USB Adapter (purchased separately) or Pushbutton / LCD | | WebCal Software (free download) and LI99-2001 Fob USB Adapter (purchased separately) | | WebCal Software (free download) and LI99-2001 Fob USB Adapter (purchased separately) or Pushbutton / LCD |
| Ambient Temperature | -31° to 140°F (-35° to 60°C) | | | | | | -40° to 176°F (-40° to 80°C) |
| Process Temperature | -40° to 176°F (-40° to 80°C) | | | | | | |
| Pressure | 30 PSI (2 bar) max. | | | | | | |

EchoPod® UG01 & UG03 Series Ultrasonic Liquid Level Sensors



Part No. UG01-0001-00 Shown

| UG01 & UG03 Technical Specifications | | |
|--------------------------------------|--|----------------------------------|
| Model | UG01-0001-40 | UG03-0001-40 |
| Price | | |
| Weight (lbs) | 1.5 | 1.5 |
| Range | 1.5 in to 4.9 ft (3.8 cm to 1.5 m) | 4in to 9.8 ft (10.1 cm to 3m) |
| Accuracy | 0.125 in (3mm) | ±0.2% of range |
| Resolution | 0.019 in (0.5 mm) | 0.039 in (1mm) |
| Sensing Dead Band* | 1.5 in (3.8 cm) | 4in (10.1 cm) |
| Beam Width | 2in (5cm) | |
| Configuration | WebCal® PC Windows® USB® 2.0 | |
| Memory | Non-volatile | |
| Supply Voltage | 14-28 VDC | |
| Max. Consumption | 0.5 W | |
| Loop Resistance | 500Ω @ 24VDC | |
| Signal Output | 4-20 mA, two-wire | |
| Signal Invert | 4-20 mA or 20-4 mA | |
| Signal Fail-Safe | 4mA, 20mA, 21mA, 22mA, hold last | |
| Contact Type | (4) SPST relays (N.O./N.C. selectable) | |
| Contact Rating | 60VA, 1A maximum | |
| Contact fail-safe | Open, closed, hold last | |
| Contact Hysteresis | Selectable | |
| Process Temperature | -40° to 176°F (-40° to 80°C) | |
| Temp. Compensation | Automatic | |
| Ambient Temperature | -31° to 140°F (-35° to 60°C) | |
| Pressure | 30 PSI (2 bar) | |
| Enclosure Rating | Type 6P (IP68) | |
| Enclosure Material | Polypropylene (PP) | |
| Transducer Type | Reflective | |
| Transducer Material | Polyvinylidene flouride (PVDF) | |
| Cable Jacket Material | Polyurethane (PUR) | |
| Cable Type | 9-conductor, shielded | |
| Cable Length | 48in (1.2 m) | |
| Process Mount | 2in Male NPT | |
| Classification | General purpose | |
| Approval | CSA certified to UL 61010-1 | |
| Compliance | CSA, CE | |

Overview

The EchoPod UG01 and UG03 general-purpose reflective ultrasonic multi-function level transmitters provide continuous level measurement up to 9.8' (3m) with a 4-20 mA analog signal output and four relays, and are configured via WebCal software. The non-contact liquid level sensor features Flowline's proprietary Reflective Technology™ that delivers reliable level measurement in condensing environments. Each output relay can be configured for alarm, automatic fill or empty functions. Select this sensor for small tanks with non-foaming and mildly vaporous media such as chemicals, water, wastewater and oil. Typical applications include day tank, IBC or drum, cooling tower, skid or machine, process tank and waste sumps.

Features

- 1.5m (4.9') and 3m (9.8') measurement ranges
- Fail-safe diagnostics with selectable relay and signal outputs
- Narrow 2" (5cm) beam width for applications with limited space
- Corrosion resistant PVDF transducer and compact PP enclosure
- Short 1.5" (3.8cm) dead band maximizes tank filling capacity
- Automatic temperature compensation from -40° to 176°F (-40° to 80°C)
- Configuration via WebCal software
- Four programmable relays with embedded level control logic
 - 1 pump or valve with 3 alarms
 - 2 pumps lead-lag with 2 alarms
 - 2 pumps duplexing with 2 alarms
 - 4 independent switch point alarms
- Made in the USA

Agency Approvals

- CSA, CE



Dimensions

inches [mm]

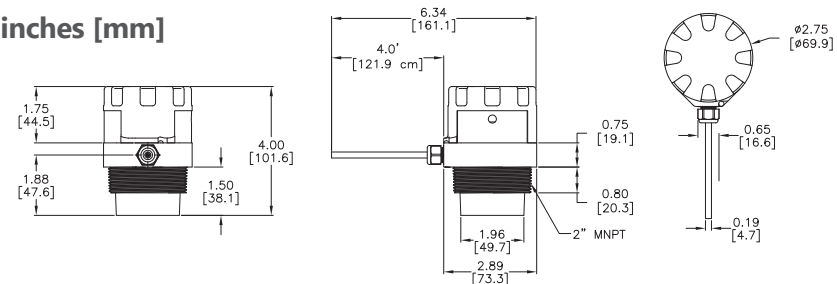

See our website [www.flowline.com](#) for complete Engineering drawings.

Configuration

The settings for the the UG01 & UG03 are configured with free WebCal software (downloadable from AutomationDirect Web site), and an LI99-2001 Fob USB adapter (purchased separately).



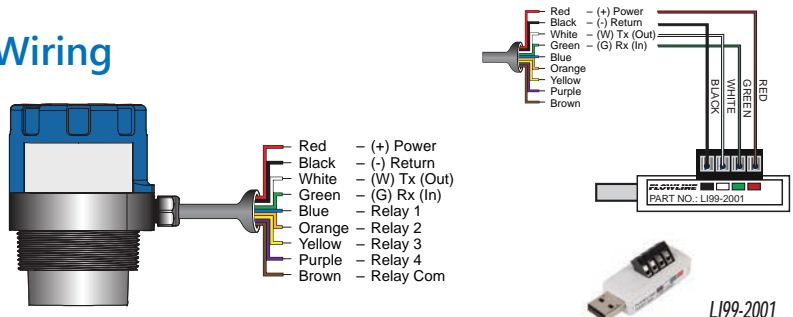











Wiring



* Dead band is the minimum distance the sensor must be mounted above the max liquid level.

See the end of the Ultrasonic Level Sensor Section for further details and Accessories

Ultrasonic Liquid Level Sensor Accessories

| Ultrasonic Liquid Level Sensor Accessories | | | | | |
|--|---|--|----------|--------|-------|
| Part No. | Item Photo | Description | Quantity | Weight | Price |
| LI40-1001 |  | Flowline PodView general purpose digital indicator, displays tank level or volume and sensor relay status, 6-digit LCD display with four relay status indicators, 3-button user interface, polycarbonate panel mount enclosure with NEMA 4 (IP65) faceplate, 6-foot (1.8-meter) 22AWG 4-conductor cable, for use with Flowline EchoPod DL, DS and DX series ultrasonic level sensor with firmware V50.0 or later | 1 | 0.6 | |
| LM50-1001 |  | Flowline side mount bracket, 2 inch NPT female threads, polypropylene (PP), for use with Flowline DL34, LU23, LU28, LU29, LU74, LU78, LU81, LU83, LU84, UG01, UG03, UG06, US01, US03 and US06 series ultrasonic level sensors | 1 | 0.4 | |
| LM50-1001-1 |  | Flowline side mount bracket, 2 inch NPT female threads, polypropylene (PP), and 2 inch NPT male x 1 inch NPT female reducer bushing (PVC), for use with Flowline DL14, DL24, DS14, DL10, DX10, LU27, LU77 and LU80 series ultrasonic level sensors | 1 | 0.6 | |
| LM52-1400 |  | Flowline reducer bushing, 2 inch NPT male x 1 inch NPT female threads, PVC, for use with Flowline DL14, DL24, DS14, DL10, DX10, LU27, LU77 and LU80 series ultrasonic level sensors | 1 | 0.2 | |
| LM52-2400 |  | Flowline reducer bushing, 3 inch NPT male x 2 inch NPT female threads, PVC, for use with Flowline DL34, LU23, LU28, LU29, LU74, LU78, LU81, LU83, LU84, UG01, UG03, UG06, US01, US03 and US06 series ultrasonic level sensors | 1 | 0.6 | |
| LM52-3800 |  | Flowline reducer bushing, PVC, 4in male NPT to 2in female NPT. For use with Flowline DL34, LU23, LU28, LU29, LU74, LU78, LU81, LU83, LU84, UG01, UG03, UG06, US01, US03 and US06 series ultrasonic level sensors | 1 | 2.0 | |
| LM52-1890 |  | Flowline low-profile bulkhead fitting, 1 inch NPT female x slip socket, with mounting nut, PVC, for use with Flowline DL14, DL24, DS14, DL10, DX10, LU27, LU77 and LU80 series ultrasonic level sensors | 1 | 0.5 | |
| LM52-2890 |  | Flowline low-profile bulkhead fitting, 2 inch NPT female x slip socket, with mounting nut, PVC, for use with Flowline DL34, LU23, LU28, LU29, LU74, LU78, LU81, LU83, LU84, UG01, UG03, UG06, US01, US03 and US06 series ultrasonic level sensors | 1 | 1.2 | |
| LM52-3890 |  | Flowline low-profile bulkhead fitting, PVC, 3in female NPT to slip socket. For use with Flowline UG12 series ultrasonic level sensors. Mounting hardware included. | 1 | 2.1 | |
| LM52-1850 |  | Flowline mounting flange, 1 inch NPT female threads, CPVC, for use with Flowline DL14, DL24, DS14, DL10, DX10, LU27, LU77 and LU80 series ultrasonic level sensors | 1 | 0.5 | |
| LM52-2850 |  | Flowline mounting flange, 2 inch NPT female threads, CPVC, for use with Flowline DL34, LU23, LU28, LU29, LU74, LU78, LU81, LU83, LU84, UG01, UG03, UG06, US01, US03 and US06 series ultrasonic level sensors | 1 | 1.0 | |
| LM52-3850 |  | Flowline mounting flange, CPVC, 3in female NPT. For use with Flowline UG12 series ultrasonic level sensors. | 1 | 1.9 | |
| 204038 |  | Replacement mounting gasket, for use with Flowline DL14, DL10, DX10 and DS14 series ultrasonic level sensors | 1 | 0.1 | |
| 200128 |  | Replacement mounting gasket, for use with Flowline DL24, LU27, LU77 and LU80 series ultrasonic level sensors | 1 | 0.1 | |
| 200129 |  | Replacement mounting gasket, for use with Flowline DL34, LU23, LU28, LU29, LU74, LU78, LU81, LU83 and LU84 series ultrasonic level sensors | 1 | 0.1 | |

When installing the 1" NPT level sensors care should be used to mechanically isolate the sensor housing from the tank. This can easily be done by using any of the Flowline mounting accessories which are designed to provide the isolation needed.

Ultrasonic Liquid Level Sensor Accessories

Dimensions

inches [mm]

LM50-1001

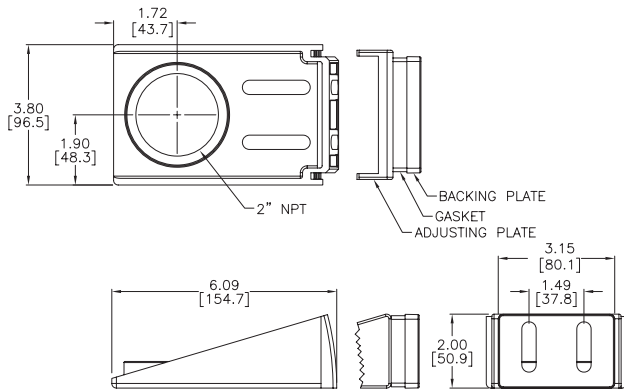

LM50-1001-1

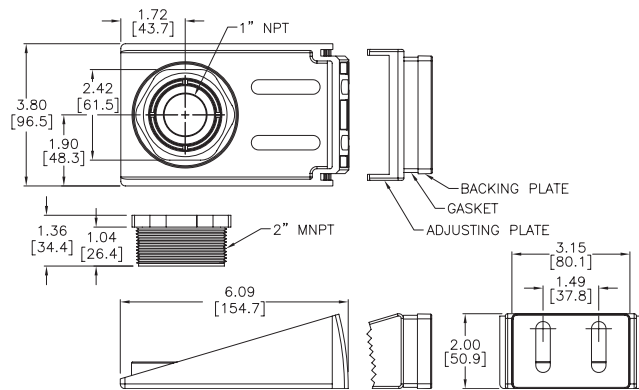

LM52-1400

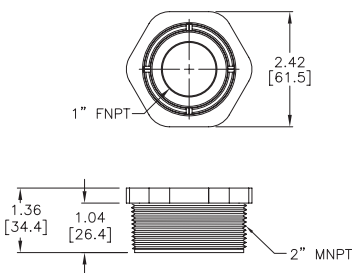

LM52-2400

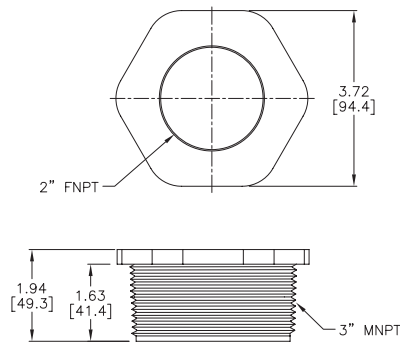

LM52-3800

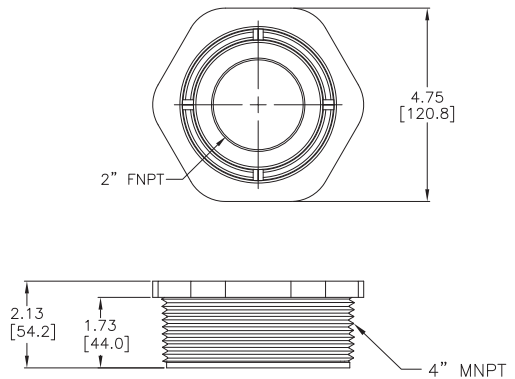

LM52-1890

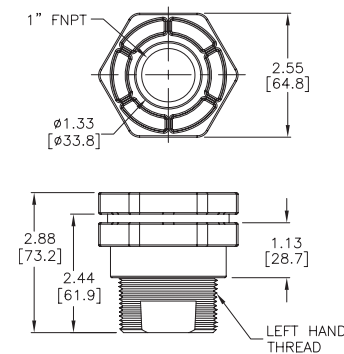

LM52-2890

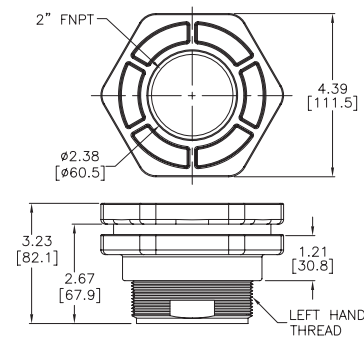

LM52-3890

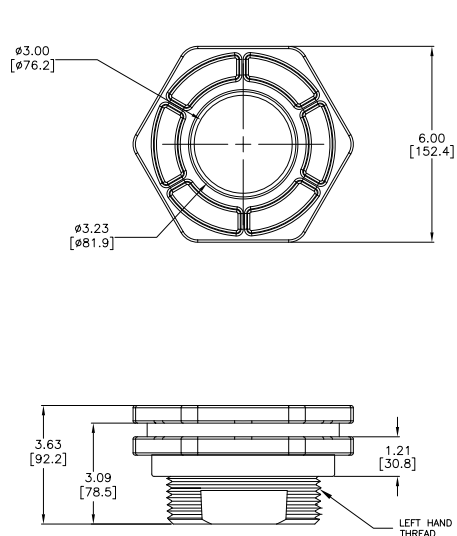

See our website [www.flowline.com](#) for complete Engineering drawings.

Ultrasonic Liquid Level Sensor Accessories

Dimensions

inches [mm]

LM52-1850

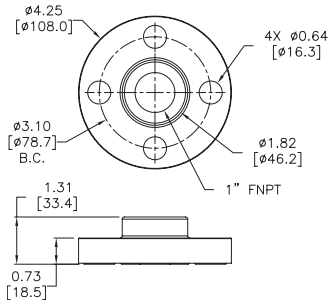

LM52-2850

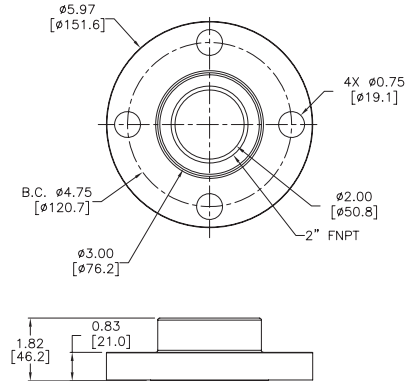

LM52-3850

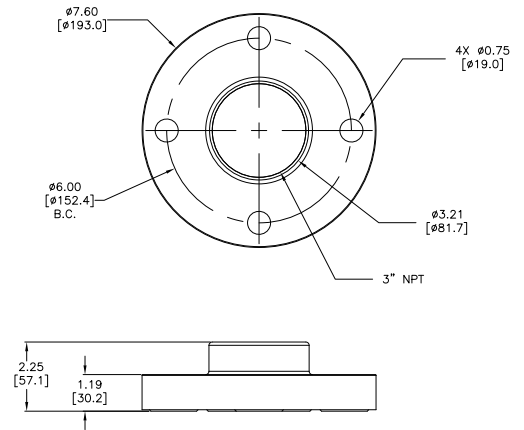

See our website [_____](#) for complete Engineering drawings.

WebCal Ultrasonic Level Sensor Software and USB Fob Adapter

Overview



WebCal PC software is a utility program that allows users to easily configure their EchoPod, EchoTouch and EchoSonic II level transmitters, switches, and controllers. Download your free copy

sensor through the Fob USB adapter (LI99-2001). Develop your configuration using pre-programmed function menus as the tank graphic and set point fields automatically change to match your configuration. Then, input your level set point values and click the Write to Unit button. Your configuration will be downloaded into the sensor and verified in less than a second. Last, click the Wiring Diagram button to open a wiring schematic of your configuration in PDF format. Print the document, disconnect the sensor and wire it per the schematic. It's that simple.

Configuration files can be named, saved, emailed, printed, opened and used again under revision control. The advanced feature page enables you to change the measurement signal, output filtering and invert relay states from N.O. to N.C. As new software or firmware becomes available, they can be downloaded and updated through WebCal.

Features

- 169 configurations with pull-down menu selections
- Graphical interface lets you visualize your configuration
- Applicable level set point fields appear automatically
- Installs and tests configuration in less than a second
- Available PDF wiring diagram for each configuration
- Technical help menu with FAQs, tips and glossary
- Rapidly program sensors to the same configuration
- Save configuration files for future use or reference
- Print wiring diagrams and configuration text files
- Email configuration files to other remote users
- Made in the USA
- Please check for the most recent system requirements.

| WebCal Ultrasonic Level Sensor Software and USB Adapter | | | | | |
|---|---|---|----------|--------------|-------|
| Part No. | Item Photo | Description | Quantity | Weight (lbs) | Price |
| LI99-2001 |  | Flowline Fob USB adapter, required for use with WebCal software to configure Flowline EchoPod, EchoTouch and EchoSonic II ultrasonic level sensors. | 1 | 0.1 | |
| WEBCAL |  | Configuration software CD for Flowline EchoPod, EchoTouch and EchoSonic II ultrasonic level sensors (also available as a free download from the AutomationDirect Web site). Requires an LI99-2001 Fob USB adapter (purchased separately). | 1 | 0.1 | |

EchoPod Configuration

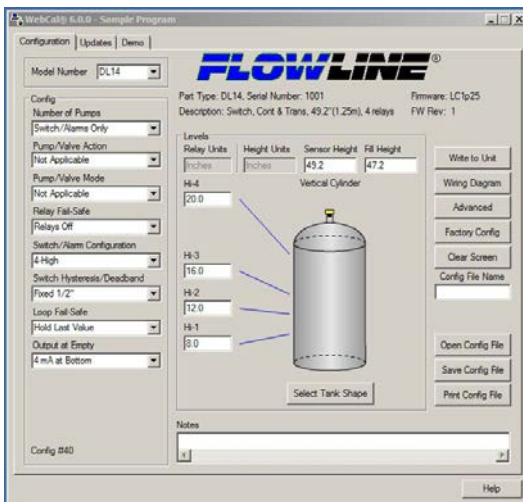

EchoSonic II Configuration

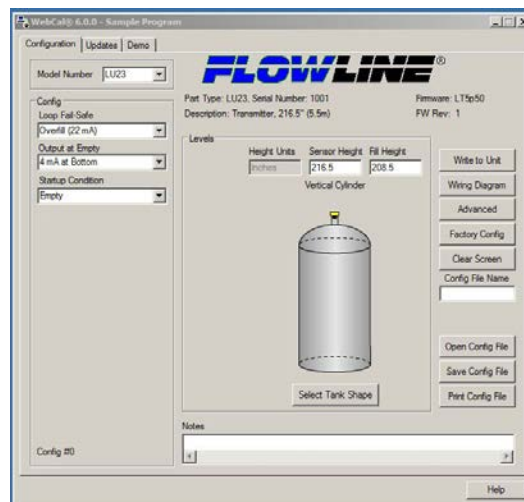

Click on the thumbnail or go to <https://VID-LE-0004> for Part 1 of our How To video on the use of the Flowline Ultrasonic Level Sensors



Click on the thumbnail or go to <https://VID-LE-0005> for Part 2 of our How To video on the use of the Flowline Ultrasonic Level Sensors