

Universal Signal Conditioners



The Universal Signal Conditioners from AutomationDirect are extremely versatile providing the flexibility to convert, transmit, scale and isolate signals from a wide variety of process sensors and controller I/O. With models 884114 and 884116, scalable input signal types supported include mA, VDC, thermocouple with internal cold junction compensation, 2-, 3-, 4-wire RTDs, linear resistance or potentiometer signals. Numerous selectable input ranges and two point field scalability will handle hundreds of applications. Outputs include mA, VDC; two individually programmable relays on the 884116 are used for alarming and control functions. The isolated universal supply voltage input eliminates the need for separate transformers or power supplies. Isolation is also provided between input and output.

The signal conditioners are easily configured with the 884501 menu-structured LCD programming/display module (a computer running special calibration software is not required and there are no confusing DIP switches or jumpers to set). Automatic scrolling Help text identifies each menu item. The detachable programming/display module can store and transfer configuration parameters from one signal conditioner to another, minimizing set-up time in multiple unit applications. Programming is available in seven different languages and the programming/display module can be password protected to prevent unauthorized changes to the configuration. When not used for configuration, the programming/display module can remain on the signal conditioner to display the input signal value and engineering units, output signal, and relay status (if equipped). A process simulation function allows manual manipulation of the input signal to control the output signal for trouble-shooting and checkout.

Universal Signal Conditioners

Features

- Flexibility to accept mA, VDC, thermocouple, RTD, linear resistance or potentiometer signal types
- Selectable input ranges and two point field scalability to handle hundreds of applications
- Direct and reverse acting mA and VDC analog output signal. The 884116 also includes two programmable SPST relay outputs.
- Universal supply voltage, 21.6 to 253 VAC or 19.2 to 300 VDC, polarity insensitive
- 3-way isolation between input, output, and power
- Auxiliary power supply output for 2-wire transmitters and 3-wire potentiometers
- Easy-to-use detachable LCD programming/display module 884501 (Sold separately and required for programming)
- Transfer configuration settings from one signal conditioner to another
- LEDs indicate operation and relay status (884116) when display module is not installed
- Integral 35mm DIN rail mounting adapter
- Removable screw terminal blocks are keyed to ensure correct installation
- UL508 listed, CE marked
- 5 year warranty

Universal Signal Conditioners		
Part No.	Description	Price
884114	Signal conditioner and isolator, single input • Accepts milliamps, volts, RTD, thermocouple or potentiometer • Single analog output supports 16 selectable signal ranges • Plastic slim-line housing • Detachable 884501 programming/display module (purchased separately) is required for unit configuration; module may remain affixed for operational display of input and output values	
884116	Signal conditioner and isolator, single input • Accepts milliamps, volts, RTD, thermocouple or potentiometer • Single analog output supports 16 selectable signal ranges • Two programmable Form A relay outputs • Plastic slim-line housing • Detachable 884501 programming/display module (purchased separately) is required for unit configuration; module may remain affixed for operational display of input and output values	
884501	Programming/display module, detachable, use with 884114 and 884116.	

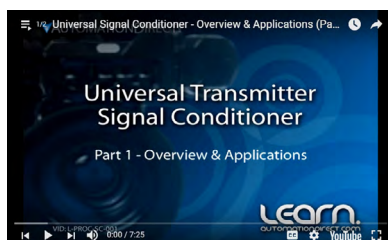

Click on the above thumbnail or go to <https://www.lamonde.com> -VID-PS-0004 for an overview and applications video on the Universal Signal Conditioners

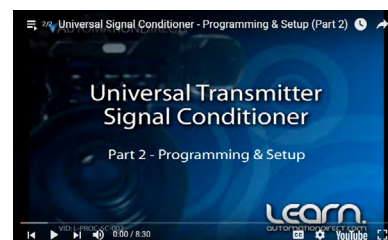

Click on the above thumbnail or go to <https://www.lamonde.com> -VID-PS-0005 for a programming and setup video on the Universal Signal Conditioners

Universal Signal Conditioners

Universal Signal Conditioners 884114/884116 Specifications (with or without 884501)		
General Specifications		
Temperature Range	-20°C to +60°C [-4°F to 140°F]	
Power	AC Power	21.6 to 253 VAC, 50/60 Hz
	DC Power	19.2 to 300 VDC
Consumption	≤ 2.5W	
Fuse	400 mA slow blow / 250 VAC (Not user replaceable)	
Auxiliary Power Supply Output	16-25 VDC, 20 mA max (Terminal 43 and 44)	
Isolation Voltage, Test/Operation	2.3 kVAC/250 VAC	
Configuration Interface	Programming/display module, 884501	
Signal/noise Ratio	Min. 60 dB (0 to 100 kHz)	
Response Time (0 to 90%, 100 to 10%)	Temperature input	≤ 1 sec
	mA / V input	≤ 400 ms
Calibration Temperature	20 to 28°C (68 to 82.4°F)	
Accuracy	The greater of the general and basic values (See Accuracy Table 1)	
Shock	EN61010-1	
Vibration	IEC 60068-2-6, IEC 60068-2-64	
EMC Immunity	≤ ±0.5% of span	
Extended EMC Immunity: NAMUR NE 21, A criterion, burst	≤ ±0.1% of span	
Environmental Conditions	Operating and Storage Temperature	-20 to +60°C [-4 to 140°F]
	Operating and Storage Humidity	95% relative humidity (non-condensing)
Approvals	CE, UL (#E314521, UL 508), EMC 2004/108/EC (EN 61326-1) LVD 2006/95/EC (EN61010-1) RoHS	
Construction	IP 50 enclosure, IP 20 terminals Touch Safe, case body is black high impact plastic. Pollution degree 1.	
Connections	Wire strip length	7.5mm [0.3 in]
	Wire gauge	26 - 14 AWG standard wire
	Torque	0.5 N-m [4.5 inch-lbs]
Weight	884114	145g [5.1 oz], 160 g [5.6 oz]
	884116	170g [5.9 oz], 185 g [6.5 oz]
	884501	15g [0.5 oz]
Dimensions	109 x 23.5 x 100mm [4.3 x .93 x 3.93 in], 109 x 23.5 x 116mm [4.3 x .93 x 4.6 in] with programming module	

Accuracy Table 1		
General Values		
Input Type	Absolute Accuracy	Temperature Coefficient
All	≤ ± 0.1% of span	≤ ± 0.01% of span/°C [0.01% of span/°F]
Basic Values		
Input Type	Basic Accuracy	Temperature Coefficient
mA	≤ ± 4 μA	≤ ± 0.4 μA/°C [±0.22μA/°F]
Volt	≤ ± 20 μV	≤ ± 2 μV/°C [±1.1μV/°F]
Pt100	≤ ± 0.2°C [±0.36°F]	≤ ± 0.01°C/°C [±.01°F/°F]
Linear resistance	≤ ± 0.1 Ω	≤ ± 0.01 Ω/°C [±.0056Ω/°F]
Potentiometer	≤ ± 0.1 Ω	≤ ± 0.01 Ω/°C [±.0056Ω/°F]
TC Type: E, J, K, L, N, T, U	≤ ± 1°C [±1.8°F]	≤ ± 0.05°C/°C [±.05°F/°F]
TC Type: B, R, S, W3, W5, LR	≤ ± 2°C [3.6°F]	≤ ± 0.2°C/°C [±0.2°F/°F]

Universal Signal Conditioners

Inputs			
Current Input			
Programmable Ranges	0 to 20 and 4 to 20 mA DC		
Measurement Range	-1 to 25 mA		
Input Resistance	Nom. 70 Ω		
Sensor Error Detection	4 to 20 loop break, $\leq 3.6\text{mA}$; $\geq 21\text{mA}$		
Voltage Input			
Programmable Ranges	0 to 1, 0.2 to 1, 0 to 5, 1 to 5, 0 to 10, and 2 to 10 VDC		
Measurement Range	-20 mV to 12 VDC		
Input Resistance	Nom. 10 M Ω		
Thermocouple Inputs			
Thermocouple Type	B, E, J, K, L, N, R, S, T, U, W3, W5, and LR		
Cold Junction Compensation	Via internally mounted sensor $< \pm 2.0^\circ\text{C}$ [$< \pm 3.6^\circ\text{F}$]		
Sensor Error Detection	Sensor break, $>750\text{k}\Omega/(1.25\text{V})$		
Sensor Error Current	When detecting 2 μA , otherwise 0 μA		
Type	Min. value	Max. value	Standard
B	+400°C [+752°F]	+1820°C [+3308°F]	IEC 60584-1
E	-100°C [-148°F]	+1000°C [+1832°F]	IEC 60584-1
J	-100°C [-148°F]	+1200°C [+2192°F]	IEC 60584-1
K	-180°C [-292°F]	+1372°C [+2502°F]	IEC 60584-1
L	-200°C [-328°F]	+900°C [+1652°F]	DIN 43710
N	-180°C [-292°F]	+1300°C [+2372°F]	IEC 60584-1
R	-50°C [-58°F]	+1760°C [+3200°F]	IEC 60584-1
S	-50°C [-58°F]	+1760°C [+3200°F]	IEC 60584-1
T	-200°C [-328°F]	+400°C [+752°F]	IEC 60584-1
U	-200°C [-328°F]	+600°C [+1112°F]	DIN 43710
W3	0°C [+32°F]	+2300°C [+4172°F]	ASTM E988-90
W5	0°C [+32°F]	+2300°C [+4172°F]	ASTM E988-90
LR	-200°C [-328°F]	+800°C [+1472°F]	GOST 3044-84
RTD, Linear Resistance, Potentiometer Inputs			
RTD Types	Pt10, Pt20, Pt50, Pt100, Pt200, Pt250, Pt300, Pt400, Pt500, Pt1000, Ni50, Ni100, Ni120, and Ni1000		
Cable Resistance per Wire	RTD, 50 Ω max		
Sensor Current	RTD, Nom. 0.2 mA		
Sensor Error Detection	Sensor break $>15\text{k}\Omega$ Sensor short $<15\text{ Ohm}$ (N/A for Pt10, Pt20, Pt50)		
Input type	Min. value	Max. value	Standard
Pt100	-200°C [-328°F]	+850°C [+1562°F]	IEC60751
Ni100	-60°C [-76°F]	+250°C [+482°F]	DIN 43760
Linear Resistance	0 Ω	10k Ω	-
Potentiometer	10 Ω	100k Ω	-

Universal Signal Conditioners

Outputs	
Analog Output - Current	
Signal Range	0 to 20 mA
Programmable Signal Range	0 to 20, 4 to 20, 20 to 0, and 20 to 4 mA
Load Resistance	800 Ω max, 20mA, 16 VDC
Load Stability	0.01% of span, 100 Ω load
Output state on sensor error detection	0 / 3.5 mA / 23 mA / none selectable
Output Limitation	For 4 to 20 and 20 to 4 mA signals: 3.8 to 20.5 mA For 0 to 20 and 20 to 0 mA signals: 0 to 20.5 mA
Current Limit	≤ 28 mA
Analog Output - Voltage	
Signal Range (Span)	0 to 10 VDC
Programmable Signal Ranges	0 to 1, 0.2 to 1, 0 to 10, 0 to 5, 1 to 5, 2 to 10, 1 to 0, 1 to 0.2, 5 to 0, 5 to 1, 10 to 0, and 10 to 2 V
Load	500k Ω min
Relay outputs (884116 only)	
Relay Functions	Setpoint, Window, Sensor Error, Power and Off
Hysteresis	0.1 to 25% (1 to 2999 display counts)
On and Off Delay	0 to 3600 sec
Relay state on sensor error detection	Break / Make / Hold selectable
Relay contact ratings	250 Vrms max; 2 A AC or 1 A DC max; 500 VA max

Wiring Diagrams

Supply:

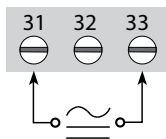

Inputs:

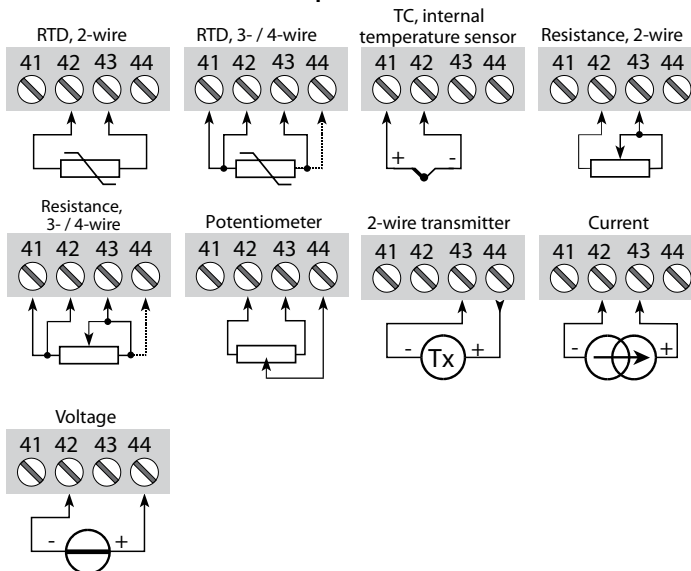

Outputs:

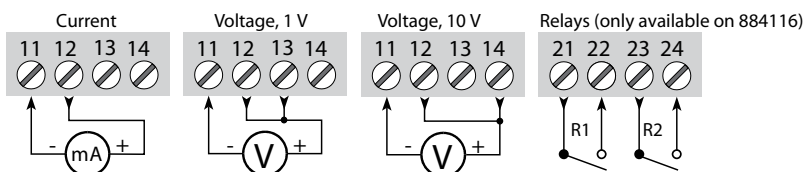

Universal Signal Conditioners

Dimensions 884114 and 884116

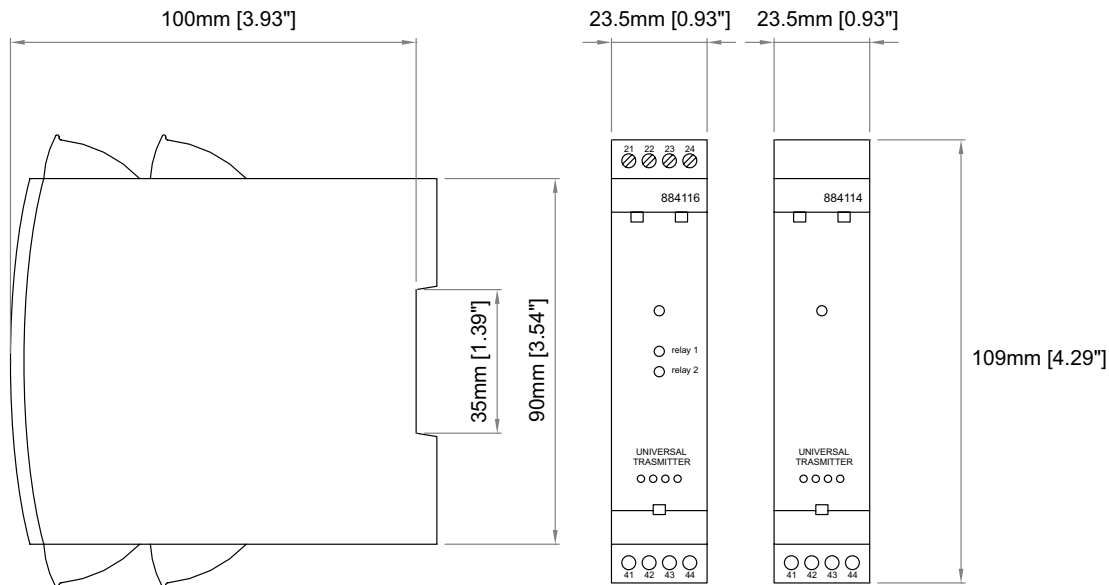

Programming/Display Module 884501

Application:

- The AutomationDirect 884501 module easily connects to the front of the Universal Signal Conditioners 884114 and 884116 and is used to enter or adjust the programming of the module.
- Can be moved from one module to another and download the configuration of the first transmitter to subsequent transmitters.
- Fixed display for visualization of process data and status.
- Required for programming modules 884114 and 884116.

Technical characteristics:

- LCD display with 4 lines; Line 1 (H = 5.57 mm, 0.22 in) shows input signal, line 2 (H = 3.33 mm, 0.13 in) shows units, line 3 (H = 3.33 mm, 0.13 in) shows analog output or user defined text and line 4 shows communication and relay status.
- Programming access can be blocked by assigning a password. The password is saved in the transmitter in order to ensure against unauthorized modifications to the configuration.
- Not capable of standalone or remote operation.



Mounting/Installation:

- Snap 884501 onto the front of the 884114 or 884116 signal conditioners

Selectable Engineering Units

°C	hp	kW	mA	pH
°F	hPa	kWh	mbar	rpm
%	Hz	l	mils	s
A	in	l/h	min	S
bar	in/h	l/min	mm	t
cm	in/min	l/s	mm/s	t/h
ft	in/s	m	mol	uA
ft/h	ips	m/h	MPa	uS
ft/min	K	m/min	mV	V
ft/s	kA	m/s	MW	W
g	kg	m/s ²	MWh	Wh
gal/h	kJ	m ³	N	yd
gal/min	kPa	m ³ /h	Ohm	
GW	kV	m ³ /min	Pa	

