

IronHorse® Aluminum Worm Gearboxes

Aluminum Model Overview



**IronHorse Aluminum Hollow Bore
Worm Gearbox**



**IronHorse Aluminum Worm Gearbox
Accessories**

Gearbox Overview

Gearboxes, also known as enclosed gear drives or speed reducers, are mechanical drive components that can control a load at a reduced fixed ratio of the motor speed. The output torque is also increased by the same ratio, while the horsepower remains the same (less efficiency losses.) For example, a 10:1 ratio gearbox outputs approximately the same motor output horsepower, motor speed divided by 10, and motor torque multiplied by 10.

Worm gearboxes contain a worm (gear type) on the input shaft, and a mating gear on the output shaft. Worm gearboxes also change the drive direction by 90°.

IronHorse worm gearboxes are manufactured in an ISO9001 certified plant by one of the leading gearbox manufacturers in the world today. Only the highest quality materials are tested, certified, and used in the manufacturing process. Strict adherence to and compliance with the toughest international and U.S. testing standards and manufacturing procedures assure you the highest quality products.

Aluminum gearboxes feature hollow-bore outputs (hollow all the way through from one side to the other). These gearboxes also utilize C-face mounting interfaces for trouble-free connections to C-face motors. We also offer optional single and double output shafts, output flanges, torque arms, and output covers.

Features

- 10:1 to 100:1 ratios
- Box sizes 30 to 75 mm
- Aluminum alloy housing for lightweight design
- Hardened worm shaft for increased durability
- Two bearings on input and output shafts
- NEMA motor input flanges
- All units filled with Mobil SHC634 synthetic oil
- No vent plug or breather needed; maintenance-free reducer
- Double lip oil seals prevent leakage
- Multiple mounting holes for all angle mounts
- Epoxy paint applied to inside and outside of reducer to protect against corrosion
- Hollow output bores with available plug-in output shafts
- Multiple mounting orientation options (see user manual for allowed mounting orientations)
- Single and Double Output Shaft material: S45C
- Single and Double Output Shaft Hardness: HBS220~260

Applications

- Use with electric motors for reducing output speed, increasing torque, changing drive direction, or running two loads from one motor.
- Use for conveyors, packaging machines, rotary tables, etc.

IronHorse[®] Aluminum Worm Gearboxes

Specifications

IronHorse Aluminum Worm Gearbox Specifications – 30, 40, 50, & 63 mm Frames																		
Part Number	Price	Nominal / Actual Ratio	Output RPM @ 1750 RPM Input	Nominal Motor HP ¹ @1800 rpm	NEMA Motor Frame	Output Type ²	Center Distance ³ (mm)	Overhung Load ⁴ (lb)	Output Shaft Thrust Load (lb)	Efficiency (%)	Approx Weight (lb)	Maximum Ratings @ 1750 RPM Input			Maximum Input Speed (rpm)	Maximum Backlash (arc-minute)		
												Mechanical ⁵						
												Input Power (hp)	Output Power (hp)	Output Torque (lb-in)				
WGA-30M-010-H1		10:1	175	0.5	56C	H	30	142	31	80	3	0.54	0.43	150	2,000	28.8		
WGA-30M-020-H1		20:1	88	0.25								0.30	0.22	150		28.2		
WGA-30M-030-H1		30:1	58	0.25								0.25	0.16	177		28.8		
WGA-30M-040-H1		40:1	44	0.2								0.19	0.10	150		28.2		
WGA-30M-060-H1		60:1	29	0.12								0.12	0.06	142		25.8		
WGA-40M-010-H1		10:1	175	1	56C	H	40	279	60	83	5	1.15	0.95	354	2,000	24.0		
WGA-40M-020-H1		20:1	88	0.5								0.61	0.48	345				
WGA-40M-030-H1		30:1	58	0.5								0.53	0.36	389				
WGA-40M-040-H1		40:1	44	0.33								0.39	0.25	363				
WGA-40M-060-H1		60:1	29	0.25								0.25	0.14	319				
WGA-40M-080-H1		80:1	22	0.12	0.19	0.10	283	21.6										
WGA-40M-100-H1		100:1	17.5	0.12	0.15	0.07	257											
WGA-50M-010-H1		10:1	175	2	56C	H	50	406	83	84	8	2.06	1.73	628	2,000	19.2		
WGA-50M-020-H1		20:1	88	1								1.13	0.88	646		17.4		
WGA-50M-030-H1		30:1	58	0.75								0.95	0.67	734		19.2		
WGA-50M-040-H1		40:1	44	0.75								0.70	0.46	664		17.4		
WGA-50M-060-H1		60:1	29	0.33								0.46	0.26	602		16.2		
WGA-50M-080-H1		80:1	22	0.33	0.38	0.19	566											
WGA-50M-100-H1		100:1	17.5	0.25	0.28	0.13	487											
WGA-63M-010-H1		10:1	175	3	56C	H	63	510	108	86	13	3.67	3.16	1141	2,000	17.4		
WGA-63M-010-H2		10:1	175	3								145TC	3.67	3.16			1141	
WGA-63M-020-H1		20:1	88	2								56C	2.04	1.63			1186	16.2
WGA-63M-020-H2		20:1	88	2								145TC	2.04	1.63			1186	
WGA-63M-030-H1		30:1	58	1.5								56C	H	63			736	156
WGA-63M-040-H1		40:1	44	1	807	172	70	1.26	0.88	1274	16.2							
WGA-63M-060-H1		60:1	29	0.75	928	197	59	0.86	0.51	1141	13.8							
WGA-63M-080-H1		80:1	22	0.5	1017	217	53	0.67	0.36	1071								
WGA-63M-100-H1		100:1	18	0.5	1088	234	48	0.57	0.27	1035								

1) Nominal Motor HP is the highest HP 1800 rpm motor to be used with the gearbox under conditions of 1.0 service factor. Gearbox input power capacity decreases as motor speed decreases and as service factor increases.

2) Output Type: H = Hollow Bore.

3) The Center Distance is the distance between the centerlines of the input and output shafts/bore; serves as the gearbox frame size.

4) Overhung Load ratings are for forces perpendicular to the output shaft and located at the shaft midpoint, such as from a gear, pulley, or sprocket with a belt or chain. Divide OHL ratings by the applicable OHL K factors shown separately in the Selection Factors tables. OHL ratings should also be divided by applicable service factors.

5) Maximum Mechanical Ratings are limits based on strength and durability of gearbox components; applicable when operating time is short and stopped time is greater than or equal to operating time. These ratings are applicable for 1.0 service factor loads, and may require modification depending upon characteristics of the applicable driven loads. Refer to the "Service Factors" table for more information.

IronHorse® Aluminum Worm Gearboxes

Specifications (continued)

IronHorse Aluminum Worm Gearbox Specifications – 75 mm Frames																
Part Number	Price	Nominal / Actual Ratio	Output RPM @ 1750 RPM Input	Nominal Motor HP ¹ @ 1800 rpm	NEMA Motor Frame	Output Type ²	Center Distance ³ (mm)	Overhung Load ⁴ (lb)	Output Shaft Thrust Load (lb)	Efficiency (%)	Approx Weight (lb)	Maximum Ratings @ 1750 RPM Input			Maximum Input Speed (rpm)	Maximum Backlash (arc-minute)
												Mechanical ⁵				
												Input Power (hp)	Output Power (hp)	Output Torque (lb-in)		
WGA-75M-010-H1		10:1	175	5	56C	H	75	604	128	86	19	5.44	4.68	1717	2,000	16.2
WGA-75M-010-H2		10:1	175	5	145TC			604	128	86		5.44	4.68	1717		
WGA-75M-010-H3		10:1	175	5	182/4TC			604	128	86		5.44	4.68	1717		
WGA-75M-020-H1		20:1	88	3	56C			759	161	79		3.14	2.48	1849		14.4
WGA-75M-020-H2		20:1	88	3	145TC			759	161	79		3.14	2.48	1849		
WGA-75M-030-H1		30:1	58	2	56C			873	185	72		2.48	1.79	2026		16.2
WGA-75M-040-H1		40:1	44	1.5				957	203	68		1.88	1.28	1947		14.4
WGA-75M-060-H1		60:1	29	1				1099	232	62		1.26	0.78	1770		12.6
WGA-75M-080-H1		80:1	22	0.75				1205	256	58		0.97	0.56	1672		
WGA-75M-100-H1		100:1	18	0.75				1289	276	52		0.80	0.42	1593		

1) Nominal Motor HP is the highest HP 1800 rpm motor to be used with the gearbox under conditions of 1.0 service factor. Gearbox input power capacity decreases as motor speed decreases and as service factor increases.

2) Output Type: H = Hollow Bore.

3) The Center Distance is the distance between the centerlines of the input and output shafts/bores; serves as the gearbox frame size.

4) Overhung Load ratings are for forces perpendicular to the output shaft and located at the shaft midpoint, such as from a gear, pulley, or sprocket with a belt or chain. Divide OHL ratings by the applicable OHL K factors shown separately in the Selection Factors tables. OHL ratings should also be divided by applicable service factors.

5) Maximum Mechanical Ratings are limits based on strength and durability of gearbox components; applicable when operating time is short and stopped time is greater than or equal to operating time. These ratings are applicable for 1.0 service factor loads, and may require modification depending upon characteristics of the applicable driven loads. Refer to the "Service Factors" table for more information.

Gearbox Selection Factors

Overhung Load K Factors for Various Drive Types	
Chain & Sprocket	1.00
Gear	1.25
V-belt	1.50
Flat Belt	2.50
Variable Pitch Belt	3.50

Divide gearbox OHL ratings by the applicable OHL K factors.

Service Factors for Selecting Gearboxes (when used with electric motors)				
Service Continuity (per day)	Load Characteristics			
	Uniform	Moderate Shock*	Heavy Shock*	Extreme Shock*
Occasional 1/2 hour	1.00	1.00	1.00	1.25
Less than 3 hours	1.00	1.00	1.25	1.50
3-10 hours	1.00	1.25	1.50	1.75
More than 10 hours	1.25	1.50	1.75	2.00

* Shock results from sudden increases in the torque demand of the load, such as: sudden stopping, restarting, and/or reversing; significantly heavy loads dropped onto a moving conveyor; impact loads such as punch press operations.

Depending upon the load characteristics, divide the gearbox HP, Overhung Load, and Maximum Mechanical Capacity ratings by the applicable service factor.

IronHorse[®] Aluminum Worm Gearboxes

Specifications (continued)

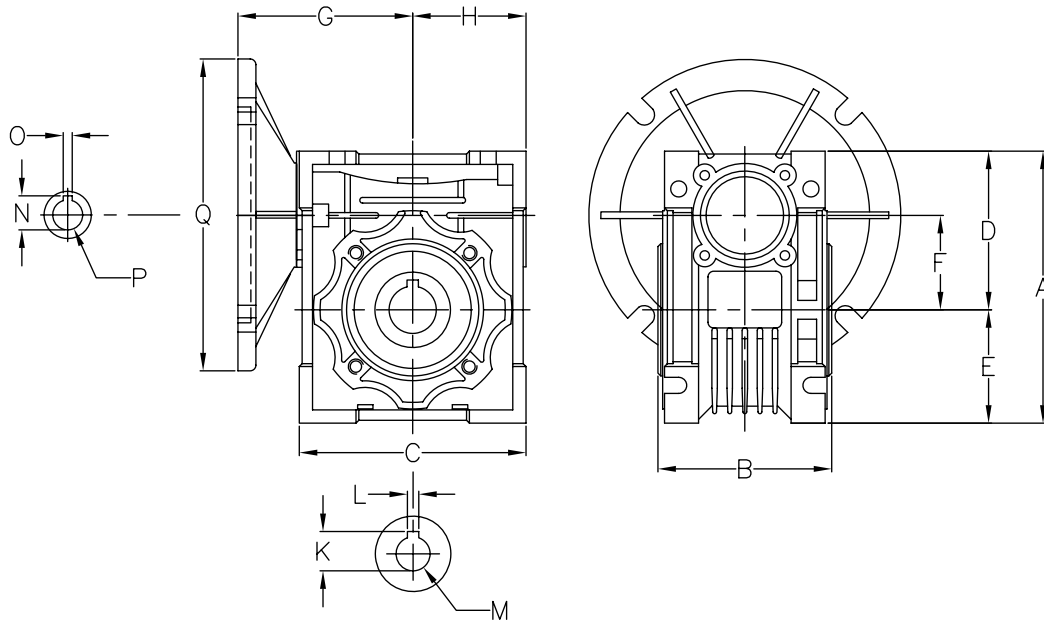





Dimensions (inches) – IronHorse Aluminum Worm Gearboxes																
Part Number	NEMA Motor Face	A	B	C	D	E	F	G	H	Output Bore			Input Shaft			ØQ
										K	L	ØM	N	O	ØP	
WGA-30M-xxx-H1	56C	3.82	2.48	3.15	2.24	1.57	1.18	3.19	1.57	0.720	0.187	0.625	0.73	0.19	0.625	6.50
WGA-40M-xxx-H1		4.78	3.07	3.94	2.81	1.97	1.57	3.18	1.97	0.840	0.187	0.750	0.71	0.19	0.625	6.50
WGA-50M-xxx-H1		5.67	3.62	4.72	3.31	2.36	1.97	3.58	2.36	1.110	0.250	1.000	0.71	0.19	0.625	6.50
WGA-63M-xxx-H1		6.87	4.42	5.69	4.00	2.87	2.48	4.06	2.84	1.250	0.250	1.125	0.71	0.19	0.625	6.50
WGA-63M-xxx-H2	145TC	6.87	4.42	5.69	4.00	2.87	2.48	4.06	2.84	1.250	0.250	1.125	0.97	0.19	0.875	6.50
WGA-75M-xxx-H1	56C	8.07	4.72	6.77	4.69	3.39	2.95	4.68	3.39	1.375	0.250	1.250	0.71	0.19	0.625	6.50
WGA-75M-xxx-H2	145TC	8.07	4.72	6.77	4.69	3.39	2.95	4.68	3.39	1.375	0.250	1.250	1.24	0.25	1.125	6.50
WGA-75M-xxx-H3	182/4TC	8.07	4.72	6.77	4.69	3.39	2.95	4.68	3.39	1.375	0.250	1.250	1.24	0.25	1.125	8.97

See our website: for complete engineering drawings.

IronHorse® Aluminum Worm Gearboxes

Accessories

IronHorse Aluminum Worm Gearbox Accessories			
Part Number	Price	Description	Typical Photo
WGA-30M-ACC1		Output flange, for aluminum WGA-30M series gearboxes. Includes (4) mounting screws.	
WGA-40M-ACC1		Output flange, for aluminum WGA-40M series gearboxes. Includes (4) mounting screws.	
WGA-50M-ACC1		Output flange, for aluminum WGA-50M series gearboxes. Includes (4) mounting screws.	
WGA-63M-ACC1		Output flange, for aluminum WGA-63M series gearboxes. Includes (8) mounting screws.	
WGA-75M-ACC1		Output flange, for aluminum WGA-75M series gearboxes. Includes (8) mounting screws.	
WGA-30M-ACC2		Torque arm, for aluminum WGA-30M series gearboxes. Includes (4) mounting screws.	
WGA-40M-ACC2		Torque arm, for aluminum WGA-40M series gearboxes. Includes (4) mounting screws.	
WGA-50M-ACC2		Torque arm, for aluminum WGA-50M series gearboxes. Includes (4) mounting screws.	
WGA-63M-ACC2		Torque arm, for aluminum WGA-63M series gearboxes. Includes (8) mounting screws.	
WGA-75M-ACC2		Torque arm, for aluminum WGA-75M series gearboxes. Includes (8) mounting screws.	
WGA-30M-ACC3		Single output shaft, Ø0.625 in, for aluminum WGA-30M series gearboxes. Includes (3) keys, (1) spacer, and (1) retaining ring.	
WGA-40M-ACC3		Single output shaft, Ø0.75 in, for aluminum WGA-40M series gearboxes. Includes (3) keys, (1) spacer, and (1) retaining ring.	
WGA-50M-ACC3		Single output shaft, Ø1.0 in, for aluminum WGA-50M series gearboxes. Includes (3) keys, (1) spacer, and (1) retaining ring.	
WGA-63M-ACC3		Single output shaft, Ø1.125 in, for aluminum WGA-63M series gearboxes. Includes (3) keys, (1) spacer, and (1) retaining ring.	
WGA-75M-ACC3		Single output shaft, Ø1.25 in, for aluminum WGA-75M series gearboxes. Includes (3) keys, (1) spacer, and (1) retaining ring.	
WGA-30M-ACC4		Double output shaft, Ø0.625 in, for aluminum WGA-30M series gearboxes. Includes (4) keys, (2) spacers, and (2) retaining rings.	
WGA-40M-ACC4		Double output shaft, Ø0.75 in, for aluminum WGA-40M series gearboxes. Includes (4) keys, (2) spacers, and (2) retaining rings.	
WGA-50M-ACC4		Double output shaft, Ø1.0 in, for aluminum WGA-50M series gearboxes. Includes (4) keys, (2) spacers, and (2) retaining rings.	
WGA-63M-ACC4		Double output shaft, Ø1.125 in, for aluminum WGA-63M series gearboxes. Includes (4) keys, (2) spacers, and (2) retaining rings.	
WGA-75M-ACC4		Double output shaft, Ø1.25 in, for aluminum WGA-75M series gearboxes. Includes (4) keys, (2) spacers, and (2) retaining rings.	
WGA-30M-ACC5		Output cover, for aluminum WGA-30M series gearboxes. Includes (4) mounting screws.	
WGA-40M-ACC5		Output cover, for aluminum WGA-40M series gearboxes. Includes (4) mounting screws.	
WGA-50M-ACC5		Output cover, for aluminum WGA-50M series gearboxes. Includes (4) mounting screws.	
WGA-63M-ACC5		Output cover, for aluminum WGA-63M series gearboxes. Includes (4) mounting screws.	
WGA-75M-ACC5		Output cover, for aluminum WGA-75M series gearboxes. Includes (4) mounting screws.	

IronHorse® Worm Gearboxes

Gearbox Selection

Gearbox Selection Steps

- 1) Determine the torque and speed required for the load.
- 2) Determine the overall speed ratio of motor speed to load speed.
- 3) Determine the gearbox ratio as well as any reduction outside the gearbox (pulleys, gears, etc.).
- 4) Determine the applicable service factor and overhung load K factor.
- 5) Determine the gearbox real output torque required, and select a gearbox with a higher Maximum Thermal output Torque rating (for WG cast-iron gearboxes; not applicable for WGA aluminum gearboxes).
- 6) Determine the gearbox design output torque required (torque with service factor applied), and select a gearbox with a higher Maximum Mechanical Output Torque rating. (Gearbox must also meet requirement #5.)
- 7) Determine the required sizes of pulleys, gears, etc., and determine the overhung load force. Select a gearbox with a higher Overhung Load rating. (Gearbox must also meet requirements #5 & #6.)
- 8) Confirm that the selected gearbox meets the applicable system requirements.
- 9) Select a compatible motor.

Gearbox Selection Example (Refer to the specifications tables for gearbox specifications, service factors, and K factors.)

A conveyor will run 10 hours/day with moderate shock loading. The conveyor will be driven by a V-belt and needs to be driven at approximately 20 rpm. The motor to be used will have a nominal speed of 1800 rpm (1725 rpm actual speed). The conveyor will require 2700 in-lb of torque.

- 1) Required **torque** = 2700 in-lb; required **speed** = 20 rpm.
- 2) Determine the **overall speed ratio** of motor speed to load speed:
Overall speed ratio = motor speed / load speed = 1725 / 20 = 86.25 [about 86:1]
- 3) Determine **pulley ratios** at available **gearbox ratios**:
 $\text{Gearbox ratio} = (\text{overall speed ratio}) / (\text{pulley ratio})$
 $\text{Pulley ratio} = (\text{overall speed ratio}) / (\text{gearbox ratio})$
For **5:1 gearbox**: pulley ratio = 86.25 / 5 = **17.25** [17.25" pulley ratio is prohibitively large]
For 10:1 gearbox: pulley ratio = 86.25 / 10 = 8.63
For 15:1 gearbox: pulley ratio = 86.25 / 15 = 5.75
For 20:1 gearbox: pulley ratio = 86.25 / 20 = 4.31
For 30:1 gearbox: pulley ratio = 86.25 / 30 = 2.88
For 40:1 gearbox: pulley ratio = 86.25 / 40 = 2.16
For 60:1 gearbox: pulley ratio = 86.25 / 60 = 1.44
 $\text{Pulley ratio} = (\text{conveyor pulley diameter}) / (\text{gearbox pulley diameter})$
- 4) Determine **service factor (SF)** and **overhung load factor (K)** from applicable tables:
SF = 1.25 due to moderate shock loading and 3-10 hours/day operation
K = 1.5 due to V-belt
- 5) Use specifications table to select gearbox with **Maximum Thermal* Torque rating > required real torque**:
Gearbox required real torque = (final torque) / (pulley ratio)
For 10:1 gearbox: (2700 in-lb) / 8.63 = 312.86 in-lb; use WG-175-x or larger
For 15:1 gearbox: (2700 in-lb) / 5.75 = 469.57 in-lb; use WG-175-x or larger
For 20:1 gearbox: (2700 in-lb) / 4.31 = 626.45 in-lb; use WG-206-x or larger
For 30:1 gearbox: (2700 in-lb) / 2.88 = 937.50 in-lb; use WG-325-x or WGA-63M*
For 40:1 gearbox: (2700 in-lb) / 2.16 = 1250.0 in-lb; use WG-325-x
For 60:1 gearbox: (2700 in-lb) / 1.44 = 1875.0 in-lb; use WG-325-x
*** Aluminum gearboxes do not have thermal ratings; use mechanical ratings.**
- 6) Use specifications table to select gearbox with **Maximum Mechanical Torque rating > required design torque**:
Gearbox required design torque = (real gearbox torque)(service factor)
For 10:1 gearbox: (312.86 in-lb)(1.25) = 391.08 in-lb; use WG-175-x or larger
For 15:1 gearbox: (469.57 in-lb)(1.25) = 586.96 in-lb; use WG-206-x or larger
For 20:1 gearbox: (626.45 in-lb)(1.25) = 808.06 in-lb; use WG-206-x or larger
For 30:1 gearbox: (937.50 in-lb)(1.25) = 1178.88 in-lb; use WG-325-x or WGA-63M or larger
For 40:1 gearbox: (1250.0 in-lb)(1.25) = 1562.50 in-lb; use WG-325-x
For 60:1 gearbox: (1875.0 in-lb)(1.25) = 2343.75 in-lb; use WG-325-x

(continued on next page)

IronHorse® Worm Gearboxes

Gearbox Selection Example (continued)

(Refer to the specifications tables for gearbox specifications, service factors, and K factors.)

[Load requirements: Conveyor to run 10 hours/day; moderate shock loading; driven by V-belt @ approx 20 rpm; requires 2700 in-lb of torque. Motor speed 1725 rpm (1800 rpm nominal).

7) Use the gearbox overhung load ratings from the specifications table to determine the minimum allowable pulley diameters.

Select gearbox with **Overhung Load rating > overhung load force:**

Gearbox required OHL rating = (gearbox real torque)(K)(SF)/(gearbox pulley diameter / 2)

Minimum gearbox pulley diameter = (T)(K)(SF)(2)/(OHL rating)

Conveyor pulley diameter = (gearbox pulley diameter)(pulley ratio)

For 10:1, WG-175-010-x gearbox:

Minimum gearbox pulley diameter = (312.86 in-lb)(1.5)(1.25)(2)/(650 lb) = 1.8" [use 2"]

Conveyor pulley diameter = (2")(8.63) = ~~17.26"~~ [17.26" pulley size is prohibitively large]

Determine pulley sizes and OHL for next larger gearbox ratio.

For 15:1, WG-206-015-x gearbox:

Minimum gearbox pulley diameter = (469.57 in-lb)(1.5)(1.25)(2)/(700 lb) = 2.5" [use 2.5"]

Conveyor pulley diameter = (2.5")(5.75) = 14.38" [use 14.4"]

Select **WG-206-015-x gearbox, 2.5" gearbox pulley, and 14.4" conveyor pulley.**

For 20:1, WG-206-020-x gearbox:

N/A – larger ratio of same frame size GB is same price, yet provides lower efficiency and power characteristics

For 30:1, WGA-63M-030-H1 gearbox:

Minimum gearbox pulley diameter = (937.50 in-lb)(1.5)(1.25)(2)/(736 lb) = 4.78" [use 5"]

Conveyor pulley diameter = (5")(2.88) = 14.40" [use 14.4"]

N/A – WGA-63M & WG-325 gearboxes costs more than WG-206

For 40:1, N/A – WG-325-xxx gearboxes cost more than WG-206 at any ratio

For 60:1, N/A – WG-325-xxx gearboxes cost more than WG-206 at any ratio

8) **Check results** against original speed and torque requirements:

a) Conveyor speed = (motor speed) / (gearbox ratio)(pulley ratio) = (1725 rpm) / (15)(14.4"/2.5") = 20 rpm

b) Maximum real torque available at conveyor = (gearbox thermal torque)(pulley ratio) = (673 in-lb)(14.4"/2.5") = 3876 in-lb

c) Maximum design torque available at conveyor = (gearbox mechanical torque)(pulley ratio) / (service factor)
= (1002 in-lb)(14.4"/2.5") / 1.25 = 4617 in-lb

The speed is correct as required, and both maximum torque values are greater than the 2700 in-lb required by the load.

9) **Select a motor** and check torque transmitted to the load:

From the gearbox spec tables, WG-206-015-x efficiency = 85%.

maximum thermal input power = 1.40 hp

maximum mechanical input power @ 1.0 SF = 2.09 hp

maximum mechanical input power @ 1.25 SF = (rated max mechanical input power) / (SF) = 2.09 hp / 1.25 = 1.67 hp

maximum allowable motor power = 1.40 hp; select nominal 1hp motor

Select **1hp motor**, and check for adequate torque at the load:

Torque = Power / Speed [conversion factor: (1hp) = (63,025 in-lb-rpm)]

Torque load = (63,025 in-lb-rpm / hp)(gearbox input hp)(gearbox efficiency) / (motor rpm / (gearbox ratio)(pulley ratio))
= (63,025)(1)(0.85) / (1725 / (15/1)(14.4/2.5)) = ~~2683 in-lb~~ [insufficient torque at load]

This torque value is less than the 2700 in-lb required by the load.

So, select and check the next larger nominal motor size, which is 1-1/2 hp.

Since the 206 frame size 15 ratio gearboxes do not meet the 1-1/2 hp thermal rating, choose the WG-237-015-x gearbox.

Select **1-1/2 hp motor** and **WG-237-015-x gearbox**, and check for adequate torque:

WG-237-015-x gearbox efficiency = 84%

maximum thermal input power = 1.55 hp

maximum mechanical input power @ 1.25 SF = 2.64 hp / 1.25 = 2.11 hp

maximum allowable motor power = 1.55 hp; select nominal 1-1/2 hp motor

gearbox ratio is still 15:1, and OHL rating is increased to 900 lb, so the previous pulley calculations [step 7] remain sufficient

[smaller pulleys can be calculated and selected for this gearbox, if desired]

Tload = (63,025 in-lb-rpm/hp) (1.5hp) (84%) / (1725 rpm / (15/1)(14.4/2.5)) = 3977 in-lb > 2700 in-lb; sufficient torque at load

Final gearbox and motor selection: 1-1/2 hp motor WG-237-015-x gearbox